

Veritas NetBackup[™] Commands

Windows

Release 6.5

Veritas NetBackup Commands

Copyright © 1998 - 2007 Symantec Corporation. All rights reserved.

NetBackup 6.5

Symantec, the Symantec logo, and NetBackup are trademarks or registered trademarks of Symantec Corporation or its affiliates in the U.S. and other countries. Other names may be trademarks of their respective owners.

Portions of this software are derived from the RSA Data Security, Inc. MD5 Message-Digest Algorithm. Copyright 1991-92, RSA Data Security, Inc. Created 1991. All rights reserved.

The product described in this document is distributed under licenses restricting its use, copying, distribution, and decompilation/reverse engineering. No part of this document may be reproduced in any form by any means without prior written authorization of Symantec Corporation and its licensors, if any.

THIS DOCUMENTATION IS PROVIDED "AS IS" AND ALL EXPRESS OR IMPLIED CONDITIONS, REPRESENTATIONS AND WARRANTIES, INCLUDING ANY IMPLIED WARRANTY OF MERCHANTABILITY, FITNESS FOR A PARTICULAR PURPOSE OR NON-INFRINGEMENT, ARE DISCLAIMED, EXCEPT TO THE EXTENT THAT SUCH DISCLAIMERS ARE HELD TO BE LEGALLY INVALID, SYMANTEC CORPORATION SHALL NOT BE LIABLE FOR INCIDENTAL OR CONSEQUENTIAL DAMAGES IN CONNECTION WITH THE FURNISHING, PERFORMANCE, OR USE OF THIS DOCUMENTATION. THE INFORMATION CONTAINED IN THIS DOCUMENTATION IS SUBJECT TO CHANGE WITHOUT NOTICE.

The Licensed Software and Documentation are deemed to be "commercial computer software" and "commercial computer software documentation" as defined in FAR Sections 12.212 and DFARS Section 227.7202.

Symantec Corporation
20330 Stevens Creek Blvd.
Cupertino, CA 95014
www.symantec.com

Printed in the United States of America.

Third-party legal notices

Third-party software may be recommended, distributed, embedded, or bundled with this Symantec product. Such third-party software is licensed separately by its copyright holder. All third-party copyrights associated with this product are listed in the accompanying release notes.

Oracle is a registered trademark of Oracle Corporation.

Licensing and registration

Veritas NetBackup is a licensed product. See the *NetBackup Installation Guide* for license installation instructions.

Technical support

For technical assistance, visit <http://entsupport.symantec.com> and select phone or email support. Use the Knowledge Base search feature to access resources such as TechNotes, product alerts, software downloads, hardware compatibility lists, and our customer email notification service.

Contents

Chapter 1	Introduction	
	Command usage conventions	9
	NetBackup command conventions	10
	NetBackup Media Manager command notes	11
Chapter 2	NetBackup commands	
	acsd	13
	add_media_server_on_clients	15
	backupdbtrace	16
	backuptrace	18
	bmrc	20
	bmconfig	23
	bmrepadm	28
	bmrbprep	31
	bmrs	34
	bmrsrtadm	37
	bparchive	38
	bpbackup	42
	bpbackupdb	48
	bpcatarc	52
	bpclist	53
	bpctres	56
	bpctrm	57
	bpcd	58
	bpchangeprimary	60
	bpclient	65
	bpclntcmd	69
	bpcompatd	71
	bpconfig	73
	bpdbjobs	83
	bpdbm	91
	bpdown	94
	bpduplicate	96
	bperror	104
	bpexpdate	114

bpfis	121
bpgetconfig	124
bpgetdebuglog	126
bpimage	127
bpimagelist	131
bpimedia	138
bpimport	149
bpinst	155
bpkeyfile	163
bpkeyutil	165
bplabel	167
bplist	170
bpmedia	176
bpmedialist	179
bpminlicense	190
bpnbat	193
bpnbaz	200
bpfficorr	211
bpplclients	213
bppldelete	220
bpplininclude	221
bpplininfo	226
bppllist	236
bpplsched	238
bpplschedrep	249
bpolicynew	256
bpps	261
bprecover	265
bprestore	271
bpschedule	281
bpschedulerep	288
bpsetconfig	293
bpstsinfo	295
bpstuadd	301
bpstudel	310
bpstulist	312
bpsturep	319
bptestbpcd	327
bpup	330
bpverify	332
cat_convert	340
create_nbdb	346
duplicatetrace	348

importtrace	351
nbdb_admin	354
nbdb_backup	356
nbdb_move	357
nbdb_ping	358
nbdb_restore	359
nbdb_unload	360
nbdc	362
nbdelete	364
nbdevconfig	366
nbdevquery	373
nbemm	377
nbemmcmd	378
nbexecute	393
nbfirescan	395
nbftconfig	396
nbhba	404
nbjm	406
nbnos	407
nbpem	408
nbpemreq	410
nbpushdata	411
nbrb	418
nbshareddisk	419
nbstl	422
nbstlutil	424
nbsu	426
nbsvrgrp	431
restoretrace	434
set_ndmp_attr	436
SPSRecoveryAsst	439
tl4d	443
tl8d	444
tldd	447
tlhd	450
tlmd	453
tpautoconf	454
tpclean	458
tpconfig	461
tpext	476
tpreq	477
tpunmount	480
verifytrace	481

vltcontainers	484
vlteject	489
vltinject	493
vloffsitemedia	495
vltopmenu	499
vltrun	500
vmadd	505
vmchange	508
vmcheckxxx	516
vmdelete	518
vmoprcmd	520
vmphyinv	526
vmpool	530
vmquery	533
vmrule	537
vmupdate	539
vxlogcfg	542
vxlogmgr	548
vxlogview	552

Index	557
-------------	-----

Introduction

The purpose of this document is to provide you with a book that contains all of the NetBackup “man page” commands. This enables you to find a printable version of the command quickly and easily without searching through multiple books in the NetBackup Library.

This document contains detailed information about each NetBackup command pertinent to a UNIX system. Each command contains a brief description of the primary function of the command, a synopsis, and descriptions of each of the options listed in the synopsis. In addition, some commands contain notes and examples to help the user understand how to use the command.

Included in this document are the NetBackup Server and NetBackup Enterprise Server commands. In most cases, a command pertains to both NetBackup products. However, there are instances where portions or options within a command apply specifically to one product such as NetBackup Enterprise Server. In these situations, a note has been inserted in the text to identify the information as only information that only applies to one NetBackup product.

Command usage conventions

The following conventions are frequently used in the synopsis of command usage.

brackets []

The enclosed command line component is optional.

Vertical bar or pipe (|)

Separates optional arguments from which the user can choose. For example, when a command has the following format:

```
command arg1|arg2
```

In this example, the user can use either the *arg1* or *arg2* variable.

Navigating multiple menu levels

When navigating multiple menu levels, a greater-than sign (>) is used to indicate a continued action.

The following example shows how the > is used to condense a series of menu selections into one step:

- Select **Start > Programs > Veritas NetBackup > NetBackup Administration Console.**

The corresponding actions could be described in more steps as follows:

- 1 Click **Start** in the task bar.
- 2 Move your cursor to **Programs.**
- 3 Move your cursor to the right and highlight **Veritas NetBackup.**
- 4 Move your cursor to the right. First highlight and then click **NetBackup Administration Console.**

NetBackup command conventions

This document uses the following conventions when describing commands that are specific to NetBackup. Run these commands in the “Command Prompt” to see the results.

- Brackets [] indicate that the enclosed component of the command line is optional.
- Curly braces {} indicate an association between the enclosed options. For instance, {opt1 [opt2 ... optn]} means that if the command contains opt1, then the command may optionally contain opt2 ... optn.
- A vertical bar (or the pipe symbol) | separates optional arguments from which the user can choose. For example, if a command has the following format, you can choose *arg1* or *arg2* (but not both):
`command [arg1 | arg2]`
- Italics indicate that the information is user supplied. For example, the user supplies *policy*, *schedule*, and *filename* in the following command:
`bpbackup -p policy -s schedule filename`
- An ellipsis (...) means that you can repeat the previous parameter. For example, consider the following command:
`bpbackup [-S master_server [,master_server,...]] filename`
Here, the `-S` option requires the first master server name. Additional names can be added, separated by commas and followed by a file name as in:
`bpbackup -S mars,coyote,shark,minnow memofile.doc`

NetBackup Media Manager command notes

In addition, Media Manager has a set of commands that are for device management and are started or stopped by the NetBackup Device Manager service (`ltid`) as needed.

- `tpreq` and `tpunmount` are user commands for requesting tape mounts and unmounts for configured drives.
- `tpautoconf`, `tpclean`, `tpconfig`, and `vmopr cmd` are administrative commands for device management.
- `vmadd`, `vmchange`, `vmcheckxxx`, `vmdelete`, `vm pool`, and `vmquery`, `vmrule`, and `vmupdate` are administrative commands for media management.

NetBackup commands

acsd

NAME

acsd - Automated Cartridge System (ACS) process

SYNOPSIS

```
install_path\Volmgr\bin\acsd
```

DESCRIPTION

`acsd` interfaces with Media Manager to mount and unmount tapes automatically that are under Automated Cartridge System (ACS) control. If the Media Manager device configuration shows drives in an ACS robot, the NetBackup Device Manager service (`ltid`) runs `acsd`. Stopping `ltid` stops `acsd`.

`acsd` performs its tasks by sending requests to the STK LibAttach service, which communicates with the server that controls the Automated Cartridge System.

When the connection is established, `acsd` puts the ACS robot in the UP state and can mount and unmount tapes. If the connection cannot be established or Automated Cartridge System errors exist, `acsd` changes the robot to the DOWN state. In this state, `acsd` is still running and returns the robot to the UP state when the problem no longer exists.

Use the following to address and define drives in the Media Manager: ACS number, LSM number, Panel number, and Drive number.

Configure drive cleaning for ACS robots by using ACS library software. You cannot define the cleaning volumes by using Media Manager. In addition, you cannot use the `tpclean` command for cleaning operations on drives under ACS robotic control.

The Internet service port number for `acsd` must be in `%SystemRoot%\system32\drivers\etc\services`. To override the services file, create the file `install_path\Volmgr\database\ports\acsd` with a single line that contains the service port number for `acsd`. The default service port number is 13702.

You must have administrator privileges to run this command.

NOTES

This command applies only to NetBackup Enterprise Server.

ERRORS

Media Manager logs ACS and network errors to the Windows application event log. Log entries are also made when the state changes between UP and DOWN.

add_media_server_on_clients

NAME

add_media_server_on_clients - add Media Server on Clients

SYNOPSIS

```
<install_path>\NetBackup\bin\add_media_server_on_clients
```

DESCRIPTION

Run the `add_media_server_on_clients` command from a NetBackup server to synchronize the server list from the server's configuration with the server lists on the known clients.

The `add_media_server_on_clients` command attempts to connect to all configured clients (clients that are listed in backup policies).

For each client to which it can connect, `add_media_server_on_clients` updates the client's configuration, (if necessary) to include all the servers from the server's configuration.

backupdbtrace

\NAME

backupdbtrace - trace debug logs of backupdb (NetBackup image catalog backup) jobs

SYNOPSIS

```
<install_path>\NetBackup\bin\admincmd\backupdbtrace [-server name]  
[-job_id number] [-start_time hh:mm:ss] [-end_time hh:mm:ss]  
[-install_path path] mmdyy [mmdyy ...]
```

DESCRIPTION

backupdbtrace consolidates the debug log messages for the specified backup database jobs and writes them to standard output. It then sorts them by time. backupdbtrace attempts to compensate for time zone changes and the clock drift between remote servers and clients.

At a minimum, you must enable debug logging for administrator on the master server and for bptm and bpbkar on the media server. For best results, set the verbose logging level to 5. Then enable the debug logging for the following in addition to the processes already identified:

- bpdsm on the master server
- bpcd on all servers

If `-job_id` is specified, backupdbtrace uses this option as the sole criterion for selecting the backupdb job to trace. If option `-job_id` is not used, then backupdbtrace selects all the backupdb jobs that started on the days that the day stamps (*mmdyy*) specified. Use `-start_time` and `-end_time` options to examine the debug logs in the specified time interval.

backupdbtrace writes error messages to standard error.

You must have administrator privileges to run this command.

OPTIONS

`-server`

Name of the media server where the backupdb command is initiated. The default is the local host name.

`-job_id`

Job ID number of the backupdb job to analyze. Default is any job ID.

`-start_time`

Earliest time stamp to start analyzing the logs. Default is 00:00:00.

`-end_time`

Latest time stamp to finish analyzing the logs. Default is 23:59:59.

`mmddy`

One or more day stamps. This option identifies the log file names (log.mmddy for UNIX, mmddy.log for Windows) to analyze.

OUTPUT FORMAT

The format of an output line is:

`<daystamp>.<millisecs>.<program>.<sequence> <machine> <log_line>`

`daystamp`

The day of the log in *yyyymmdd* format.

`millisecs`

The number of milliseconds since midnight on the local machine.

`program`

The name of program (ADMIN, BPBKAR, BPCD, etc.) being logged.

`sequence`

Line number within the debug log file.

`machine`

The name of the NetBackup server or client.

`log_line`

The line that appears in the debug log file.

EXAMPLES

Example 1

The following example analyzes the log of `backupdb` job with job ID 5 executed on August 6, 2002.

```
backupdbtrace -job_id 5 080602
```

Example 2

The following example analyzes the log of all `backupdb` jobs that were ran on August 5, 2002 and August 17, 2002.

```
backupdbtrace 080502 081702
```

backuptrace

NAME

`backuptrace` - consolidate the debug logs for a NetBackup job

SYNOPSIS

```
<install_path>\NetBackup\bin\admincmd\backuptrace [-master_server name]
[-job_id number] [-birth_time number] [-policy_name name]
[-client_name name] [-start_time hh:mm:ss] [-end_time hh:mm:ss] mmddyy
[mmddyy...]
```

DESCRIPTION

Use the `backuptrace` utility to consolidate the debug logs for a specified NetBackup job[s]. The debug log messages relevant to the specified backup job[s] are written to standard output. Then the messages sort by time. The `backuptrace` utility attempts to compensate for time zone changes and the clock drift between remote servers and clients. The output is formatted so that it is relatively easy to sort or group by time stamp, program name, server name, or client name.

At a minimum, you must enable debug logging for the following:

- `nbpem` on the master server
- `bpbrm`, `bptm`, and `bpdm` on the media server
- `bpbkar` on the client.

For best results, set the verbose logging level to 5 and enable debug logging for the following in addition to the processes already identified:

- `bpdbm` and `bprd` on the master server
- `bpcd` on all servers and clients

Use the `backuptrace` utility for regular file system, database extension, and alternate backup method backup jobs.

You must have administrator privileges to run this command.

OPTIONS

`-master_server name`

Name of the master server. Default is the local host name.

`-job_id number`

Job ID number of the backup job to analyze.

`-birth_time number`
Birth time (seconds since 1970) of the backup job to analyze.

`-policy_name name`
Policy name of the jobs to analyze.

`-client_name name`
Client name of the jobs to analyze.

`-start_time hh:mm:ss`
Earliest time stamp to start analyzing the logs.

`-end_time hh:mm:ss`
Latest time stamp to finish analyzing the logs.

`mmddyy [mmddyy]`
One or more day stamps. This option identifies the log file names (log.mmddyy for UNIX, mmddyy.log for Windows) to analyze.

NOTES

Media Manager logs are not analyzed.

EXAMPLES

```
C:\Program Files\VERITAS\NetBackup\bin\admincmd\backuptrace  
policy weekly_bkups 051205 >/tmp/jobs.weekly_bkups
```

Use this utility to consolidate logs for all jobs that are started for the policy *weekly_bkups* on the specified date. Use the `-start_time`/`-end_time` arguments to limit the window for which the jobs are to be evaluated.

bmr

NAME

bmr - submit requests to the server daemon

SYNOPSIS

```
<install_path>\NetBackup\bin\bmr -operation change -resource {  
  restoretask | discovertask } [-client clientName] -state  
  numericStateCode -progress numericProgressCode  
  
<install_path>\NetBackup\bin\bmr -operation complete -resource {  
  restoretask | discovertask } [-client clientName] -state  
  numericStateCode  
  
<install_path>\NetBackup\bin\bmr -operation create -resource log  
  [-client clientName]  
  
<install_path>\NetBackup\bin\bmr -operation create -resource message  
  [-client clientName] -msg messageText  
  
<<install_path>\NetBackup\bin\bmr -operation pull -resource { info |  
  procedure } [-client clientName] -source sourceFileName -destination  
  destinationFileName
```

DESCRIPTION

The `bmr` client program runs on a BMR client and submits requests to the Bare Metal Restore server daemon. The operation and resource are specified as arguments.

When you initiate `bmr` from an external procedure in the repair environment on a restoring client, specify the path to the `bmr` command as follows:

```
%SystemDrive%\BMR\NBU\bin
```

At the first boot external procedure point, `bmr` is in `install_path\NetBackup\bin`.

OPTIONS

`-client clientName`

Name of the Bare Metal Restore client.

`-destination destinationFileName`

On pull operation, pathname of file to be created on the local host.

`-msg messageText`

Text message to be added to the log on the server.

`-operation operationName`
An operation to perform:
change
complete
create
pull

`-progress numericProgressCode`
A numeric progress code, used internally by Bare Metal Restore.

`-resource resourceName`
A resource on which to perform the operation:
discovertask
info
log
message
procedure
restoretask

`-source sourceFileName`
On pull operation, name of file to retrieve from database.

`-state numericStateCode`
A numeric state code, used internally by Bare Metal Restore.

EXAMPLES

Example 1

Change the status of a discovery task:

```
bmrc -operation change -resource discovertask -client  
clientName -state numericStateCode -progress  
numericProgressCode
```

Example 2

Change the status of a restore task:

```
bmrc -operation change -resource restoretask -client  
clientName -state numericStateCode -progress  
numericProgressCode
```

Example 3

Complete a discovery task and set a final status code:

```
bmrc -operation complete -resource discovertask -client  
clientName -status numericStatus
```

Example 4

Complete a restore task and set a final status code:

```
bmr -operation complete -resource restoretask -client  
clientName -status numericStatus
```

Example 5

Create a log on the server from standard input to this command:

```
bmr -operation create -resource log -client clientName
```

Example 6

Create a message, which is added to a log on the server:

```
bmr -operation create -resource message -client clientName  
-msg message text
```

Example 7

Pull a file from the server:

```
bmr -operation pull -resource info -client clientName  
-source sourceFileName -destination destinationFileName
```

Example 8

Pull an external procedure from the server:

```
bmr -operation pull -resource procedure -client clientName  
-source sourceFileName -destination destinationFileName
```

NOTES

If you use NetBackup Access Management and the user credentials and machine credentials are expired, renew them before you perform prepare-to-restore operations. Use the `bpnbat` command and `-Login` option to renew your user credentials. Use the `bpnbat` command and `-LoginMachine` option to renew the machine credentials.

Specifying `-?` displays the command's usage statement when it is the only option on the command line.

bmrconfig

NAME

bmrconfig - change configuration settings

SYNOPSIS

```

<install_path>\NetBackup\bin\bmrconfig -help [-resource resourceType
  [-platform win | hp | aix | solaris | linux] [-manager ldm | lvm |
  native | sfw | svm | vxvm] [-operation add | change | clearAll | delete
  | display | list | map]]
<install_path>\NetBackup\bin\bmrconfig -operation verify -client
  clientName -configuration configName
<install_path>\NetBackup\bin\bmrconfig -operation initialize -resource
  disk | network | all -client clientName -configuration configName
  -sourceconfiguration source_configName
<install_path>\NetBackup\bin\bmrconfig -operation initialize -resource
  disk | network | all -client clientName -configuration configName
  -sourceclient source_clientName -sourceconfiguration source_configName
<install_path>\NetBackup\bin\bmrconfig -operation add | change | clearAll
  | delete | display | list | map -resource resourceType [-name
  resourceName] [-manager ldm | lvm | native | sfw | svm | vxvm] -client
  clientName -configuration configName [-attributes "key=value"
  ["key=value" ...]]

```

DESCRIPTION

The `bmrconfig` command changes a configuration's system, network, volume, driver, and NetBackup settings. The read-only current and discovered configurations cannot be changed; use the `bmrsc` command to create a copy of a configuration that you can change.

OPTIONS

`-attributes`

Attributes of the resource are specified as name-value pairs. The name is always an alphanumeric string. The value is free form but must be double quoted. To determine the specific set of attributes that apply to a resource, use `bmrconfig -operation list -resource resourceType`.

`-client clientName`

The NetBackup client name.

`-configuration configName`
The configuration to operate on.

`-force`
Forces the removal of a resource and all of its dependent resources.

`-help`
Prints a command line usage message when `-help` is the only option on the command line.

`-manager`
The volume manager that controls the resource. Volume managers are as follows:
`ldm` - Windows Logical Disk Manager
`lvm` - AIX or HP-UX Logical Volume Manager
`native` - the volume manager native to the operating system
`sfw` - Veritas Storage Foundation for Windows
`svm` - Solaris Volume Manager
`vxvm` - Veritas Volume Manager

`-name resourceName`
The name of the resource to act on. The various volume managers determine the valid characters in a resource name.

`-operation operation_name`
The operation to perform. Operations are as follows:
`add` - adds a resource to the configuration
`change` - changes specific attributes of a resource
`clearAll` - removes all resources except disks from a disk group
`delete` - removes a resource from the configuration
`display` - prints high-level information about the resource
`help` - prints all the resources that are required and optional attributes and values
`initialize` - initializes a configuration's hardware from a discovered configuration
`list` - prints all the instances of the specified resource type
`map` - maps a resource that includes dependent resources, from the original configuration to the working configuration
`verify` - checks that a config has sufficient data for a restore to succeed

`-resource resourceType`
The type of the resource on which the operation is performed. Resource types are as follows:

`all` - all resources
`accesspath` - a Windows access path
`disk` - a physical storage device
`diskgroup` - a logical grouping of disks
`diskset` - a Solaris Volume Manager disk set
`driveletter` - a Windows drive letter
`esm` - backup client identity
`filesystem` - a file system for UNIX, Linux, and Windows
`gateway` - a network gateway
`host` - a network server
`hotfix` - a Windows hot fix
`hotsparepool` - a set of the slices that are used for SVM failover
`ip` - network identity
`license` - a product license key
`logicaldrive` - a Windows extended partition; first one implicitly adds container
`logicalvolume` - an AIX or HP-UX logical volume
`metadb` - an SVM database replica slice
`mountpoint` - a path that serves as an access point to a volume
`msd` - a mass storage driver
`multidevice` - a Linux multidevice
`network` - a sub network
`nic` - a network interface card
`nicpkg` - a network interface card driver
`partition` - Windows primary partition
`physicalvolume` - an AIX or HP-UX physical volume
`slice` - a Solaris slice; equivalent to volume
`softpart` - an SVM soft partition
`volume` - a logical division of a disk or a disk group
`volumegroup` - an AIX or HP-UX volume group

`-sourceconfiguration` *source_configName*

The configuration that is the source in an initialized configuration operation.

```
-sourceclient source_clientName
```

The client that serves as the source in an initialized configuration operation. If a source client is not specified, the configuration comes from the list of discovered configurations.

EXAMPLES

Example 1

List the physical volumes in a configuration for client aixp31:

```
bmrconfig -operation list -resource physicalvolume  
-configuration current -client aixp31
```

Example 2

Display the attributes of a physical volume for client aixp31:

```
bmrconfig -operation display -resource physicalvolume  
-configuration current -client aixp31 -name hdisk0
```

Example 3

List the volume groups in a configuration for client aixp31:

```
bmrconfig -operation list -resource volumegroup  
-configuration current -client aixp31
```

Example 4

Display the attributes of a volume group for client aixp31:

```
bmrconfig -operation display -resource volumegroup  
-configuration current -client aixp31 -name rootvg
```

Example 5

Initialize the new configuration with the discovered hardware for client aixp31:

```
bmrconfig -operation initialize -resource config  
-configuration mynew -client aixp31 -sourceconfiguration  
discover
```

Example 6

Add a volume group to a configuration for client aixp31:

```
bmrconfig -operation add -configuration mynew -client aixp31  
-resource volumegroup -name rootvg -attributes  
physicalvolume=hdisk1
```

Example 7

Add a disk to a volume group for client aixp31 (requires a full list of physical volumes to be specified):

```
bmrconfig -operation modify -configuration mynew -client  
aixp31 -resource volumegroup -name rootvg -attributes  
physicalvolume=hdisk1 physicalvolume=hdisk0
```

Example 8

Remove a physical volume from a volume group for client aixp31:

```
bmrconfig -operation modify -configuration mynew -client  
aixp31 -resource volumegroup -name rootvg -attributes  
physicalvolume=hdisk0
```

Example 9

Map a volume group from the original configuration for client aixp31:

```
bmrconfig -operation map -configuration mynew -client aixp31  
-resource volumegroup -name rootvg
```

NOTES

If you use NetBackup Access Management and the user credentials and the machine credentials expire, renew them before you perform prepare-to-restore operations. Use the `bpnbat` command and `-Login` option to renew your user credentials. Use the `bpnbat` command and `-LoginMachine` option to renew the machine credentials.

Specifying `-?` displays a synopsis of command usage when it is the only option on the command line.

SEE ALSO

`bmrs`

bmrepadm

NAME

bmrepadm - manage external procedures

SYNOPSIS

```
<install_path>\NetBackup\bin\bmrepadm [-data] -list [pattern]
<install_path>\NetBackup\bin\bmrepadm [-data] -delete procedureName
<install_path>\NetBackup\bin\bmrepadm [-data] -extract procedureName
<install_path>\NetBackup\bin\bmrepadm [-data] -add fileName
```

DESCRIPTION

The `bmrepadm` command lists, adds, extracts, or deletes external procedures from the database. The `bmrepadm` command is installed and runs on the NetBackup master server that is licensed for BMR.

A procedure name (*procedureName*) must be in the form *type.os* or *name_type*.

type is one of the following strings:

- prediscover
- preformat
- prerestore
- postrestore
- firstboot

os is one of following strings:

- aix
- hp
- linux
- sol
- win

name is the name of a Bare Metal Restore client.

OPTIONS

`-add pathName`

Add the external procedure in *pathName* to the database. The last component of *pathName* must be a valid external *procedureName*.

-data

Normally `bmrepadm` manipulates an external procedure. When `-data` is specified, an arbitrary user-supplied data file is manipulated instead. This option also relaxes all of the naming convention rules for procedure and file name argument values. The names of data files can be anything except a valid external procedure name.

-delete *procedureName*

Delete the *procedureName* external procedure from the database. The *procedureName* must be a valid external procedure name.

-extract *procedureName*

Extract an external procedure from the database and write it to the current directory. The procedure name must be a valid external *procedureName*.

-list [*pattern*]

Lists the entries (external procedures or user-supplied data files) in the database. Only the entries that match the *pattern* are listed; if no *pattern* is specified, all entries in the database are listed. The "*" character may be used in the pattern to match any sequence of characters.

NOTES

`bmrepadm` does not validate client names (that is, you can add an external procedure for a nonexistent client).

If you use NetBackup Access Management and if your user credentials and the machine credentials expire, renew them before you perform prepare-to-restore operations. Use the `bpnbat` command and `-Login` option to renew your user credentials. Use the `bpnbat` command and `-LoginMachine` option to renew the machine credentials.

Specifying `-?` displays a synopsis of command usage when it is the only option on the command line.

EXAMPLES

Example 1

Add a data file:

```
bmrepadm -data -add nameNotMatchingEPname
```

Example 2

List the data files:

```
bmrepadm -data -list
```

Example 3

Add an external procedure that runs for all Solaris clients after the NetBackup restore phase of restoration:

```
bmrepadm -add /example/path/postrestore.sol
```

Example 4

Add an external procedure that runs before the disks are formatted on a client that is named zanzibar:

```
bmrepadm -add.../relative/path/zanzibar_preformat
```

bmrprep

NAME

bmrprep - prepare a client for restore or discovery

SYNOPSIS

```
<install_path>\NetBackup\bin\bmrprep -discover -newconfig  
configurationName -srt srtName [-client clientName -config  
configurationName] -address clientAddress -default defaultGateway  
-netmask netmask -mac clientMacAddress -server serverAddress -console  
consoleDeviceName -architecture architectureName [-gateway  
serverGateway] [-logging] [-runep]
```

DESCRIPTION

The `bmrprep` command prepares a Bare Metal Restore client for a restore or for a hardware discovery process. This command only runs on the Bare Metal Restore master server.

OPTIONS

`-address clientAddress`

(UNIX and Linux clients only.) IP address of the client, in dotted decimal notation. Required only for a `-discover` operation; optional if `-client` and `-config` options are specified.

`-architecture architectureName`

(UNIX and Linux clients only.) Architecture of the client to be discovered. Required only for a `-discover` operation; optional if `-client` and `-config` options are specified.

`-client clientName`

Name of the client to restore.

`-config configurationName`

Name of the configuration to use.

`-console consoleDeviceName`

(UNIX and Linux clients only.) Name of the console device to use during discovery. Required only for a `-discover` operation; optional if you specify the `-client` and `-config` options or use media boot.

- default *defaultGateway*
(*UNIX and Linux clients only.*) Default gateway address, in dotted decimal notation. Required only for a `-discover` operation; optional if you specify the `-client` and `-config` options or use media boot.
- discover
(*UNIX and Linux clients only.*) Perform a hardware discovery. Cannot be used with `-restore`.
- enddate *enddate*
Date for point-in-time restores.
The date and the time format depend on your regional settings.
- gateway *serverGateway*
(*UNIX and Linux clients only.*) Gateway to a NetBackup server, in dotted decimal notation. Required only for a `-discover` operation.
- import
Import non-system volume groups.
For more information about how to use this flag, see "Prepare to Restore Client Dialog Box" in the *Bare Metal Restore Administrator's Guide*.
- logging
Enable logging.
- mac *clientMacAddress*
(*UNIX and Linux clients only.*) MAC address of the client. Required only for a `-discover` operation. (Exception: optional if the IP address is configured during initial program load (IPL)); optional if you specify the `-client` and `-config` options or use media boot.
- netmask *netmask*
(*UNIX and Linux clients only.*) Netmask of the client, in dotted decimal notation. Required only for a `-discover` operation; optional if `-client` and `-config` options are specified.
- newconfig *configurationName*
(*UNIX and Linux clients only.*) Name to be given to the discovered configuration.
- policy *policyName*
Name of the policy to be used.
- quickformat
(*Microsoft Windows clients only.*) Quickly format Windows partitions.
- restore
Perform a normal restore. Cannot be used with `-discover`.

`-runep`

Run external procedures.

`-server serverAddress`

(*UNIX and Linux clients only.*) A NetBackup server address, in dotted decimal notation. Required only for a `-discover` operation; optional if `-client` and `-config` options are specified.

`-srt srtName`

Name of the shared resource tree to use.

`-systemOnly`

Restore system volume groups only.

For more information about how to use this option, see "Prepare to Restore Client Dialog Box" in the *Bare Metal Restore Administrator's Guide*.

NOTES

If you use NetBackup Access Management and your user credentials and the machine credentials expire, to renew them before you perform prepare-to-restore operations. Use the `bpnbat` command and `-Login` option to renew your user credentials. Use the `bpnbat` command and `-LoginMachine` option to renew the machine credentials.

The format that you use for date and time values in NetBackup commands varies according to your regional settings.

To access the regional settings, double-click Regional Settings in the Windows Control Panel.

For more information about regional settings, see the Microsoft documentation.

Specifying `-?` displays a synopsis of command usage when it is the only option on the command line.

SEE ALSO

`bpnbat` (1M)

bMrs

NAME

bMrs - manage resources in the Bare Metal Restore database

SYNOPSIS

```
<install_path>\NetBackup\bin\bMrs -operation delete -resource config  
-name configName -client clientName -resource client -name clientName  
-resource package -name packageName -resource srt -name srtName  
-resource discovertasklog -id idvalue -resource restoretasklog -id  
idvalue  
  
<install_path>\NetBackup\bin\bMrs -operation complete -resource  
discovertask -client clientName -status numericStatus -resource  
restoretask -client clientName -status numericStatus  
  
<install_path>\NetBackup\bin\bMrs -operation verify -resource srt -name  
srtName [-client clientName]  
  
<install_path>\NetBackup\bin\bMrs -operation copy -resource config -name  
configName -client clientName -destination newConfigName  
  
<install_path>\NetBackup\bin\bMrs -operation retrieve -resource config  
-client clientName -destination newConfigName [-enddate date]  
[-epochenddate eEnddate] [-policy policyName]  
  
<install_path>\NetBackup\bin\bMrs -operation import -resource config  
-path bundlePath [-client clientName] [-destination newConfigName]  
  
<install_path>\NetBackup\bin\bMrs -operation list -resource resourceName
```

DESCRIPTION

The **bMrs** command manages resources in the Bare Metal Restore database. The **bMrs** command runs on the master server.

OPTIONS

-client *clientName*
Name of the Bare Metal Restore client.

-destination *newConfigName*
Name of the destination configuration to create.

-enddate *date*
The date for point-in-time restore configurations. If both **-enddate** and **-epochenddate** are specified, **-epochenddate** takes precedence.

The date and the time format depend on your regional settings.

`-epochenddate eEnddate`

The date for the point-in-time restore configurations, which is specified in the number of seconds since January 1, 1970. If both `-enddate` and `-epochenddate` are specified, `-epochenddate` takes precedence.

`-id idvalue`

Database record ID of the resource to use for this operation. It is either `discoverTaskLogId` or `restoreTaskLogId`.

`-name value`

Name of the resource to use for this operation: `clientName`, `configName`, `packageName`, or `srtName`.

`-operation operationName`

An operation to perform:

`complete`

`copy`

`delete`

`import`

`list`

`retrieve`

`verify`

`-path bundlePath`

Pathname to a bundle file created by the `bmrsavecfg` command.

`-policy policyName`

Name of the policy to be used.

`-resource resourceName`

A resource on which to perform the operation. The allowed resource names vary with operation specified. For `-operation list`, the following resources are supported:

`bootserver`

`client`

`config`

`discovertask`

`discovertasklog`

`package`

`restoretask`

`restoretasklog`

```
srt  
-status numericStatus
```

A numeric completion status code, used internally by Bare Metal Restore.

EXAMPLES

Example 1

List the configurations in the BMR database:

```
bmr -operation list -resource config
```

Example 2

Copy the current configuration (read-only) and create a new configuration (*mynew*) that you can edit for client *aixp31*:

```
bmr -operation copy -resource config -name current -client  
aixp31 -destination mynew
```

Example 3

Delete configuration *mynew* for client *aixp31*:

```
bmr -operation delete -resource config -name mynew -client  
aixp31
```

Example 4

Verify the integrity of shared resource tree *aixsrt*:

```
bmr -operation verify -resource srt -name aixsrt
```

NOTES

Specifying `-?` displays a synopsis of command usage when it is the only option on the command line.

If you use NetBackup Access Management and your user credentials and the machine credentials expire, renew them before you perform prepare-to-restore operations. Use the `bpnbat` command and `-Login` option to renew your user credentials. Use the `bpnbat` command and `-LoginMachine` option to renew the machine credentials.

The required date and time values format in NetBackup commands varies according to your locale or regional settings.

To access the regional settings, double-click Regional Settings in the Windows Control Panel.

SEE ALSO

`bmr`

bmrstadm

NAME

`bmrstadm` - create and manage shared resource trees and create bootable CD images

SYNOPSIS

```
<install_path>\NetBackup\bin\bmrstadm
```

DESCRIPTION

The `bmrstadm` command launches the Create Shared Resource Tree wizard. Use the Create Shared Resource Tree wizard on a BMR boot server to do the following:

- Create a new shared resource tree.
- Create a bootable CD image that contains a copy of an existing shared resource tree.
- Install additional software into an existing shared resource tree.
- Copy an existing shared resource tree to a new location.
- Delete an existing shared resource tree.

bparchive

NAME

bparchive - archive files to the NetBackup server

SYNOPSIS

```
<install_path>\NetBackup\bin\bparchive [-p policy] [-s schedule] [-L  
  progress_log [-en]] [-S master_server [,master_server,...]] [-t  
  policy_type] [-w [hh:mm:ss]] [-help] [-k "keyword_phrase"] -f listfile  
  | filenames
```

DESCRIPTION

bparchive processes files listed on the command line or in the file that is specified with the `-f listfile` option. Any file path that is entered can be a file name or a directory name. If the list of files includes a directory, bparchive archives all files and subdirectories of that directory. It starts at the directory itself.

By default, you return to the system prompt after bparchive is successfully submitted. The command works in the background and does not return completion status directly to you. Use the `-w` option to change bparchive to work in the foreground and to return completion status after a specified time period.

bparchive writes informative and error messages to a progress-log file if the file is created. Create the file before you run the bparchive command and specify it with the `-L progress_log` option. If bparchive cannot archive any of the requested files or directories, use the progress log to determine the reason for the failure.

If you create an `install_path\NetBackup\logs\bparchive\` directory with write access, bparchive creates a debug log file in this directory to use for troubleshooting.

The following restrictions apply to this command:

- To archive a file with bparchive, you must have permission to delete the file and the file must not be read-only. Otherwise, NetBackup saves the files but does not delete them from the disk.
- bparchive does not archive the "." or ".." directory entries, and does not archive disk-image backups.

OPTIONS

- `-p policy`
Names the policy to use for the user archive. If it is not specified, the NetBackup server uses the first policy it finds that includes the client and a user archive schedule.
- `-s schedule`
Names the schedule to use for the user archive. If it is not specified, the NetBackup server uses the first user archive schedule it finds in the policy it currently uses. (See the `-p` option.)
- `-S master_server`
Specifies the name of the NetBackup master server. The default is the server designated as current on the Servers tab of the **Specify NetBackup Machines** dialog box. To display this dialog box, start the Backup, Archive, and Restore user interface on the client. Then click **Specify NetBackup Machines** on the File menu.
- `-t policy_type`
Specifies one of the following numbers that corresponds to the policy type. The default for Windows clients is 13. For Netware clients the default is 10. The default for all others is 0:
- 0 = Standard
 - 4 = Oracle
 - 6 = Informix-On-BAR
 - 7 = Sybase
 - 10 = NetWare
 - 13 = MS-Windows
 - 14 = OS/2
 - 15 = MS-SQL-Server
 - 16 = MS-Exchange-Server
 - 19 = NDMP
- Note that the following policy types apply only to NetBackup Enterprise Server.
- 11 = DataTools-SQL-BackTrack
 - 17 = SAP
 - 18 = DB2
 - 20 = FlashBackup
 - 21 = Split-Mirror
 - 22 = AFS

`-L progress_log [-en]`

Specifies the name of an existing file in which to write progress information.

For example: `c:\proglog`.

The default is not to use a progress log.

Include the `-en` option to generate a log in English. The name of the log contains the string `_en`. This option is useful to support personnel in a distributed environment where different locales may create logs of various languages.

`-w [hh:mm:ss]`

Causes NetBackup to wait for a completion status from the server before returning you to the system prompt.

You can optionally specify a wait time in hours, minutes, and seconds. The maximum wait time you can specify is 23:59:59. If the wait time expires before the archive is complete, the command exits with a timeout status.

The archive, however, still completes on the server.

If you use `-w` without specifying the wait time or if you specify a value of 0, NetBackup waits indefinitely for the completion status.

`-help`

Prints a command line usage message when `-help` is the only option on the command line.

`-k keyword_phrase`

Specifies a keyword phrase that NetBackup associates with the image created by this archive operation. You then can restore the image by specifying the keyword phrase with the `-k` option on the `bprestore` command.

The keyword phrase is a textual description of the archive that is a maximum of 128 characters in length. All printable characters are permitted including space (" ") and period (".").

Enclose the phrase in double quotes ("...") or single quotes ('...').

The default keyword phrase is the null (empty) string.

`-f listfile`

Specifies a file (*listfile*) that contains a list of files to be archived and can be used instead of the *filenames* option. In *listfile*, place each file path on a separate line.

The required file list format depends on whether the files have spaces, newlines, or returns in the names.

To archive the files that do not have spaces or newlines or returns in the names, use the following format:

filepath

Where *filepath* is the path to the file you want to archive. For example:

```
c:\Programs
```

```
c:\winnt
```

```
c:\documents\old_memos
```

To archive the files that have spaces or newlines or returns in the names, use this format:

filepathlen filepath

Where *filepath* is the path to the file you want to archive and *filepathlen* is the number of characters in the file path.

For example:

```
11 c:\Programs
```

```
8 c:\winnt
```

```
22 c:\documents\old memos
```

filenames

Names one or more files to be archived and can be used instead of the `-f` option.

Any files that you specify must be listed at the end, after all other options.

EXAMPLES

Example 1

Archive a single file:

```
bparchive c:\usr\user1\file1
```

Example 2

Archive the files that are listed in a file that is named `archive_list`:

```
bparchive -f archive_list
```

Example 3

Associate keyword phrase "Archive My Home Directory 02/02/06" to the archive of directory `c:\home\kwc` and use a progress log that is named

```
c:\home\kwc\arch.log.
```

```
bparchive -k "Archive My Home Directory 02/02/06" \-L  
c:\home\kwc c:\home\kwc\arch.log
```

bpbacup

NAME

bpbacup - back up files to the NetBackup server

SYNOPSIS

```
install_path\NetBackup\bin\bpbacup [-p policy] [-s schedule] [-S  
master_server...] [-t policy_type] [-L progress_log [-en]] [-w  
[hh:mm:ss]] [-help] [-k "keyword_phrase"] -f listfile | filenames  
  
install_path\NetBackup\bin\bpbacup -i [-p policy] [-h hostname] [-s  
schedule] [-S master_server...] [-t policy_type] [-L progress_log  
[-en]] [-w [hh:mm:ss]] [-k "keyword_phrase"]  
  
install_path\NetBackup\bin\bpbacup -dssu DSSUname
```

DESCRIPTION

bpbacup starts either of the following processes:

On clients

The first form in the command synopsis, bpbacup starts a user backup equivalent to what is performed by using the interface on the client. This type of backup can be started from any NetBackup client to back up files from that client.

The bpbacup command processes the files that you list on the command line or in the file that you specify with the *-f listfile* option. A file path can be a file name or a directory name. If the named files include a directory, bpbacup backs up all files and subdirectories of that directory; it starts at the directory itself.

On master servers

The second form in the command synopsis, bpbacup starts an immediate manual backup of a client. This variation requires the *-i* option on the bpbacup command and is available only to the administrator on the master server. It is equivalent to when you start a manual backup from the NetBackup Administration Console. Use the *-h* option to specify the host.

Since progress logs are written only on clients and this form of bpbacup is run from the master server only, the *-L* option is undefined.

The following restrictions apply to this command:

- You must be the owner of the file or an administrator to back up a file with bpbacup.

- You can back up files and the directories that other users own if you have the necessary permissions.
- bpbackup does not back up the "." or ".." directory entries.

By default, you return to the system prompt after bpbackup is successfully submitted. The command works in the background and does not return completion status directly to you. The `-w` option lets you change this behavior so the command works in the foreground. It returns completion status after a specified time period.

If you create the file before you run the bpbackup command and then specify the file with the `-L progress_log` option, the following occurs: bpbackup writes informative and error messages to a progress-log file. If bpbackup cannot back up the requested files or directories, use the progress log to determine the reason for the failure.

If you create a directory that is named `install_path\NetBackup\logs\bpbackup` with write access, bpbackup creates a debug log file in this directory to use for troubleshooting.

OPTIONS

`-p policy`

Names the policy to use for the backup.

If this option is not specified, NetBackup uses the first policy it finds that includes the client and a user backup schedule.

The `-p` option is required for an immediate-manual backup (`-i` option).

`-i`

Starts an immediate-manual backup. It is equivalent to when you start a manual backup from the NetBackup administrator interface. You must be the administrator on the master server to use the `-i` option.

`-dssu DSSUname`

NetBackup immediately runs the schedule that is associated with the disk staging storage unit. The `-i` option is the implied behavior and therefore is not necessary.

`-h hostname`

Names the client host on which to run the backup. If it is not specified, NetBackup runs the backup on all clients in the policy.

`-s schedule`

Names the schedule to use for the backup. If it is not specified, the NetBackup server uses the first user backup schedule it finds for the client in the policy currently in use.

See the `-p` option.

`-S master_server [,master_server, ...]`

Specifies the name(s) of the NetBackup master server(s). The default is the server designated as current on the Servers tab of the **Specify NetBackup Machines** dialog box. To display this dialog box, start the Backup, Archive, and Restore user interface on the client. Then click **Specify NetBackup Machines** on the File menu.

`-t policy_type`

Specifies one of the following numbers that corresponds to the policy type. The default for Windows clients is 13, for Netware clients the default is 10, and the default for all others is 0:

0 = Standard

4 = Oracle

6 = Informix-On-BAR

7 = Sybase

10 = NetWare

13 = MS-Windows

14 = OS/2

15 = MS-SQL-Server

16 = MS-Exchange-Server

19 = NDMP

Note that the following policy types apply only to NetBackup Enterprise Server.

11 = DataTools-SQL-BackTrack

17 = SAP

18 = DB2

20 = FlashBackup

21 = Split-Mirror

22 = AFS

`-L progress_log [-en]`

Specifies the name of a file in which to write progress information. NetBackup creates the file if it does not exist.

For example: `c:\proglog`

The default is not to use a progress log.

Include the `-en` option to generate a log in English. The name of the log contains the string `_en`. This option is useful to support personnel in a distributed environment where different locales may create logs of various languages.

`-w [hh:mm:ss]`

Causes NetBackup to wait for a completion status from the server before returning you to the system prompt.

You can optionally specify a wait time in hours, minutes, and seconds. The maximum wait time you can specify is 23:59:59. If the wait time expires before the backup is complete, the command exits with a timeout status. The backup, however, still completes on the server.

The `bpbackup -w` option causes the shell to wait for a return code. The operating system shell can only return one return code. Therefore, if you use `-w` without specifying a wait time or you specify a value of 0, NetBackup waits indefinitely for the completion status.

You can start a *manual* or an *administrative* backup using `bpbackup -i` along with the `-w` function. This type of backup has the potential to start multiple jobs because it is based on policy attributes. If the manual backup starts multiple jobs, the `-w` function still only returns one return code to the shell.

If you use `-i` with `-w` and more than one job begins, NetBackup waits until all jobs complete before it returns a completion status. However, because NetBackup only returns one status code to the shell, the job ID that the status code belongs to is unknown.

If multiple clients are running multiple jobs and Allow Multiple Data Streams is not selected, use `-h` to restrict the operation to one client. However, if Allow Multiple Data Streams is selected in the policy and the selected client has multiple jobs, the returned status code is again unknown.

`-help`

Prints a command line usage message when `-help` is the only option on the command line.

`-k keyword_phrase`

Specifies a keyword phrase that NetBackup associates with the image that this backup operation creates. You then can restore the image by specifying the keyword phrase with the `-k` option on the `bprestore` command.

If you use the `-i` option with `-k`, NetBackup establishes an association between the keyword phrase and the backup policy and image.

The keyword phrase is a textual description of the backup that is a maximum of 128 characters in length. All printable characters are permitted including space (" ") and period ("."). Enclose the phrase in double quotes ("...") or single quotes ('...').

The default keyword phrase is the null (empty) string.

`-f listfile`

Specifies a file (*listfile*) that contains a list of files to back up. You can use this option instead of the *filenames* option, but you cannot use it with the `-i` option. List each file on a separate line.

The format that is required for the file list depends on whether the files have spaces or returns in the names.

To back up the files that do not have spaces or returns in the names, use the following format:

filepath

Where *filepath* is the path to the file you want to back up. For example:

```
c:\Programs
```

```
c:\winnt
```

```
c:\documents\old_memos
```

To back up the files that have spaces or returns in the names, use the following format:

filepathlen filepath

Where *filepath* is the path to the file you want to back up and *filepathlen* is the number of characters in the file path.

For example:

```
11 c:\Programs
```

```
8 c:\winnt
```

```
22 c:\documents\old memos
```

filenames

Names one or more files to back up. You can use this option instead of the `-f` option, but you cannot use it with the `-i` option. You must list any files that you specify at the end, following all other options.

EXAMPLES

Example 1

Performs a user backup of a single file, enter:

```
bpbackup c:\users\user1\file1
```

Example 2

The following command starts a user backup of the files that are listed in a file that is named `backup_list`:

```
bpbackup -f backup_list
```

Example 3

The following command (all on one line) starts an immediate-manual backup of the client host named diablo, in the policy named cis_co. The policy type is Standard policy and is in the configuration on the master server named hoss.

```
bpbackup -p cis_co -i -h diablo -S hoss -t 0
```

Example 4

The following command associates the keyword phrase "Backup My Home Directory 01/01/01" to the user backup of the directory `c:\home\kwc`. (Enter the command on one line.) The progress log is as follows:

```
bpbackup -k "Backup My Home Directory 01/01/01" -L  
c:\home\kwc\bkup.log c:\home\kwc
```

Example 5

The following command associates the keyword phrase "Policy Win 01/01/01" to the immediate-manual backup of the client host named slater in the policy named win_nt_policy. (Enter the command all on one line.)

```
bpbackup -k "Policy Win 01/01/01" -i -h slater -p  
win_nt_policy -t 13
```

FILES

```
install_path\NetBackup\logs\bpbackup\*.log
```

bpbakupdb

NAME

bpbakupdb - back up NetBackup image catalogs

SYNOPSIS

```
install_path\NetBackup\bin\admincmd\bpbakupdb [{"-dpath disk_path"} |  
  {"-tpath tape_device_path [-m media_ID]} | {"-opath optical_device_path  
  [-m media_ID]}] [{"-nodbpaths"}] [{"-v"}] [path...]  
  
install_path\NetBackup\bin\admincmd\bpbakupdb [-p policy_name -s  
  sched_label]
```

DESCRIPTION

bpbakupdb initiates a backup of one or more NetBackup image catalogs that are specified on the bpbakupdb command line. bpbakupdb also backs up the default NetBackup catalogs, unless the command line contains `-nodbpaths`. If the command line specifies a destination, the backup is stored there.

Otherwise, the backup is stored at the default location for backups of the NetBackup internal databases, which are called catalogs.

You can specify the default catalogs and the backup destination:

- The default paths to the NetBackup image catalogs are part of the NetBackup configuration. bpbakupdb uses the set of configured NetBackup catalog paths as the default value for the path option.
- The NetBackup configuration includes two destinations (media IDs or disk pathnames) for NetBackup catalog backups. bpbakupdb uses the destination not recently used as its default value for the backup destination.

The *NetBackup Administrator's Guide* explains how to configure and display these values.

You must have administrator privileges to initiate this command.

Only one copy of bpbakupdb can run at a time. The bpbakupdb command fails if it determines that a NetBackup catalog backup is already running. If bpbakupdb fails because other backups are in progress, retry when there is no other NetBackup activity.

If bpbakupdb fails with "cannot find Internet service bpcd/tcp," the service or the protocol pair bpcd, tcp is not defined on the local system. On Windows, look for a bpcd or a tcp entry in the following file:

```
install_path\system32\drivers\etc\services.
```

The *NetBackup Administrator's Guide* provides additional information on how to back up NetBackup catalogs. The NetBackup utility `bprecover` recovers the catalogs that `bpbackupdb` has backed up. The NetBackup troubleshooting guide (Windows version) provides information on how to restore the NetBackup catalogs if a disaster recovery is required.

OPTIONS

You can specify a list of NetBackup image catalogs with the following options or default to the catalogs that are specified in the NetBackup configuration:

`-dpath disk_path`

`-tpath tape_device_path`

`-opath optical_device_path`

`-tpath`

Specifies a tape raw device path as the destination for the backup.

`-opath`

Specifies an optical raw device path as the destination for the backup.

`-dpath`

Specifies a raw disk path as the destination for the backup.

If the media for the catalog backup is non-robotic, a mount request occurs. Then the catalog backup waits until the mount request is granted or denied. The `MEDIA_MOUNT_TIMEOUT` attribute does not apply to this request.

The NetBackup Device Manager service and NetBackup Volume Manager service do not need to be active when you use the `-dpath` option.

If `-tpath` or `-opath` is used, the device name can be an NDMP device name. The syntax for an NDMP device name is *client:drivename*. An NDMP device name can contain / but it cannot contain /ndmp.

`-m media_ID`

Specifies the media ID for the NetBackup database backup. This option is meaningful when either `-tpath` or `-opath` is used. Media Manager uses the media ID for removable media to verify that the correct media is mounted. The media ID string length is between one and six characters, and the string can be either uppercase or lowercase.

`-help`

Prints a command line usage message when `-help` is the only option on the command line.

`-nodbpaths`

Do not back up the configured NetBackup catalogs. If this option is present, you must specify at least one catalog path on the command line. If this option is absent, `bpbackupdb` backs up the catalogs that NetBackup

configures for catalog backups. It also configures any catalog that the *path* option lists.

-p policy_name -s sched_label

The *-p* and *-s* options are used to launch a policy-based, hot catalog backup.

-v

Selects the verbose mode. This option causes bpbackupdb to log additional information for debugging purposes. The information goes into the NetBackup administration daily debug log. This option is meaningful only when NetBackup enables the debug log function (*install_path\netbackup\logs\admin* directory defined).

path...

Back up these NetBackup catalogs. This path is a list of absolute pathnames.

To back up a NetBackup catalog on the master server, specify the catalog backup path as an absolute pathname. For example:

install_path\Volmgr\database.

If the backup path contains special characters such as a space (" "), enclose the pathname in quotes ("..."). Use a blank to separate two pathnames, not a comma. The complete list of pathnames to back up must also be enclosed in quotes.

See Example 3.

To back up a NetBackup catalog on a media server other than the master server, specify the catalog backup path as *hostname:pathname*. (This configuration is supported only by NetBackup Enterprise Server.) For example: *hostname:install_path\Volmgr\database.*

If *-nodbpaths* is present, you must specify at least one path.

RETURN VALUES

An exit status of 0 means that the backup ran successfully.

Any exit status other than 0 means that an error occurred.

EXAMPLES

Examples 1 and 2 assume that NetBackup is configured so that bpbackupdb can use the default values for catalogs and destination. Example 3 uses the *path...* option to specify the catalogs to back up.

Example 1

Back up the NetBackup catalogs:

```
bpbackupdb
```

If the backup succeeds, the NetBackup mail administrator receives an email that contains the details of the backup.

If the backup fails, the NetBackup mail administrator receives an email that contains the reason for the failure.

Example 2

Back up the NetBackup catalogs to the tape device: \\.\Tape1.

```
bpbackupdb -tpath \\.\Tape1
```

Assign the catalog backup tape before you run the bpbackupdb command since bpbackupdb does not assign the tape.

Example 3

Back up the catalogs that are specified in the *path...* option in addition to the configured NetBackup catalogs.

```
bpbackupdb "C:\catalog A" "C:\catalog B"
```

MESSAGES

If bpbackupdb succeeds, it logs one of the following messages:

```
NB database backup to path destination SUCCEEDED  
NB database backup to media id destination SUCCEEDED  
NB database backup SUCCEEDED
```

If bpbackupdb fails, it logs one of the following messages:

```
NB database backup to path destination FAILED  
NB database backup to media id destination FAILED  
NB database backup FAILED
```

bpbackupdb also sends mail to the NetBackup administrator who reports the results of the backup.

FILES

```
install_path\NetBackup\db\*  
install_path\NetBackup\logs\admin\log.mmddy  
install_path\Volmgr\database\*
```

SEE ALSO

bprecover

bpcatarc

NAME

bpcatarc - back up the NetBackup catalog

SYNOPSIS

```
install_path\NetBackup\bin\admincmd\bpcatarc [-version] [-help]  
[(-remove_dotf)]
```

DESCRIPTION

bpcatarc processes the output of bpcatlist to back up the selected catalog image .f files and update their image file's catarc field with this backup job ID.

Any authorized user can initiate this command.

For more information about NetBackup authorization, refer to the *NetBackup Security and Encryption Guide*.

OPTIONS

-version

Display the bpcatarc version and exit.

-help

Display the help text.

-remove_dotf

Remove the .f files for an archived image immediately so that it is not necessary to run bpcatrm.

SEE ALSO

bpcatlist, bpcatres, bpcatrm

bpcatlist

NAME

bpcatlist - list selected parts of NetBackup catalog

SYNOPSIS

```
install_path\NetBackup\bin\admincmd\bpcatlist/usr/opensv/netbackup/bin/admincmd/bpcatlist [-server server_name] [-client client_name] [-since ctime | [-since-days nnn | -since-weeks nnn | -since-months nnn | -before-days nnn | -before-weeks nnn | -before-months nnn]] [-before ctime | [-since-days nnn | -since-weeks nnn | -since-months nnn | -before-days nnn | -before-weeks nnn | -before-months nnn]] [-date ctime] [-policy policy_name] [-sched sched_name] [-id backup_id] [-catarc catarc_id] [-version] [-help] [-online | -offline]
```

DESCRIPTION

bpcatlist is the starting point for all catalog archiving operations. Use bpcatlist to select the specific parts of the NetBackup catalog with which you want to work. All files-file (also called image .f files), the largest files in a NetBackup catalog, selected for bpcatarc, bpcatres, or bpcatrm, are first selected with bpcatlist. The output of bpcatlist is piped to the action you want to perform.

OPTIONS

-server *server_name*

Indicates the name of the NetBackup server. Default: *server_name* is the first SERVER name listed in the bp.conf file.

-client *client_name*

Create a list of backup images for *client_name*. Default: *client_name* is CLIENT_NAME in bp.conf or the current host name.

To select all clients, use -client all

-since [*ctime* | [-since-days *nnn* | -since-weeks *nnn* | -since-months *nnn* | -before-days *nnn* | -before-weeks *nnn* | -before-months *nnn*]]

List backup images since the specified time that is expressed in *ctime* (for example, Fri Sep 13 00:00:00 2004).

If no year is specified, bpcatlist uses the current year by default.

The following command lists all images after December 31, 2004:

```
bpcatlist -since 2004
```

Additional examples are found in the following "Examples" section.

```
-before [ctime | [-since-days nnn | -since-weeks nnn | -since-months  
nnn | -before-days nnn | -before-weeks nnn | -before-months  
nnn]
```

List backup images before the specified time that is expressed in *ctime* (for example, `Fri Sep 13 00:00:00 2004`). If no year is specified, `bpcatlist` uses the current year by default. For example:

```
-date ctime
```

List of backup images for the specified date that is expressed in *ctime* (for example, `Fri Sep 13 00:00:00 2004`). If no date is specified, `bpcatlist` uses the current date by default.

Additional examples are found in the following "Examples" section.

```
-catarc catarc_id
```

List the files-file that were archived with the specified *catarc_id*. For example:

```
-catarc 1022754972
```

```
-policy policy_name
```

List the backups that are created by the indicated *policy_name* for the specified client.

```
-sched sched_name
```

List the backups that are created following *schedule_name* for the specified client.

```
-id backup_id
```

Create a list for the specified *backup_id*.

```
-online
```

List only files-file that are online.

```
-offline
```

List only files-file that are offline.

```
-version
```

Display the `bpcatlist` version and exit.

```
-help
```

Display the help text.

EXAMPLES

Displayed dates must be specified in *ctime*(for example, `Fri Sep 13 00:00:00 2004`) date format. Displayed dates may be cut and specified without modification.

To list a backup for a specific date and time, specify:

```
bpcatlist -date Mon Sep 16 14:16:28 2004
```

(When no year is specified, the current year is used by default.)

To list all backups between two dates of the current year, specify the following:

```
bpcatlist -before Mon Sep 10 00:00:00 2004 -since Fri Oct  
4 00:00:00 2004
```

To list the backups that are two to three months old, specify the following:

```
bpcatlist -before-months 2 -since-months 3
```

-since and -before use the following equivalent values:

```
-since-days nnn
```

```
-since-weeks nnn
```

```
-since-months nnn
```

```
-before-days nnn
```

```
-before-weeks nnn
```

```
-before-months nnn
```

For example, the setting `-since-days 14` is equivalent to `-since-weeks 2`

SEE ALSO

bpcatarc, bpcatres, bpcatrm

bpcatres

NAME

bpcatres - restore NetBackup catalog

SYNOPSIS

```
install_path\NetBackup\bin\admincmd\bpcatres [-version] [-help]
```

DESCRIPTION

bpcatres processes the output of bpcatlist to restore the selected catalog image .f files.

Any authorized user can initiate this command.

For more information about NetBackup authorization, refer to the *NetBackup Security and Encryption Guide*.

OPTIONS

- version
Display the bpcatres version and exit.
- help
Display the help text.

SEE ALSO

bpcatarc, bpcatlist, bpcatrm

bpcatrm

NAME

bpcatrm - delete NetBackup catalog

SYNOPSIS

```
install_path\NetBackup\bin\admincmd\bpcatrm [-version] [-help]
```

DESCRIPTION

bpcatrm processes the output of bpcatlist or bpcatarc to delete the selected catalog image .f files that have a valid catarc id in their image file.

Any authorized user can initiate this command.

For more information about NetBackup authorization, refer to the *NetBackup Security and Encryption Guide*.

OPTIONS

-version

Display the bpcatrm version and exit.

-help

Display the help text.

SEE ALSO

bpcatarc, bpcatlist, bpcatres

bpcd

NAME

bpcd - NetBackup client daemon. Enables the NetBackup clients and servers to accept requests from NetBackup servers.

SYNOPSIS

```
install_path\NetBackup\bin\bpcd.exe [-standalone] [-debug] [-portnum  
number] [-keyfile] [-restrict_if host_or_ip]
```

DESCRIPTION

On Windows systems, **bpcd** is a communications daemon that the NetBackup Client Service **bpinetd(1M)** activates. Typically, on UNIX systems **inetd(1M)** activates **bpcd**.

The **bpcd** daemon accepts requests from NetBackup servers. Requests include the following:

- Initiate backup and restore jobs
- Get NetBackup configuration parameters
- Set NetBackup configuration parameters

When you install NetBackup on a Windows client, the installation process adds entries for **bpcd** to `%SystemRoot%\system32\drivers\etc\services`.

The `services` entry looks like the following:

```
bpcd 13782/tcp bpcd
```

The `inetd.conf` entry on UNIX looks like the following:

```
bpcd stream tcp nowait root /usr/opensv/netbackup/bin/bpcd bpcd
```

OPTIONS

`-standalone`

Available only on UNIX clients. Instructs **bpcd** to run continuously rather than started by **inetd**.

`-debug`

Available only on UNIX clients and implies `-standalone`. This option prevents **bpcd** from forking and does not disconnect it from standard input, output, and error.

`-portnum number`

Available only on UNIX clients and implies `-standalone`. Specifies the port number where `bpcd` listens for requests. The default is the `bpcd` entry in: `/etc/services`.

`-restrict_if host_or_ip`

Available only on UNIX clients and implies `-standalone`. Specifies the local network interface that `bpcd` accepts connections from. Default is to accept connections from all local network interfaces. You can specify either a host name or an IP address.

`-keyfile`

Available only on UNIX clients and implies `-standalone`. When `-keyfile` is specified, you are prompted for the NetBackup pass phrase that lets `bpcd` access the NetBackup encryption key file.

See the section "Additional Key File Security (UNIX clients only)" in the *NetBackup Encryption Administrator's Guide* for additional information.

SEE ALSO

`bpclient`, `bpkeyfile`

bpchangeprimary

NAME

`bpchangeprimary` - promote a copy of a backup to be the primary copy

SYNOPSIS

```
install_path\NetBackup\bin\admincmd\bpchangeprimary -copy number | -pool  
volume_pool | -group volume_group [-id backup_id] [-M master_server]
```

```
install_path\NetBackup\bin\admincmd\bpchangeprimary -copy number | -pool  
volume_pool | -group volume_group [-sl schedule_name] [-pn  
policy_name] [-st schedule_type] [-pt policy_type] [-cl client_name]  
[-kw keyword] [-sd date] [-ed date] [-M master_server]
```

DESCRIPTION

The `bpchangeprimary` command lets you change which copy is the primary copy for a set of backup images. You can choose the copy to be promoted to primary by specifying a copy number, volume pool, or volume group. You can apply several optional criteria to identify the backup images to be affected.

The primary copy of a backup is the copy used by a restore process. Ensure that the primary copy is accessible for restore. For instance, if one copy of a backup was sent off site, change the primary copy to be the copy that remains on site.

The `bpchangeprimary` command finds all backups that match the specified criteria, and for those images that it finds, updates their copy number to primary.

If you use the `-copy` option, the specified copy number becomes the primary copy. If you use the `-group` or `-pool` option, the process identifies all media IDs that belong to the specified volume group or volume pool. It then changes all copies that reside on those media to primary.

Any authorized user can initiate this command.

For more information about NetBackup authorization, refer to the *NetBackup Security and Encryption Guide*.

OPTIONS

One of the following three options is required; using one precludes use of the others.

`-copy number`

Specifies that the `copy_number` is the number of the backup copy you want to promote to primary.

`-pool volume_pool`

Specifies that the copy on the media that belongs to `volume_pool` to be promoted to primary.

`-group volume_group`

Specifies that the copy on the media that belongs to `volume_group` to be promoted to primary.

You can apply combinations of one or more of the following criteria to specify which copies are made primary. None of the following options are required.

`-cl client_name`

Specifies that backups of `client_name` are affected. This name must be as it appears in the NetBackup catalog. For those backup images, this option promotes the copy that corresponds to the specified `-pool`, `-group`, or `-copy` option to primary. The default is all clients.

`-sd date`

`-ed date`

Specifies the start date (`-sd`) or end date (`-ed`) of the backup images for which the primary copy is changed.

The default start date is January 1, 1970, which effectively causes a search for all images. If you run `bpchangeprimary` without using the `-sd` option, the following occurs: you are prompted for a confirmation that you want to change the primary copy for the backups that were created after January 1, 1970.

The date format depends on the user's locale setting. See the NOTES section for more information. For the C locale, the date syntax is as follows:

mm/dd/yy [hh[:mm[:ss]]]

The default end date is the current date and time. The valid range of dates is from 01/01/1970 00:00:00 to 01/19/2038 03:14:07.

`-id backup_id`

Specifies the backup ID of the backup image for which the primary copy is changed. For that backup image, `-id backup_id` changes the copy that corresponds to the specified `-pool`, `-group`, or `-copy` option.

If you specify this option, you can specify an alternate master server (using the `-M` option). You must specify one of `-pool`, `-group`, or `-copy`. No other options are used with `-id`.

`-kw keyword`

Specifies a keyword phrase for NetBackup to use when you identify backup images for which the primary copy is changed.

`-M master_server`

Specifies that the backups that belong to *master_server* are affected. For those backup images, `-M master_server` promotes the copy that corresponds to the specified `-pool`, `-group`, or `-copy` option to primary.

If you use this option, any other options you specify determine which backup images on the specified master server are affected. The *master_server* must allow access by the system that issues the `bpchangeprimary` command. The default is the master server for the system that runs the `bpchangeprimary` command.

`-pn policy_name`

Specifies the name of the backup policy of the backups for which the primary copy is changed. The default is all policies.

`-pt policy_type`

Specifies the type of the backup policies of the backups for which the primary copy is changed. The default is all policy types.

The *policy_type* is one of the following character strings:

Informix-On-BAR

MS-Exchange-Server

MS-SQL-Server

MS-Windows

NetWare

Oracle

OS/2

Standard

Sybase

NDMP

The following policy types apply only to NetBackup Enterprise Server:

AFS

Auspex-FastBackup

DataTools-SQL-BackTrack

DB2

FlashBackup

SAP

Split-Mirror

`-sl schedule_name`

Specifies the *schedule name* (label) for the selection of the backup images for which the primary copy is changed.

By default, the `bpchangeprimary` command uses all schedules.

`-st schedule_type`

Specifies the schedule type for the selection of the backup images for which the primary copy is changed.

By default, the `bpchangeprimary` command uses any schedule type. Valid vales are as follows:

FULL (full backup)

INCR (differential-incremental backup)

CINC (cumulative-incremental backup)

UBAK (user backup)

UARC (user archive)

NOT_ARCHIVE (all backups except user archive)

NOTES

The format that you must use for date and time values in NetBackup commands varies according to your locale setting.

If you are uncertain of the NetBackup command requirements for your locale, enter the command with the `-help` option and check the USAGE. For example, the following is the output for the `-sd` and `-ed` options:

```
[-sd mm/dd/yyyy HH:MM:SS] [-ed mm/dd/yyyy HH:MM:SS]
```

Notice the month/day/year and hours:minutes:seconds requirements. These are for a locale setting of C and can be different for other locales.

EXAMPLES

Example 1

The following command promotes all copies on the media that belongs to the volume pool, SUN, created after 08/01/2003 to be the primary copy.

```
bpchangeprimary -pool SUN -sd 08/01/2003
```

Example 2

The following command promotes copy 2 of all backups of client, oak, created after 01/01/2003 to be the primary copy:

```
bpchangeprimary -copy 2 -cl oak -sd 01/01/2003
```

Example 3

The following command promotes copy 4 of all backups that the backup policy, Offsite, created after 08/01/2003 to be the primary copy:

```
bpchangeprimary -copy 4 -pn Offsite -sd 08/01/2003
```

bpclient

NAME

bpclient - manage client entries on a master server

SYNOPSIS

```
install_path\NetBackup\bin\admincmd\bpclient [-All] [-M master_server]
[-l|-L|-H]

install_path\NetBackup\bin\admincmd\bpclient -client client_name [-M
master_server] [-l|-L|-H]

install_path\NetBackup\bin\admincmd\bpclient -client client_name [-M
master_server] {-add | -update} {[-dynamic_address 0|1] [-free_browse
0|1|2] [-list_restore 0|1|2|3] [-max_jobs [1-99] [-current_host
host_name] [-current_ip_addr ip_address] [-current_host host_name
[:ip_address]|:ip_address] [-WOFB_enabled 0|1] [-WOFB_FIM 0|1]
[-WOFB_usage 0|1] [-WOFB_error 0|1] [-connect_options 0|1|2 0|1|2
0|1|2|3]]}

install_path\NetBackup\bin\admincmd\bpclient -client client_name [-M
master_server] -delete
```

DESCRIPTION

The bpclient command describes how a NetBackup server connects to NetBackup clients.

OPTIONS

-add
Add a new client entry.

-All
List all client entries. Only the client entries that are added explicitly using the bpclient command appear.

-client *client_name*
Specifies the name of the client to list or update.

-connect_options 0|1|2 0|1|2 0|1|2|3
First set of arguments, Ports, represent the following:
0 = Reserved Port: Use a reserved port number
1 = Non-reserved Port: Connect to the client's bpcd using a non-reserved port number. If you select this option, enable **Allow Nonreserved Ports** for

the selected client. (See the Universal Settings dialog box under **Host Properties > Clients.**)

2 = Use Default: Use Default is the default. Use the value that the DEFAULT_CONNECT_OPTIONS configuration entry on the server defines.

The second set of arguments, BPCD Connect Back, represent the following:

0 = Random Port: NetBackup randomly chooses a free port in the allowed range to perform the traditional connect-back method.

1 = VNETD port: This method requires no connect-back. The Veritas Network Daemon (vnetd) was designed to enhance firewall efficiency with NetBackup during server-to-server and server-to-client communications.

2 = Use Default: The default option. Use the value that the DEFAULT_CONNECT_OPTIONS configuration entry on the server defines.

The third set of arguments, Daemon Connection Port, represent the following:

0 = Automatic: This option means VNETD is used if possible; otherwise Legacy is used.

1 = Use the VNETD port.

2 = Use the Legacy port number.

3 = Use Default: The default option. Use the value that the DEFAULT_CONNECT_OPTIONS configuration entry on the server defines.

NOTE: If the vnetd Daemon Connection Port is used, the BPCD Connect Back setting is not applicable. If the vnetd Daemon Connection Port is used, non-reserved ports are always used regardless of the value of the Ports setting.

`-current_host host_name[:ip_address]:ip_address`

The host name/IP address of the client. This option is only meaningful in the situation where the option `-dynamic_address 1` is used. Usually, you do not have to enter a `-current_host` value. The client normally contacts the master server to set the host name/IP address.

`-delete`

Delete an existing client entry.

`-dynamic_address 0|1`

0 = The client name is assumed to be a valid host name for the client (default).

1 = The client is assumed to have a dynamic host name (such as DHCP).

`-free_browse 0|1|2`

`-free_browse` is a method that allows users to get around the checking that the server does when it browses images (owner or group). By default,

normal users are not allowed to browse into scheduled backups on Windows.

0 = Allow

1 = Deny

2 = Use

By default, both the client and the server should be set up to 0 (allow). To browse freely, either the client or the server must be set up to 2 (use). Neither can be set up for 1 (deny).

-H

List host specific client information.

-l

Lists the limited client information.

-L

List all client information in a VERBOSE format.

-M *master_server*

Name of the master server that contains the client entries. The first server name in the local configuration is the default master server.

-list_restore 0|1|2|3

-list_restore can be set up on the server to disallow list and restore requests from a particular client. The value in the client database overrides the `bp.conf` file setting.

0 = Not specified (default)

1 = Allow both list and restore requests

2 = Allow list requests only

3 = Deny both list and restore requests

-max_jobs [1-99]

Specify the maximum number of jobs that are allowed to run concurrently on this client, up to 99. You can configure this item in the NetBackup-Java Administration Console. It is labeled "Maximum data streams." To perform this function using this GUI, select the following: Host Properties > Master Servers > (double-click the master server name) > Client Attributes. Then select the client.

-update

Update an existing client entry.

-WOFB_enabled 0|1

0 = disable Windows Open File Backup for the client that is specified in *client_name*.

1 = enable Windows Open File Backup for the client that is specified in *client_name*.

-WOFB_FIM 0|1

0 = Use Volume Snapshot Provider (VSP) as the snapshot provider for the Windows Open File Backups

1 = Use Microsoft's Volume Shadow Service (VSS) as the snapshot provider for Windows Open File Backups

-WOFB_usage 0|1

0 = Individual Drive Snapshot. Specifies that the snapshot be of an individual drive. When this property is enabled, snapshot creation and file backup is done sequentially on a per volume basis.

1 = Global Drive Snapshot. Specifies that the snapshot is of a global drive. The snapshots are taken at one time for all the volumes that require snapshots for the backup job (or stream group for multi-streamed backups).

-WOFB_error 0|1

0=Abort Backup on Error. Specifies that a backup aborts if it fails for a snapshot-related issue in the following situation: after the snapshot is created and while the backup uses the snapshot to back up open or active files on the file system.

1=Disable Snapshot and Continue. Specifies that if the snapshot becomes invalid during a backup, the volume snapshots for the backup are destroyed. The backup continues with Windows Open File Backups disabled.

NOTES

Any authorized user can initiate this command.

For more information about NetBackup authorization, refer to the *NetBackup Security and Encryption Guide*.

bpcIntcmd

NAME

`bpcIntcmd` - test functionality of a NetBackup system and enable fibre transport services on a NetBackup client

SYNOPSIS

```
install_path\bin\bpcIntcmd[sv] [-pn] [-self] [-hn hostname] [-server  
  NBU_master] [-ip ip_address] [-gethostname] [-is_local_host hostname]  
  [-check_vxss] [-check_vxss_with_host hostname] [-get_pbx_port  
  hostname] [-get_remote_host_version hostname] [ -ml | -di ]  
  [-sanclient [0 | 1]]
```

DESCRIPTION

The `bpcIntcmd` command tests the functionality of a NetBackup system and displays information about it. It also enables and disables the fibre transport services on a NetBackup client.

You must have administrative privileges to initiate this command.

OPTIONS

`-check_vxss`

Checks if NBAC is configured correctly on the local system.

`-check_vxss_with_host hostname`

Checks if NBAC is configured correctly on the local system to connect to the remote host, *hostname*.

`-di filename`

Deletes an image by specifying a file name. This option is supported only for OBackup, SQL-BackTrack, and Sybase.

`-gethostname`

Returns the host name that NetBackup uses on the local system.

`-get_pbx_port hostname`

Displays the number that *hostname* considers the PBX port number. If *hostname* is not specified, the option displays the number that the local host considers the PBX port number.

`-get_remote_host_version hostname`

Returns the version of NetBackup that is running on the system that is identified in the *hostname* variable.

- `-hn hostname`
Returns the host name, alias, and IP address information about the host name that is identified in the *hostname* variable.
- `-ip ip_address`
Returns the host name, alias, and IP address information about IP address, *ip_address*.
- `-is_local_host hostname`
Checks if *hostname* is a network interface on the local system.
- `-ml filename`
Displays the media ID by specifying a file name. By specifying a single filename in an image, `-ml filename` returns the media ID of the tape, which contains the image that contains that file.
- `-pn`
Returns what the master server considers your host name (or peer name) to be.
- `-sanclient [0 | 1]`
0 - Disables the client Fibre Transport (FT) service. The command returns a NetBackup SAN client to normal client functionality.
1 - Enables the client FT service, effectively making a regular NetBackup client a SAN client.
- `-self`
Returns the information about the local system.
- `-server NBU_master`
Returns the host name information of the NetBackup master server.
- `-sv`
Returns the NetBackup version of the master server.

SEE ALSO

`bpnbat`

bpcompatd

NAME

bpcompatd - run NetBackup compatibility service

SYNOPSIS

```
install_path\NetBackup\bin\bpcompatd [-max_time seconds] [-console]
    [-debug]
install_path\NetBackup\bin\bpcompatd -help [-debug]
install_path\NetBackup\bin\bpcompatd -alive [-debug]
install_path\NetBackup\bin\bpcompatd -terminate [-debug]
install_path\NetBackup\bin\bpcompatd -bpcd_connect clientname [-debug]
install_path\NetBackup\bin\bpcompatd -vmd_connect hostname [-debug]
install_path\NetBackup\bin\bpcompatd -robot_connect hostname robot_type
    [-debug]
install_path\NetBackup\bin\bpcompatd -bpjobd_connect hostname [-debug]
install_path\NetBackup\bin\bpcompatd -bpdbm_connect hostname [-debug]
install_path\NetBackup\bin\bpcompatd -bprd_connect hostname [-debug]
```

DESCRIPTION

This command is used internally by new NetBackup services to communicate with legacy NetBackup services.

OPTIONS

-help
Displays the options available with the bpcompatd command.

-alive
Tests the local bpcompatd daemon or service to see if it is running.

-terminate
Terminates the local bpcompatd daemon or service if it is running.

-bpcd_connect *clientname*
Tests a bpcd connection to *clientname* using the bpcompatd command.

-vmd_connect *hostname*
Tests a vmd connection to *hostname* using the bpcompatd command.

`-robot_connect hostname`

Tests a robot daemon connection to *hostname* for robot type <robot_type> using the `bpcompatd`.

`-bpjobd_connect hostname`

Tests a `bpjobd` connection to *hostname* using the `bpcompatd` command.

`-bpdbm_connect hostname`

Test a `bpdbm` connection to *hostname* using the `bpcompatd` command.

`-bprd_connect hostname`

Test a `bprd` connection to *hostname* using the `bpcompatd` command.

If you specify `-debug`, the information that is normally logged in the debug log file of `bpcompatd` is written to standard error.

If you do not specify one of the these options, `bpcompatd` runs as a daemon (for UNIX/Linux) or a service (for Windows). The following options are available when you run `bpcompatd` as a daemon or service:

`-max_time seconds`

The maximum time `bpcompatd` waits for a new connection before performing routine tasks. The default is 60 seconds for UNIX/Linux and 1 second for Windows.

`-console`

This option is applicable to Windows only. Normally, `bpcompatd` is run through the Service Manager. You can use the `-console` option to run the `bpcompatd` service from the command line.

`-debug`

If you specify `-debug`, the information that normally is logged in the debug log file of `bpcompatd` is written to standard error. For Windows, this option implies the `-console` option. For UNIX/Linux, this option prevents the `bpcompatd` service from running in the background.

bpconfig

NAME

`bpconfig` - modify or display global configuration attributes for NetBackup

SYNOPSIS

```
install_path\NetBackup\bin\admincmd\bpconfig [-cd seconds] [-ha hours]  
[-kl days] [-kt days] [-ma [address]] [-mdtm drives] [-sto seconds]  
[-mj number] [-period hours] [-prep hours] [-to seconds] [-max_copies  
number] [cleanup_int hours] [-tries times] [-wi minutes] [-pui  
minutes] [-v] [-M master_server,...]  
  
install_path\NetBackup\bin\admincmd\bpconfig [-L | -l | -U [-v] [-M  
master_server,...]]
```

DESCRIPTION

The `bpconfig` command modifies or displays the NetBackup global configuration attributes. These attributes affect operations for all policies and clients. With the exception of the NetBackup administrator's email address, the default values for these attributes are adequate for most installations.

See the NetBackup Global Attributes section in the *NetBackup Administrator's Guide*, which describes the implications of setting the attribute values.

- The first form of `bpconfig` modifies one or more of the NetBackup global configuration attributes. At least one option that changes a NetBackup global configuration attribute must be on the command line.
- The second form of `bpconfig` displays the current settings of the NetBackup global configuration attributes. See the section DISPLAY FORMATS for more detail.

Errors are sent to `stderr`. A log of the command's activity is sent to the NetBackup admin log file for the current day.

Any authorized user can initiate this command.

For more information about NetBackup authorization, refer to the *NetBackup Security and Encryption Guide*.

OPTIONS

`-cd seconds`

The number of seconds that is the Compress-image-Database time interval. When *seconds* is a positive integer, an image compresses after this

number of seconds that elapsed since the creation of the image. The range of values is 86400 to 2147472000. On Windows, NetBackup uses NTFS file compression only if the database is in an NTFS partition. Otherwise, it is not compressed.

The effect of compression is that the image database needs less disk space. However, when you browse the image database for restoring, decompress the images before you search for them. If you browse for a restore, the compressed images are not found. To decompress the images, you must use the `bpimage` command.

The default is 0, which means no compression is done.

`-cleanup_int hours`

Specifies the interval (in hours) between image database cleanup operations. The default value is 12 (hours). Since cleanup cannot run during a catalog backup, large 24x7 environments that run long catalog backups may need a shorter cleanup interval (e.g., 3 hours). Regardless of the value of this option, the image database is automatically cleaned up at the end of a session of scheduled backups.

`-mdtm drives`

The maximum drives for this master and remote media server cluster that the master server should consider available when it schedules backups. An appropriate value for this attribute is the physical number of drives. This number counts shared drives only once in the master and the media server cluster. *drives* must be less than or equal to the number that the NetBackup version that is installed on the server allows. (This number is 2 for NetBackup Server and unlimited for NetBackup Enterprise Server.) *drives* is a non-negative integer. The default is 0 (unlimited).

`-ha hours`

The number of *hours* ago that is the beginning of the time range for selecting NetBackup report entries. The end of the time range is the current time.

For instance, if *hours* ago is 24 and if you request a Backup Status report at 10:00 a.m., the report includes all backups that ran from 10:00 a.m. yesterday until 10:00 a.m. today.

This value is used to calculate the time range for general reports and media reports. General reports include Backup Status, Client Backups, Problems, and All Log Entries. Media reports include Media List, Media Summary, Media Contents, Images on Media, and Media Log Entries.

Hours Ago is a positive integer in the range of 1 to 32767. The default value is 24 (hours).

`-kl` *days*

The number of days to keep logs. This number determines how long the NetBackup master server keeps its Error database and debug logs. NetBackup derives its Backup Status, Problems, All Log Entries, and Media Log Entries reports from the Error database.

This value limits the period that these reports can cover. The range of values is 1 to 32767. The default is 28 days. A value of zero (0) turns logs off.

Note: This attribute has no effect on remote media servers or clients (remote media servers apply only to NetBackup Enterprise Server).

`-kt` *days*

The number of days to Keep True-image-recovery (TIR) data. This value determines how long to keep TIR information for those policies that specify the collection of TIR information. The default is 1 day. A value of zero (0) turns off the TIR information.

`-L`

The list type is long. See the section DISPLAY FORMATS for more detail.

`-l`

The list type is short. This option is the default if the command line has no list-type option (for instance, if you enter `bpconfig` and a carriage return). See the section DISPLAY FORMATS for more detail.

`-M` *master_server, . . .*

`-ma` [*address*]

The mail address for the NetBackup administrator. NetBackup sends notification of failed automatic backups, the manual backup operations that the administrator directs, and automatic database backups to this email address. The default is NULL (no email address).

If no address is provided, the current setting of the Admin Mail Address is cleared. Notification is no longer sent by email to the NetBackup administrator.

`-max_copies` *number*

Specify the maximum number of copies per backup. The range of values is 2 to 10. The default value is 2.

`-sto` *seconds*

The multihomed-media-mount timeout. This timeout is the time in seconds that NetBackup waits for a shared medium to be mounted, positioned, and ready on backups and restores. Use this timeout to eliminate excessive waits if another server uses a shared medium. The default is 0, which means no timeout (unlimited wait time).

`-mj number`

Specifies the maximum jobs per client. This number is the maximum number of jobs that a client can perform concurrently. It must be a positive integer. The range values is 1 to 32767. The default value is 1.

`-period hours`

The time interval that is associated with the configured number of tries for a backup (see `-tries`). This interval is the period in hours during which NetBackup attempts a backup job for a client/policy/schedule combination for as many tries as configured. The hours must be a positive integer. The range values is 1 to 24. The default value is 12 hours.

Note: This attribute does not apply to user-directed backups and archives.

`-prep hours`

The preprocessing interval. This interval is the minimum time in hours between client queries to discover new paths when NetBackup uses auto-discover-streaming mode.

For additional information, see "Setting the Preprocess Interval for Auto Discovery" in the File-List Directives for Multiple Data Streams in the *NetBackup Administrator's Guide*.

The default Preprocess Interval value is 4 hours. If the preprocessing interval changes, change it back to the default by specifying `-prep -1`.

The preprocessing interval can be set to preprocess immediately by specifying 0 as the preprocess interval for auto discovery on the `bpconfig` command line.

The maximum Preprocessing Interval is 48 hours.

`-to seconds`

The media-mount timeout. This timeout is the time in seconds that NetBackup waits for the requested media to be mounted, positioned, and ready on backups and restores. Use this timeout to eliminate excessive waits when you need to mount media manually (for example, when robotic media is out of the robot or off site).

The default is 0, which means no timeout (unlimited wait time). If seconds is not 0, its value must be 300 (5 minutes) or greater.

`-tries times`

The number of retries for a backup, during the configured time period (see `-period`). NetBackup tries to run a backup job for a given client/policy/schedule combination the specified number of times in the configured period. This option lets you to limit the number of backup attempts if repeated failures occur.

Note: This attribute does not apply to user-directed backups and archives.

Values for `-tries` range from 1 to 32767. The default is 2 tries. If defaults are used for both `-tries` and `-period`, NetBackup attempts the backup 2 times in 12 hours.

`-U`

The list type is user. See the section DISPLAY FORMATS for more detail.

`-v`

Selects verbose mode for logging. This option is meaningful only if it runs with the debug log function on (the `install_path\NetBackup\logs\admin` directory is defined).

`-wi minutes`

Job Retry Delay. Specifies how often NetBackup retries a job. The default value is 10 minutes. The range of values is 1 to 1440 (minutes).

`-pui minutes`

Policy Update Interval. Specifies how often NetBackup policy updates are processed. The default value is 10 minutes. The range of values is 1 to 1440 (minutes).

DISPLAY FORMATS

`bpconfig` uses three different formats to display the current values of the NetBackup global configuration attributes.

■ User Display Format (`-U`)

If the command line contains `-U`, the display format is user. The user display format is the format used by `bpadm` and the NetBackup graphical-user interfaces. This option produces a list with one global attribute per line. Each line has the form *global attribute descriptor: value*. This list is similar to the `-L` format, except that the global attribute descriptors are more explicit.

The fields are as follows:

- Admin Mail Address
- Job Retry Delay
- Max Simultaneous Jobs/Client
- Backup Tries (x tries in y hours)
- Keep Error/Debug Logs
- Max drives this master
- Keep TrueImageRecovery Info
- Compress Image DB Files
- Maximum Backup Copies

Media Mount Timeout
 Display Reports
 Preprocess Interval

■ Long Format (-L)

If the command line contains -L, the display format is long. This option produces a list with one global attribute per line, in the format *global attribute descriptor: value*. The fields are as follows:

Mail Admin
 Job Retry Delay
 Max Jobs/Client
 Backup Tries
 Keep Logs
 Max drives/master
 Compress DB Files
 Media Mnt Timeout
 Display Reports
 Keep TIR Info
 Prep Interval
 Max Backup Copies
 DB Clean Interval
 Policy Update Interval

■ Short Format (-l)

If the `bpconfig` command line contains -l or contains no list-format option, the display format is short, which produces a terse listing. This option is useful for the scripts or the programs that rework the list into a customized report format. The list layout is a single line that contains the values for all global attributes. The time units follow the attributes in parentheses for the attributes that are expressed in units of time. The attributes appear in the following order with blanks between them:

NetBackup administrator email address
 Job Retry Delay (minutes)
 Time period (hours)
 Maximum simultaneous jobs per client
 Tries per period
 Keep logs (days)
 Maximum drives this master
 Compress image database interval (seconds; 0 denotes no compression)
 Media mount timeout (seconds; 0 denotes unlimited)
 Multihosted-media-mount timeout (seconds; 0 denotes unlimited)
 Postprocess images flag (0 denotes deferred, otherwise immediately)

Display reports from <x> hours ago (hours)

Keep TIR information (days)

Preprocessing interval (hours)

Example of how the display formats differ:

bpconfig runs with each of the three display formats on a NetBackup installation. The NetBackup global attributes are the same for the three displays.

The first display format, -U, looks like the following:

```
bpconfig -U
Admin Mail Address:
Job Retry Delay:          1 minutes
Max Simultaneous Jobs/Client: 1
Backup Tries:            2 time(s) in 12 hour(s)
Keep Error/Debug Logs:  28 days
Max drives this master:  0
Keep TrueImageRecovery Info: 1 days
Compress Image DB Files: (not enabled)
Media Mount Timeout:     0 minutes (unlimited)
Display Reports:         24 hours ago
Preprocess Interval:     0 hours
Maximum Backup Copies:   10
```

The second display format, -L, looks like the following:

```
bpconfig -L
Mail Admin:              *NULL*
Job Retry Delay:        1 minutes
Max Jobs/Client:        1
Backup Tries:           2 in 12 hours
Keep Logs:              28 days
Max drives/master:      0
Compress DB Files:      (not enabled)
Media Mnt Timeout:     0 minutes (unlimited)
Postprocess Image:      immediately
Display Reports:        24 hours ago
Keep TIR Info:          1 days
Prep Interval:          0 hours
Maximum Backup Copies: 10
```

The third display format, -l, looks like the following:

```
bpconfig -l
*NULL* 1 12 1 2 28 0 0 0 0 1 24 1 0
```

The display fields for the -l display are interpreted as follows:

NetBackup administrator email address has not been set

Job Retry Delay is 1 minute

Time period is 12 hours

Maximum simultaneous jobs per client is 1

Tries per period is 2

Keep logs for 28 days

Maximum drives this master is 0
Compress image database interval is 0 seconds; 0 denotes no compression
Media mount timeout is 0seconds; 0 denotes unlimited
Multihosted-media-mount timeout is 0 seconds; 0 denotes unlimited
Postprocess images flag is 1 (immediate)
Display reports from 24 hours ago
Keep TIR information for 1 day
Preprocessing interval is 0 hours

RETURN VALUES

An exit status of 0 means that the command ran successfully.

Any exit status other than 0 means that an error occurred.

If the administrative log function is enabled, the exit status is logged in the administrative daily log under the directory

install_path\NetBackup\logs\admin in the form:

```
bpconfig: EXIT status = exit status
```

If an error occurred, a diagnostic precedes this message.

EXAMPLES

Example 1

While the master server kiwi runs, display the global attribute settings on the master server plim:

```
bpconfig -U -M plim
```

```
Admin Mail Address:          ichabod@null.null.com
Job Retry Delay:             10 minutes
Max Simultaneous Jobs/Client: 1
Backup Tries:                1 time(s) in 8 hour(s)
Keep Error/Debug Logs:      6 days
Max drives this master:     0
Keep TrueImageRecovery Info: 1 days
Compress Image DB Files:    (not enabled)
Media Mount Timeout:        30 minutes
Display Reports:            24 hours ago
Preprocess Interval:        0 hours
Maximum Backup Copies:      10
Image DB Cleanup Interval:  12 hours
Policy Update Interval:     10 minutes
```

Example 2

Set the Compress-image-database interval to 604800 seconds, so that NetBackup compresses images more than 7 days old:

```
bpconfig -cd 604800  
bpconfig -U
```

```
Admin Mail Address:  
Job Retry Delay:          10 minutes  
Max Simultaneous Jobs/Client: 1  
Backup Tries:            2 time(s) in 12 hour(s)  
Keep Error/Debug Logs:  28 days  
Max drives this master:  0  
Keep TrueImageRecovery Info: 2 days  
Compress Image DB Files: older than 7 day(s)  
Media Mount Timeout:    0 minutes (unlimited)  
Display Reports:        24 hours ago  
Preprocess Interval:    0 hours  
Maximum Backup Copies:  10  
Image DB Cleanup Interval: 12 hours  
Policy Update Interval: 10 minutes
```

Example 3

Set the Media Mount Timeout to 1800 seconds.

```
bpconfig -to 1800  
bpconfig -U
```

```
Admin Mail Address:      sasquatch@wapati.edu  
Job Retry Delay:        10 minutes  
Max Simultaneous Jobs/Client: 1  
Backup Tries:           1 time(s) in 12 hour(s)  
Keep Error/Debug Logs:  3 days  
Max drives this master:  0  
Keep TrueImageRecovery Info: 24 days  
Compress Image DB Files: (not enabled)  
Media Mount Timeout:    30 minutes  
Display Reports:        24 hours ago  
Preprocess Interval:    0 hours  
Maximum Backup Copies:  10  
Image DB Cleanup Interval: 12 hours  
Policy Update Interval: 10 minutes
```

FILES

```
install_path\NetBackup\logs\admin\  
install_path\NetBackup\db\config\behavior
```

SEE ALSO

bpimage

See the *NetBackup Administrator's Guide* for information on Multi Hosted Drives.

bpdjobs

NAME

bpdjobs - interact with NetBackup jobs database

SYNOPSIS

```
install_path\NetBackup\bin\admincmd\bpdjobs [-report] [-M
  master_servers] [-ignore_parent_jobs] [ -vault | -lvault |
  -all_columns | -most_columns | -gdm ] [-file pathname] [-append]
  [-noheader] [-mastertime] [-jobid job1,job2,...jobn] [verbose]

install_path\NetBackup\bin\admincmd\bpdjobs -summary [-M master_servers]
  [-ignore_parent_jobs] [ -U | -L | -all_columns ] [-file pathname]
  [-append] [verbose]

install_path\NetBackup\bin\admincmd\bpdjobs -resume | -suspend | -delete
  | -cancel | -restart job1,job2,...jobn | type=jobtype | type=all [-M
  master_servers] [-quiet]

install_path\NetBackup\bin\admincmd\bpdjobs -cancel_all [-M
  master_servers]

install_path\NetBackup\bin\admincmd\bpdjobs -clean [-M master_servers]
  [-keep_hours hours] or [-keep_days days] [-keep_successful_hours
  hours] or -keep_successful_days days] [verbose]

install_path\NetBackup\bin\admincmd\bpdjobs -version

install_path\NetBackup\bin\admincmd\bpdjobs -help
```

DESCRIPTION

bpdjobs interacts with the jobs database and is useful in scripts or as a command line administration tool. Use bpdjobs to print the entire jobs database, print a summary of the database, delete done jobs, cancel uncompleted jobs, and clean old jobs.

To customize the output of bpdjobs, add column definition entries (BPDBJOBS_COLDEFS) in the bp.conf file.

Refer to the *NetBackup Administrator's Guide for UNIX and Linux, Volume II* for more information about the following: the bp.conf file and a complete list of the definitions and the BPDBJOBS_COLDEFS entries.

Any authorized user can initiate this command.

For more information about NetBackup authorization, refer to the *NetBackup Security and Encryption Guide*.

The `-cancel`, `-delete`, `-jobid`, `-resume`, and `-suspend` options all use the *jobtype* as a suboption. Enter one of the following as *jobtype*. (Letters following the capitalized letters are ignored.)

```
ALL | *
REStore
BACkup
ARChive
VERify
DUPLICATE
IMPort
LABel
ERAsE
VAULt
TPReq
CLEan
FORmat
INVenTory
QUALification
DBbackup | CATalogbackup
```

OPTIONS

`-all_columns`

Displays all columns of a report or summary. Some of the more useful fields of this command are:

`field2 = jobtype`

0=backup, 1=archive, 2=restore, 3=verify, 4=duplicate, 5=import, 6=catalog backup, 7=vault, 8=label, 9=erase, 10=tape request, 11=clean, 12=format tape, 13=physical inventory, 14=qualification

`field3 = state`

0=queued, 1=active, 2=wait for retry, 3=done

`field5 = policy`

The policy that this job is associated with.

`field6 = schedule`

The schedule that this job is associated with.

`field14 = operation`

0=mount

1=position

2=connect
 3=write
 4=vault initialize
 5=vault duplication
 6=vault duplication complete
 7=vault catalog backup
 8=vault eject
 10=report
 11=duplicate
 12=import
 13=verify
 14=restore
 15=catalog-backup
 16=vault
 17=label
 18=erase
 field21 = subtype
 0=immediate, 1=scheduled, 2=user-initiated, 3=quick erase, 4=long erase
 field23 = schedule_type
 0=full, 1=incr, 2=user backup, 3=user archive, 4=cumulative-incr
 field24 = priority
 The priority that is assigned to this job, as configured in the policy attributes.

The output of this command consists of a single line per backup job. Each line of the output is a comma-delimited list in the following format:

```

jobid,jobtype,state,status,policy,schedule,client,server,started,elapsed,ended,stime,try,operation,kbytes,files,pathlastwritten,percent,jobpid,owner,subtype,classtype,schedule_type,priority,group,masterserver,retentionunits,retentionperiod,compression,kbyteslastwritten,fileslastwritten,filelistcount,[files]...,trycount,[trypid,trystime,tryserver,trystarted,tryelapsed,tryended,trystatus,trystatusdescription,trystatuscount,[trystatuslines]...,trybyteswritten,tryfileswritten]...parentjob,kbpersec,copy,robot,vault,profile,session,ejecttapes,srcstime,srcserver,srcmedia,dstmedia,stream,suspendable,resumable,restartable,databovement,snapshot,backupid,killable,controllinghost
  
```

The following is an example:

```
* 415,Backup,Done,96,jvlcc,vlcdiff,mule,buffalo,0885942000,0000000014,
0885942014,8mm,3,,,,,11602,root,1,0,1,10,,buffalo,2,1,0,0,3,/home/vlc/
jadm_JAVA/usr/opencv/java,/home/vlc/directory with spaces,/home/vlc/test,3,
11544,8mm,buffalo,885941970,13,885941983,96,unable to allocate new media
for backup\, storage unit has none available,2,01/27/98 16:59:30 - connecting,
01/27/98 16:59:30 - connected; connect time: 000:00:00,0,0,11573,8mm,buffalo,
885941986,11,885941997,96,unable to allocate new media for backup\, storage
unit has none available,2,01/27/98 16:59:40 - connecting,01/27/98 16:59:40 -
connected; connect time: 000:00:00,0,0,11602,8mm,buffalo,885942000,14,
885942014,96,unable to allocate new media for backup\, storage unit has none
available,2,01/27/98 17:00:00 - connecting,01/27/98 17:00:00 - connected;
connect time: 000:00:00,0,0
```

Refer to Example 1 for an example on how to interpret the `-all_columns` output.

`-append`

Appends the output to the file that the `-file` option specifies. If no `-file` option is provided, the output goes to `stdout`.

`-cancel job1,job2,...jobn |type=jobtype|type=all`

Causes `bpdjobs` to cancel active jobs cleanly that appear with a Status 150 in the Activity Monitor. For example:

```
bpdjobs -cancel 11328
```

```
bpdjobs -cancel 11328,11329,11330
```

Possible `jobtype` values are listed in the Description section.

`-cancel_all`

Causes `bpdjobs` to cancel cleanly all incomplete jobs that appear with a Status 150 in the Activity Monitor. For example:

```
bpdjobs -cancel_all
```

`-clean`

Causes `bpdjobs` to delete the completed jobs that are older than a specified time period. Use with the `-keep_hours` or `-keep_days`, or `-keep_successful_hours` or `-keep_successful_days` parameters to specify a retention period. For example,

```
bpdjobs -clean -keep_hours 30
```

`-delete job1,job2,...jobn |type=jobtype|type=all`

Deletes the completed jobs that appear in the Activity Monitor. Multiple jobids can be deleted in one command. For example:

```
bpdjobs -delete 11328,11329,11330
```

This option also deletes the following:

- The jobs that `job1,job2,...jobn` specify

- All the eligible jobs that *jobtype* indicates
- All eligible jobs if *type=all* is specified

Possible *jobtype* values are listed in the Description section.

`-file pathname`

Names a file to which the output of `bpdjobs` is written. If no `-file` option is provided, the output goes to `stdout`.

`-gdm`

Displays less of the information in a report than `-most_columns`.

`-help`

Prints a command line usage message when `-help` is the only option on the command line.

`-ignore_parent_jobs`

Ignores the parent jobs for the `-report` and `-summary` options.

`-jobid job1,job2,...jobn |type=jobtype|type=all`

Reports on multiple job IDs.

Possible *jobtype* values are listed in the Description section.

`-keep_days days`

Used with the `-clean` option to specify how many days `bpdjobs` keeps completed jobs. Default is 3 days.

`-keep_hours hours`

Used with the `-clean` option to specify how many hours `bpdjobs` keeps completed jobs. Default is 72 hours.

`-keep_successful_days days`

Used with the `-clean` option to specify how many days `bpdjobs` keeps successful completed jobs. Default is 3 days.

This value must be less than the `-keep_days` value.

`-keep_successful_hours hours`

Used with the `-clean` option to specify how many hours `bpdjobs` keeps successful completed jobs. Default is 72 hours.

This value must be less than the `-keep_hours` value.

`-L`

Reports in long format.

`-lvault`

Displays the additional columns specific to Vault jobs.

`-M master_servers`

Applies to an environment with multiple master servers. Use the `-M` option to summarize jobs, delete jobid(s), cancel jobid(s), and cancel all active job IDS for a specific master server:

`-mastertime`

By default, `bpdjobs` translates the start or the end times to be relative to the local clock. A job that starts 10 minutes ago looks like it starts 10 minutes ago regardless of time zone and clock differences with the master server. This option, however, circumvents that translation so that time values are consistent between admin clients.

`-most_columns`

Behaves similarly to `-all_columns` but does not print the file list or any information on previous attempts. The `-most_columns` option is significantly faster than `-all_columns`.

`-noheader`

Prevents the header from being printed in the report.

`-quiet`

Cancels the reporting of the number of jobs resumed/suspended/deleted/canceled.

`-report`

Provides a report of data that is stored in the Activity Monitor. If no option is specified with `bpdjobs`, `-report` is the default option.

`-restart job1,job2,...jobn |type=jobtype|type=all`

Cleanly restarts a job that `jobtype` indicates. This option supports backups and enables you to restart a job by typing the word BACKup in the Activity Monitor.

`-resume job1,job2,...jobn |type=jobtype|type=all`

Resumes the jobs that `job1, job2, ... jobn` specify, all eligible checkpoint backups or restore the jobs that `jobtype` indicates, or all eligible jobs if `type=all` is specified.

Possible `jobtype` values are listed in the Description section.

`-summary [-U | -L | -all_columns]`

Prints a summary line to `stdout` for all the jobs that are stored in `NBU/jobs`.

Parameters `-U` and `-L` format the output of the command. Use the `-file` option to write the output to a given directory or filename. For example:

```
bpdjobs -summary -U -file /tmp/summary.out
```

`-suspend job1,job2,...jobn |type=jobtype|type=all`

Suspends the jobs that *job1, job2, . . . jobn* specifies or all eligible checkpoint backups or restore the jobs that *jobtype* indicates, or all eligible jobs if *type=all* is specified.

Possible *jobtype* values are listed in the Description section.

`-U`

Reports in user format. NetBackup report-generating tools such as the NetBackup-Java Reports application uses this report format.

`-vault`

Displays the additional columns specific to Vault jobs.

`-verbose`

Causes `bpdjobs` to log additional information in the debug log in the following directory, if the directory exists:

`install_path\NetBackup\logs\bpdjobs*`

`-version`

Prints the version string, then halts. Any other switches are ignored.

EXAMPLES

This example shows the following: sample logic to decode `-all_columns` output to produce the backup initiation time of a job that succeeded, but not on the first try.

Field 9 = start time (The time the job was first queued.)

This time is of little value unless you want to know when the job was queued.

Up to Field 32, all fields are fixed. Then Field 32 tells you how many entries are in the filelist fields.

Field 32 = filelistcount (The number of files that are listed in the filelist.)

Add that value to 33 to determine the field that shows the number of tries:

Field 33 + filelistcount = trycount (The number of tries that occurred.)

If there is only one try, calculate the following to determine its start time:

Field 33 + filelistcount + 4 = [first]trystarted (The start time of the first try.)

If there are two tries, go past the status entries. First, calculate the number of entries in the status field:

Field 33 + filelistcount + 9 = trystatuscount (The number of status entries in the first try.)

Then, to get the start time of the second try, calculate the following:

Field 33 + filelistcount + 9 + trystatuscount + 6 = [second]trystarted

FILES

install_path\NetBackup\logs\bpdjobs*

bpdbm

NAME

bpdbm - run NetBackup database manager daemon

SYNOPSIS

```
install_path\NetBackup\bin\bpdbm [consistency [-move]] [converti2] [ctime  
timestamp] [-terminate] [-alive] [-verbose -logqueries -wakeuptime  
minutes]
```

DESCRIPTION

bpdbm responds to the queries that are related to the NetBackup internal databases, which are called catalogs. bpdbm must be running in order for NetBackup commands and utilities to work properly. This daemon runs only on the master server and can be started only by the administrator.

The NetBackup request daemon, bprd, starts bpdbm. You also can start it with the `/usr/openv/netbackup/bin/initbpdbm` script.

When bpdbm starts, the following occurs:

- 1 bpdbm logs a message that indicates it has started, and then verifies that no other instance of bpdbm is running. If another bpdbm process is found, the program terminates.
- 2 bpdbm finds its port number by checking the `services` file for an entry with a service name of bpdbm and a protocol name of tcp. For example:
bpdbm 13721/tcp
- 3 After it binds to its port, bpdbm starts to respond to queries from bprd and the NetBackup administrative utilities. A child process is created to respond to each query.

Any authorized user can initiate this command.

For more information about NetBackup authorization, refer to the *NetBackup Security and Encryption Guide*.

OPTIONS

-alive

Sends a query to bpdbm to determine if the bpdbm service is up.

`-consistency [0-2]`

Runs the consistency checks on the catalog. The following are the three consistency levels:

0 - A quick check of the NetBackup image database (the default).

1 - Performs more checks than the default check.

2 - The most in-depth consistency check. In addition to the checks of levels 0 and 1, this level also checks that the media that is mentioned in the image exists. (In other words, it also cross references the media servers databases.)

On a large NetBackup installation, the process takes much longer to complete than the other checks.

`-converti2`

Converts the old catalogs that were created by using the old directory name scheme without the time-stamp subdirectories for each client to the new scheme. Use caution on this operation and make sure that a valid catalog backup is in hand and ready to use to recover the catalog.

`-ctime timestamp`

Converts a UNIX time stamp to human-readable form.

`-logqueries`

Causes bpdbm to log each bpdbm query to the file `/tmp/BPDBMqueries`. Each query has two entries in the log, one at the start of the query of the form:

```
date_stamp process_id query type
```

and one at the end of the query of the form:

```
date_stamp process_id query type status status
```

where *date_stamp* is a 10-digit integer, *process_id* is the identifier for the process running the query, *type* is an integer that identifies the type of query, and *status* is the status returned by the query.

`-terminate`

Terminates bpdbm. Any currently running child process continues to run until its task is complete.

`-verbose -logqueries`

Causes bpdbm to operate at verbose level 1 if it is configured to run in `bp.conf` at verbose level 0. Also causes the bpdbm log directory and file to be created.

`-wakeupt minutes`

Overrides the default timeout interval (in minutes) that bpdbm uses when it establishes the initial connection on the port. Used on Unix and Linux platforms only.

FILES

```
/usr/opensv/netbackup/db/*  
/usr/opensv/netbackup/bp.conf  
/usr/opensv/netbackup/logs/bpdbm/*  
/usr/opensv/netbackup/bin/initbpdbm
```

SEE ALSO

bpadm, bprd

bpdwn

NAME

bpdwn - shut down NetBackup services on Windows systems

SYNOPSIS

```
install_path\NetBackup\bin\bpdwn [-h] [-S|v] [-f] [-a] [-c] [-d] [-m]  
[-n] [-s] [-r]
```

DESCRIPTION

bpdwn shuts down the NetBackup services including many components of the product, such as the NetBackup databases, Media Manager, clients, and some robotic control daemons. This option does not shut down the processes.

OPTIONS

- h
This option displays the help screen.
- S
This option selects the silent mode. No listing is generated and no confirmation is requested.
- v
The selected verbose mode generates a detailed listing.
- f
This option forces a shutdown of the NetBackup services without prompting the user for a confirmation.
- c
This option shuts down the client.
- d
This option shuts down the NetBackup database.
- m
This option shuts down Media Manager.
- n
This option shuts down the NetBackup server and not the client.
- s
This option shuts down the server (NetBackup and Media Manager).

-r

This option shuts down the robotic control daemons.

SEE ALSO

bpu

bpduplicate

NAME

bpduplicate - create a copy of backups that NetBackup has created

SYNOPSIS

```
install_path\NetBackup\bin\admincmd\bpduplicate -npc new_primary_copy
-backupid backup_id [-local] [-client name]

install_path\NetBackup\bin\admincmd\bpduplicate [-number_copies number]
[-dstunit destination_storage_unit_label [,copy2,...,copyn] [-dp
destination_volume_pool_name [,copy2,...,copyn] [-p | -pb | -PD | -PM]
[-Bidfile file_name] [-v] [-local] [-client name] [-st sched_type]
[-sl sched_label] [-L output_file [-en]] [-shost source_host] [-policy
name] [-s date] [-e date] [-pt policy_type] [-hoursago hours] [[-cn
copy_number] | [-primary]] [-M master_server] [-altreadhost hostname]
[-backupid backup_id] [-id media_id] [-rl
retention_level[,rl-copy2,...,rl-copyn]] [-fail_on_error
0|1[,...,0|1]] [-mpx] [-priority number] [-set_primary_copy_index]
[-owner media_share_grp[,share_group_copy2,... share_group_copyn]]
```

DESCRIPTION

The `bpduplicate` command allows a copy of a backup to be created. The `bpduplicate` command can also change the primary copy in order to enable restoring from a duplicated backup. The primary copy is used to satisfy restore requests and is initially the original copy.

Multiplexed duplications can be created by using the `-mpx` option. Refer to the discussion of the `-mpx` option for more information.

The duplicated backup has a separate expiration date from the original. Initially, the expiration date of the copy is set to the expiration date of the original. You can change the expiration date of the copy or the original by using the `bpexpire` command.

Use `bpduplicate` to create up to 10 copies of unexpired backups.

Authorized users can execute this command.

For more information about NetBackup authorization, refer to the *NetBackup Security and Encryption Guide*.

OPTIONS

- `-altreadhost hostname`
Specify an alternate host from which to read the media. The default condition is that `bpduplicate` reads the source media from the host that performed the backup.
- `-backupid backup_id`
Specifies the backup ID of a single backup to duplicate or for which to change the primary copy.
- `-Bidfile file_name`
file_name specifies a file that contains a list of backup IDs to be duplicated. List one backup ID per line in the file. If this parameter is specified, other selection criteria is ignored.
In addition, the file that is specified with the `-Bidfile` parameter is removed during the execution of that command line interface (CLI). This action happens because the NetBackup GUIs commonly use this parameter. They expect the command-line interface to remove the temporary file that was used for the `-Bidfile` option upon completion. Direct command-line interface users can also use the option; however, it removes the file.
- `-client name`
Specifies the name of the client that produced the originals and is used as search criteria for backups to duplicate. The default is all clients.
When you specify `-client` with the `-npc` option to change the primary copy, NetBackup first searches for the backup ID that belongs to the client. This search is useful if the client name has changed.
- `-cn copy_number|-primary`
Determines the copy number to duplicate. Valid values are 1 through 10. The default is 1.
`-primary` indicates to `bpduplicate` to search or duplicate the primary copy.
- `-dp destination_volume_pool_name [,copy2,...,copyn]`
Specifies the volume pool for the duplicates. NetBackup does not verify that the media ID that is selected for the duplicate copy is not the same media ID where the original resides. Therefore, to avoid the possibility of a deadlock, specify a different volume pool than where the original media ID resides. The default pool name is `NB_duplicates`.
Specify a pool for each copy that you specify.
- `-dstunit destination_storage_unit_label [,copy2,...,copyn]`
Specifies the destination storage unit. This parameter is required to duplicate backups. Do not specify this option to preview backups to be

duplicated (`-p`, `-pb`, `-PM`, or `-PD` options) or to change the primary copy (`-npc` option). This option does not have a default.

Specify a storage unit for each copy that you specify.

`-e date`

`-s date`

Specifies the end (`-e`) or start (`-s`) of the range of dates and times that include all backups to duplicate. The default end date is the current date and time. The default start time is 24 hours before the current date and time.

`-fail_on_error 0|1[,0|1,...,0|1]`

Specifies whether to fail the other duplications if the copy fails, where:

0 - Do not fail the other copies

1 - Fail the other copies

Specify one for each copy that you specify.

`-hoursago hours`

Specifies the number of hours before the current time to search for backups. Do not use with the `-s` option. The default is the previous midnight.

`-id media_id`

Search the image catalog for backups to duplicate that are on this media ID. If the original is fragmented between different media IDs, NetBackup duplicates only the backups that exist on the specified media ID. Backups that span media are duplicated, but not any other backups on the spanned media ID.

`-L output_file [-en]`

Specifies the name of a file in which to write progress information. The default is not to use a progress file.

Include the `-en` option to generate a log in English. The name of the log contains the string `_en`. This option is useful to support the personnel that assist in a distributed environment where different locales may create logs of various languages.

`-local`

When `bpduplicate` runs from a host other than the master server and `-local` is *not* used (default) the following occurs: it starts a remote copy of the command on the master server.

The remote copy allows the command to be terminated from the Activity Monitor.

Use this option to prevent the creation of a remote copy on the master server. You can also run `bpduplicate` only from the host where it was initiated.

If the `-local` option is used, `bpduplicate` cannot be canceled from the Activity Monitor.

`-M master_server`

Specifies the master server that manages the media catalog that has the media ID. If this option is not specified, the default is one of the following:

For NetBackup Server:

NetBackup Server supports only one server (the master) with no remote media servers. Therefore, the default in this case is always the NetBackup Server master where you run the command.

For NetBackup Enterprise Server:

If the command is run on a master server, then that server is the default.

If the command is run on a media server that is not the master, then the master for that media server is the default.

`-mpx`

Specifies that when you duplicate multiplexed backups, NetBackup creates multiplexed backups on the destination media, which reduces the time to duplicate multiplexed backups.

Multiplexed duplication is not supported for:

- Non-multiplexed backups
- Backups from disk type storage units
- Backups to disk type storage units
- FlashBackup or NDMP backups

If backups in the previous categories are encountered during duplication, NetBackup duplicates them first and uses non-multiplexed duplication. Then, the multiplexed backups are duplicated by using multiplexed duplication.

If all the backups in a multiplexed group are not duplicated, the duplicated multiplexed group have a different layout of fragments. (A multiplexed group is a set of backups that were multiplexed together during a single multiplexing session.)

If this option is not specified, all backups are duplicated by using non-multiplexed duplication.

For more information on multiplex operations, see the *NetBackup Administrator's Guide*.

`-npc new_primary_copy`

Allows the primary copy to be changed. The value can be 1 through 10. The `-backupid` option must be specified with this option.

`-number_copies number`

Specifies the number of copies to be created. Without the Inline Tape Copy option or NetBackup Vault extension that is installed, the value can be set to 1 only. The default is 1.

Use with `-dstunit`, `-dp`, `-fail_on_error`, and `-r1`:

`-number_copies 2 -dstunit stunit-copy1, stunit-copy2`

`-number_copies 2 -dp pool1, pool2`

`-owner media_share_group [,share_group_copy2,... share_group_copyn]`

Specifies the share group for the duplicate. Specify a share group for each copy that you specify.

`-p`

Previews backups to be duplicated according the option settings, but does not perform the duplication. Displays the media IDs, server name, backups that are not candidates for duplication (and why), and information about the backups to be duplicated.

`-pb`

Previews the duplication but does not perform the duplication. Similar to the `-p` option, but does not display information about the backups.

`-PD`

Same as the `-PM` option, except that it sorts and displays the backups by date and time (newest to oldest).

`-PM`

Displays the information on the backups to be duplicated according to the option settings, but does not perform the duplication. This format first displays the backup IDs that cannot be duplicated and why (for example, because the backup already has two copies). It displays the following information about the backup: date and time of the backup, policy, schedule, backup ID, host, media ID or path, copy number, and whether the copy is the primary copy:

1 = Primary copy

0 = Not primary copy

`-policy name`

Searches for backups to duplicate in the specified policy. The default is all policies.

`-priority number`

Enables you to configure backup policies to run at a lesser or a higher priority than disk staging duplication.

`-pt policy_type`

Search for the backups that the specified policy type created. The default is any policy type.

Valid values are:

Informix-On-BAR

Oracle

Macintosh

MS-Exchange-Server

MS-Windows

MS-SharePoint

MS-SQL-Server

NDMP

Netware

OS/2

Standard

Sybase

Note: The following policy types apply only to NetBackup Enterprise Server.

AFS

DataTools-SQL-BackTrack

DB2

FlashBackup

SAP

Split-Mirror

`-rl retention_level[,rl-copy2,...,rl-copyn]`

Provides a retention level for each copy that you specify.

If no retention levels are specified, the expiration date of the original copy is used for each copy. If a retention period is indicated, the expiration date for the copy is the backup date plus the retention period.

For example, if a backup was created on November 14, 2003, and its retention period is one week, the new copy's expiration date is November 21, 2003.

A value of -1 indicates that the original expiration date is used for the copy.

`-set_primary copy_index`

Specify a new copy to become the primary copy.

`copy_index` is one of the following:

0 = Do not change the primary copy (default)

1 = First new copy is the primary copy

2 = Second new copy is the primary copy

3 = Third new copy is the primary copy, and so on.

`copy_index` cannot be greater than the `bpduplicate -number_copies` value.

If the copy specified to be the primary copy fails, but other copies are successful, the primary copy does not change from its current value.

`-shost source_host`

Specifies that only the backups that are created on the specified backup server are considered for duplication. The default is to consider all backups regardless of the backup server.

`-sl sched_label`

Search for backups to duplicate that the specified schedule created. The default is all schedules.

`-st sched_type`

Search for backups to duplicate that the specified schedule type created. The default is any schedule type.

Valid values are:

FULL (full backup)

INCR (differential-incremental backup)

CINC (cumulative-incremental backup)

UBAK (user backup)

UARC (user archive)

NOT_ARCHIVE (all backups except user archive)

`-v`

Selects the verbose mode. When you specify the debug and progress logs, it includes more information.

NOTES

The format that you must use for date and time values in NetBackup commands varies according to your locale setting.

If you are uncertain of the NetBackup command requirements for your locale, enter the command with the `-help` option and check the USAGE. For example, the following is the output for the `-s` and `-e` options:

```
[-s mm/dd/yyyy HH:MM:SS] [-e mm/dd/yyyy HH:MM:SS]
```

Notice the month/day/year and hours:minutes:seconds requirements. These are for a locale setting of C and can be different for other locales.

EXAMPLES

Example 1

The following command (all on one line) lists backups with a copy number of 1. They were backed up by the policy that is named `stdpolicy`, and created between July 1, 2006, and August 1, 2006.

```
bpduplicate -PM -cn 1 -policy stdpolicy -s 07/01/06 -e  
08/01/06
```

Example 2

The following command can be all on one line, or you can use a backslash continuation character. The command duplicates copy 1 of the backups that are listed in file `bidfile` in the `tmp` directory. The destination storage unit is `unit1` and the destination pool is `dup_pool`. Progress information is written to `bpdup.ls`.

```
bpduplicate -dstunit unit1 -Bidfile C:\tmp\bidfile  
-L C:\tmp\bpdup.ls -dp dup_pool -cn 1
```

Example 3

The following command can be all on one line, or you can use a backslash continuation character. It is the same as the previous example, except multiplexed backups are duplicated by using multiplexed duplication.

```
bpduplicate -dstunit unit1 -Bidfile C:\tmp\bidfile -mpx  
-L C:\tmp\bpdup.ls -dp dup_pool -cn 1
```

FILES

```
install_path\NetBackup\db\images\*  
install_path\NetBackup\logs\admin\*
```

bpererror

NAME

bpererror - display NetBackup status and troubleshooting information or entries from NetBackup error catalog

SYNOPSIS

```
install_path\NetBackup\bin\admincmd\bpererror {-S | -statuscode  
  status_code} [-r|-recommendation] [[-p Unx | NTx]|[-platform Unx |  
  NTx]] [-v]  
  
install_path\NetBackup\bin\admincmd\bpererror [-all | -problems | -media |  
  tape] {-backstat [-by_statcode]}} [-L | -l | -U] [-columns ncols] [-d  
  date | -hoursago hours] [-e date] [-client client_name] [-server  
  server_name] [-jobid job_id] [-M master_server,...] [-v]  
  
install_path\NetBackup\bin\admincmd\bpererror [-s {severity[+]}|severity  
  ...] [-t type ...] [-dt disk type ...] [-L | -l|-U] [-columns ncols]  
  [-d date | -hoursago hours] [-e date] [-client client_name] [-server  
  server_name] [-jobid job_id] [-M master_server,...] [-v]
```

DESCRIPTION

bpererror displays information from either the same source as the online troubleshooter (in the Activity Monitor or Reports applications) or from the NetBackup error catalog. **bpererror** provides the following types of displays:

- A display of the message that corresponds to a status code and, optionally, a recommendation on how to troubleshoot the problem. In this case, the display results come from the same source as the online troubleshooter for the local system.
- A display of the error catalog entries that satisfy the command-line options. For instance, **bpererror** can display all the problem entries for the previous day.
- A display of the error catalog entries that correspond to a particular message severity and message type.

For information on details of the displays, see DISPLAY FORMATS later in this command description.

bpererror writes its debug log information to the following directory:

```
install_path\NetBackup\logs\admin
```

You can use the information in this directory for troubleshooting.

The output of `bpcerror` goes to standard output.

Authorized users can execute this command.

For more information about NetBackup authorization, refer to the *NetBackup Security and Encryption Guide*.

OPTIONS

`-all`

`-backstat [-by_statcode]`

`-media`

`-problems`

These options specify the type and severity of log messages to display. The default type is ALL. The default severity is ALL.

For `-all`: The type is ALL, and severity is ALL. Run `bpcerror` with this option and `-U` to produce an All Log Entries report.

For `-backstat`: The type is BACKSTAT, and severity is ALL. If `-by_statcode` is present, the display contains one entry for each unique status code. Line 1 of the entry contains the status code and the corresponding message text. Line 2 of the entry contains the list of clients for which this status code occurred. `-by_statcode` is only valid when the command line contains both `-backstat` and `-U`. Run `bpcerror` with this option and `-U` to produce a Backup Status report.

For `-media`: The type is MEDIADEV, and severity is ALL. Run `bpcerror` with this option and `-U` produces a Media Logs report.

For `-problems`: The type is ALL, and severity is the union of WARNING, ERROR, and CRITICAL. Run `bpcerror` with this option and `-U` to produce a Problems report.

`-client client_name`

Specifies the name of a NetBackup client. This name must be as it appears in the NetBackup catalog. By default, `bpcerror` searches for all clients.

`-columns ncols`

For the `-L` and `-U` reports, `-columns` provides an approximate upper bound on the maximum line length. `bpcerror` does not attempt to produce lines exactly `ncols` characters in length.

`-columns` does not apply to the `-l` report.

`ncols` must be at least 40. The default is 80.

`-d date`

`-e date`

Specifies the start date and end date range for the listing.

`-d` specifies a start date and time for the listing. The resulting list shows only images in the backups or archives that occurred at or after the specified date and time. The format of date depends on the user's locale setting. See the NOTES section for more information. For the C locale, the date syntax is as follows:

mm/dd/yy [hh[:mm[:ss]]]

The valid range of dates is from 01/01/1970 00:00:00 to 01/19/2038 03:14:07. The default is 24 hours before the current date and time.

The method you use to specify the date and time is dependent on the `locale` setting for your system. See NOTES.

`-e` specifies an end date and time for the listing. The resulting list shows only files from backups or the archives that occurred at or before the specified date and time. Use the same format as for the start date. The default is the current date and Time. The end date must be greater than or equal to the start date.

`-dt` *disk type*

Enables the user to specify a disk type. The following are the valid values for *disk type*:

0 - All

1 - BasicDisk

2 - NearStore

3 - SnapVault

6 - DiskPool

`-help`

Prints a command line usage message when `-help` is the only option on the command line.

`-hoursago` *hours*

Specifies a start time of many hours ago, which is equivalent to specifying a start time (`-d`) of the current time minus hours. Hours is an integer. The default is 24, which is a start time of 24 hours before the current time.

`-jobid` *job_id*

Specifies a NetBackup job ID. By default, `bperorr` searches for all job IDs.

`-L`

Report in long format.

`-l`

Report in short format. This report produces a terse listing. This option is useful for scripts or programs that rework the listing contents into a customized report format. This option is the default list type.

`-M master_server,...`

Specifies a comma-separated list of one or more hostnames. The command is run on each of the master servers in this list. The master servers must allow access by the system that issues the command. If an error occurs for any master server, the process stops at that point in the list. The default is the master server for the system where the command is entered.

`-p Unx | NTx`

`-platform Unx | NTx`

Display the message that applies to the platform (UNIX or Windows) for the specified status code. The default is to display the message for the platform on which `bperorr` is running. The `-S` or `-statuscode` option must be specified when you use this option.

`-r | -recommendation`

Displays the recommended action for the specified status code from the troubleshooting guide. The default is not to display the recommendation. The `-S` or `-statuscode` option must be specified when you use this option.

`-S status_code`

`-statuscode status_code`

Display the message that corresponds to the status code. This option has no default condition.

`-s severity`

`-s severity+`

Specifies the severity of log messages to display. The defined values are ALL, DEBUG, INFO, WARNING, ERROR, and CRITICAL.

You can specify severity in two ways. The first way is a list of one or more severity values. For instance, "`-s INFO ERROR`" displays the messages with either severity INFO or severity ERROR. The delimiter between the elements in the list must be a blank (" "). The second way is a single severity value with "+" appended, which is this severity or greater. For instance "`-s WARNING+`" displays the messages with severity values WARNING, ERROR, and CRITICAL.

The default is ALL. The severity value can be in either upper or lower case.

`-server server_name`

Specifies the name of a NetBackup server. This name must be as it appears in the NetBackup catalog. The display is limited to the messages that were logged for this server, which also satisfy the other criteria that `bperorr` options specified. For example, if `-server plim` and `-hoursago 2` are `bperorr` options, the display contains the messages that were logged for the media server `plim` in the past two hours.

The server name must match the server name that was recorded in the log messages. For instance, if the logs record the server name as `plim.null.null.com`, which specifies `-server plim` does not display the logs, but `-server plim.null.null.com` does.

The query goes to the error catalog which resides on either the local master server or the master server that `-M` specifies. The master server must allow access by the system running `berror`.

The default is to display log messages for all media servers that are known to the master server(s).

`-t type`

Specifies the type of log messages to display. The defined values are `ALL`, `BACKSTAT`, `MEDIADEV`, `GENERAL`, `BACKUP`, `ARCHIVE`, `RETRIEVE`, and `SECURITY`. The default is `ALL`. The type value can be in either upper or lower case. The type value is entered as a list of one or more values. For instance, "`-t BACKSTAT MEDIADEV`" displays the messages with either type `BACKSTAT` or type `MEDIADEV`. The delimiter between the elements in the list must be a blank (" ").

`-U`

Reports in user format. NetBackup report-generating tools such as the NetBackup-Java Reports application uses this report.

`-v`

Selects verbose mode. This option causes `berror` to log additional information for debugging purposes. The information goes into the NetBackup-administration daily debug log. This option is meaningful only when NetBackup has debug logs enabled (`install_path\NetBackup\logs\admin/usr/opensv/netbackup/logs/admin` directory defined). The default is to not be verbose.

DISPLAY FORMATS

- Status code display (for example, `berror -S status_code`):
`berror` queries the NetBackup online troubleshooter on the local system for the message that corresponds to the status code. `berror` displays the message text on one line and an explanation on a second line.
If `-r` or `-recommendation` is an option, `berror` also queries for the troubleshooting recommendation that corresponds to the status code. `berror` displays the recommendation following the status message, on one or more lines.
- Error catalog display (for example, `berror -all`; `berror -s severity`):

`bperrot` queries the NetBackup error catalog on either the local master server or the master servers in the `-M` option list. The display consists of the results that are returned from querying the error catalog on the master server(s). The results are limited to catalog the entries that satisfy all the `bperrot` options. For example, the `bperrot` command line may contain options for client, start time, and end time. If so, then `bperrot` reports only the jobs that are run for that client between the start time and end time. The display variant that shows individual message entries from the error catalog can appear in long (`-L`), user (`-U`), or short (`-l`) format. The display variant that categorizes by status code can appear in user (`-U`) format only. The following is the display content for each of these formats:

- Error catalog display, individual message entries, long format (for example, `bperrot -media -L`). This report produces several lines per log entry, with the following contents:

Line 1: Date and time

V:NetBackup version

S:Server

C:Client

J:Job ID

(U:Job group ID and an unused field.) If multi-streaming is enabled for a policy, the job group ID is the job ID of the first job that spawned a collection of multi-streaming backups. If multi-streaming is disabled for the policy, the job group ID is always zero.

Line 2: Severity (severity name and severity code in hexadecimal)

Type (type name and type code in hexadecimal)

Who (name of the entity that added the log entry)

Line 3: Text (at the start of the log message text, continued on subsequent lines if necessary)

- Error catalog display, individual message entries, user format (for example, `bperrot -media -U`). The user format produces a header line showing column names, and then one or more lines per log entry with the following contents:

Line 1: Date and time

Server

Client

Text (at the start of the log message text, continued on subsequent lines if necessary)

- Error catalog display, individual message entries, short format (for example, `bperrot -media -l`). The short format produces a single line per log entry, with the following contents:

Line 1: Time (internal system representation)

NetBackup version
 Type code (decimal)
 Severity code (decimal)
 Server
 Job ID
 Job Group ID
 An unused field
 Client
 Who
 Text (the entire log message text, with no truncation of the line length)

- Error catalog display categorized by status code. This display reports only each unique status code, instead of listing every log entry for that status code (for example, `berror -backstat -by_statcode -U`). This option produces two or more lines per status code, with the following contents:
 - Line 1: Status code
 - Text (the beginning of the log message text, continued on subsequent lines if necessary)
 - Line 2: The list of clients for which this status occurred.

NOTES

The format that you must use for date and time values in NetBackup commands varies according to your locale setting.

If you are uncertain of the NetBackup command requirements for your locale, enter the command with the `-help` option and check the USAGE. For example, the following is the part of the `berror` usage output:

```
USAGE: berror ...
        [-d mm/dd/yyyy hh:mm:ss|-hoursago hours]
        [-e mm/dd/yyyy hh:mm:ss] [-client client_name] ...
```

Notice the month/day/year and hours:minutes:seconds requirements for the `-d` and `-e` options. These are for a locale setting of C and can be different for other locales.

For more information on locale, see the `locale(1)` man page for your system.

EXAMPLES

Example 1

Here `berror` displays the error for a job that failed because the NetBackup encryption package was not installed. Status code 9 is the NetBackup status code for this failure. The second run of `berror` displays the action that is recommended for NetBackup status code 9.

```
berror -d 12/23/2003 16:00:00 -e 12/23/2003 17:00:00 -t backstat -U
```

```

STATUS CLIENT    POLICY    SCHED    SERVER    TIME COMPLETED
9         plim     dhcrypt  user     plim     12/23/2003 16:38:09
        (an extension package is needed, but was not
        installed)

```

```

bpperor -S 9 -r
        an extension package is needed but was not installed
        A NetBackup extension product is required in order to
        perform the requested operation.
        Install the required extension product.

```

Example 2

bpperor reports the problems in User format that have occurred in the previous 24 hours.

```

bpperor -U -problems
TIME                SERVER CLIENT - TEXT
11/23/2003 16:07:39 raisins - no storage units
configured
11/23/2003 16:07:39 raisins - scheduler exiting -
failed reading storage unit database information (217)
11/23/2003 16:17:38 raisins - no storage units
configured
11/23/2003 16:17:38 raisins - scheduler exiting -
failed reading storage unit database information (217)
11/23/2003 16:26:17 raisins - WARNING: NetBackup
database backup is currently disabled
11/23/2003 18:11:03 raisins nut bpcd on nut exited
with status 59: access to the client was not allowed
11/23/2003 18:11:20 raisins - WARNING: NetBackup
database backup is currently disabled

```

Example 3

The following example displays status for type backstat for the jobs that are run in the previous 24 hours. The option `-by_statcode` produces a display that is organized by status code.

The display shows that one or more jobs for each of the clients chive, gava, and raisins have completed successfully (the status code is 0). In addition, one or more jobs for client nut have failed because nut did not allow access by the master server or media server. (The status code is 59.)

```

bpperor -U -backstat -by_statcode
0    the requested operation was successfully completed
    chive gava raisins
59   access to the client was not allowed
    nut

```

Example 4

The following example identifies and retrieves the results for a particular user job. It first lists the log entries with job Ids other than zero. It then runs a User-format report on the job of interest.

```

bpcerror -hoursago 2002 -L | grep 'S:' | egrep 'J\:[1-9]'
12/21/2003 17:24:14 V1 S:plim C:plim J:1 (U:0,0)
12/23/2003 16:31:04 V1 S:plim C:plim J:1 (U:0,0)
12/23/2003 16:31:06 V1 S:plim C:plim J:1 (U:0,0)
12/23/2003 16:38:04 V1 S:plim C:plim J:3 (U:0,0)
12/23/2003 16:38:07 V1 S:plim C:plim J:3 (U:0,0)
12/23/2003 16:38:08 V1 S:plim C:plim J:3 (U:0,0)
12/23/2003 16:38:09 V1 S:plim C:plim J:3 (U:0,0)
01/07/2002 13:12:31 V1 S:plim C:plim J:34 (U:0,0)
01/07/2002 13:12:36 V1 S:plim C:plim J:34 (U:0,0)
01/07/2002 13:12:40 V1 S:plim C:plim J:34 (U:0,0)
01/07/2002 13:12:41 V1 S:plim C:plim J:34 (U:0,0)
bpcerror -d 1/7/2002 -jobid 34 -U
  TIME                SERVER CLIENT - TEXT
01/07/2002 13:12:31 plim plim started backup job for
client plim, policy jdencrypt, schedule user on storage
unit jdencrypt
01/07/2002 13:12:36 plim plim begin writing backup id
plim_0947272350, copy 1,fragment 1
01/07/2002 13:12:40 plim plim successfully wrote backup
id plim_0947272350,copy 1, fragment 1, 32 Kbytes at
11.057 Kbytes/sec
01/07/2002 13:12:41 plim plim CLIENT plim POLICY jdencrypt
SCHED user EXIT STATUS 0 (the requested operation was
successfully completed)

```

Example 5

The following example shows the media entries in the error catalog for the past 2000 hours.

```

bpcerror -hoursago 2000 -media -U
  TTIME                SERVER CLIENT - TEXT
12/23/2003 16:31:04 plim plim Media Manager terminated
during mount of media id A00000, possible media mount
timeout
12/24/2003 04:31:20 plim - media id A00000 removed from
Media Manager database (manual deassign)

```

Example 6

The following example tallies and reports the total number of bytes backed up in the past 24 hours.

```
berror -all -hoursago 24 | grep "successfully wrote  
backup id" | awk '{bytes= bytes + $20} END {print "backed  
up",bytes," Kbytes of data"}'  
    backed up 64 Kbytes of data  
up",bytes," Kbytes of data}'
```

bpexpdate

NAME

bpexpdate - change expiration date of backups in image catalog and media in media catalog

SYNOPSIS

```
install_path\NetBackup\bin\admincmd\bpexpdate -m media_id -d date | 0 | infinity [-host name] [-force] [-nodelete] [-notimmediate] [-M master_server,...]

install_path\NetBackup\bin\admincmd\bpexpdate -deassignempty [-m media_id] [-force] [-M master_server,...]

install_path\NetBackup\bin\admincmd\bpexpdate -backupid backup_id -d date | 0 | infinity [-client name] [-copy number] [-force] [-nodelete] [-notimmediate] [-M master_server,...]

install_path\NetBackup\bin\admincmd\bpexpdate -recalculate [-backupid backup_id] [-copy number] [-d date | 0 | infinity] [-client name] [-policy name] [-ret retention_level] [-sched type] [-M master_server,...]

install_path\NetBackup\bin\admincmd\bpexpdate -stype server_type [-dp disk_pool_name] [-dv disk_volume] [-nodelete] [-notimmediate] [-M master_server,...]
```

DESCRIPTION

NetBackup maintains internal databases with backup image and media information. These internal databases are called catalogs. The image record in the image catalog contains an expiration date. The media ID in the media catalog also contains an expiration date. The expiration date is the date and time when NetBackup removes the record for a backup or a media ID from the corresponding catalog.

The `bpexpdate` command allows the expiration date and time of backups to be changed in the NetBackup image catalog. The command is also used to change the expiration of removable media in the NetBackup media catalog. If the date is set to zero, `bpexpdate` immediately expires backups from the image catalog or media from the media catalog. When a media ID is removed from the NetBackup media catalog, it is also removed from the Enterprise Media Manager Database. It is removed regardless of the media's previous state (FROZEN, SUSPENDED, and so on).

You can change the expiration on a media ID basis or on an individual backup ID basis. When you change the expiration date of a media ID, the expiration date of all backups on the media are also changed. `bpexpdate` also provides the following options:

- Remove media from the media catalog if they no longer contain valid backups
- Recalculate the expiration date to base it on the configured or a supplied retention level

Any authorized user can run this command.

For more information about NetBackup authorization, refer to the *NetBackup Security and Encryption Guide*.

The different formats of the command are as follows:

`-backupid`

Changes the expiration of a single backup. If the date is zero, the backup is removed from the image catalog. If the backup is on removable media and the `-d` expiration is greater than the current media ID expiration, the media catalog expiration also changes. The change affects all copies of a backup, unless the `-copy` option is used. The `-copy` option causes only the specified copy to be affected.

`-deassignempty`

Searches the catalog for the removable media that no longer contain valid backups. It removes the media from the media catalog and removes the media IDs in the Media Manager catalog. The media is then available to use again. You can use the NetBackup Images on Media report to determine if the assigned media no longer contains valid backups.

`-m`

Changes the expiration date or removes the media ID from the media catalog and associated backups from the NetBackup catalog. A separate expiration date is maintained in the image catalog for each copy of a backup. When this format is used, only the expiration of the copy on the media is affected. If you remove the media ID from the media catalog by specifying a zero date, you also remove it in the Enterprise Media Manager Database.

`-recalculate`

Allows the expiration date of backups to be changed based on the specified retention level, or you can specify a new expiration date. When the expiration changes according to retention level, the new date is based on the creation date of the backup plus the retention level value. The expiration can be changed for a single backup, or for all backups for a particular client, policy, or schedule type.

If the backup is on removable media, the expiration in the media catalog changes if the command expiration is greater than the current expiration.

`-stype server_type`

A string that identifies the storage server type. Possible values are AdvancedDisk, OpenStorage (*vendorname*), PureDisk, and SharedDisk.

OPTIONS

`-client name`

Specifies the client name for the `-backupid` and `-recalculate` operations.

For the `backupid` operation, this option causes NetBackup to first search for the backup ID for the specified client. This option is useful if the client name has changed.

For `recalculate`, this option causes NetBackup to recalculate the expiration date to be based on the retention level for all the specified client backups.

`-copy number`

Expires or changes the expiration date of the specified copy number and is valid only with the `-backupid` and `-recalculate` options. Valid values are 1 through 10.

If the primary copy is expired, the other copy becomes the primary copy. If this option is not specified, the expiration affects both copies of the backup.

`-d date`

Specifies the expiration date and time. *date* can be any one of the following:

mm/dd/yy hh:mm:ss

or

0

or

infinity

If 0 is specified, the backup or media expires immediately. If *infinity* is specified, the backup never expires.

`-deassignempty`

Expires the removable media from the media catalog when that media no longer contains valid backups. It also deassigns the media ID in the Media Manager catalog.

`-dp disk_pool_name -dv disk_volume`

Specifies the disk pool and, optionally, the disk volume for the expiration date operation to be performed.

`-force`

Before you run the specified operation, `bpexpdate` queries before it starts the operation. This option forces the `bpexpdate` command to carry out the operation without querying the user.

`-host name`

Note: For NetBackup Server, this option is not required because only one server (the master) exists. If you do use the option, specify the host name of that server.

Specifies the host name of the server to which the media is assigned. This option should be used only with the `-m media_id` option, and then only if the master has remote media servers and the volume was not written on the server where you run `bpexpdate`.

For example, assume you have a master server named `whale` and a media server named `eel`. You run the following command on `whale` to remove media ID `BU0001` manually from the media catalog and all corresponding backups from the image catalog:

```
bpexpdate -m BU0001 -d 0 -host eel
```

You can use the NetBackup Media List report to determine which server's media catalog has the volume.

`-m media_id`

Specifies the media ID that the expiration date change affects. The expiration dates of the backups on the media ID also change. The `-d` option must be included with this option.

This option can also be used when the `-deassignempty` option is specified to check if valid backups exist on this particular media ID. In this case, do not include the `-d` option.

The media ID must be six or less characters and must be in the NetBackup media catalog.

`-M master_server [, ...]`

Specifies the master server that manages the media catalog that has the media ID. If this option is not specified, the default is one of the following:

For NetBackup Server:

NetBackup Server supports only one server (the master) with no remote media servers. Therefore, the default in this case is always the master server where you run the command.

For NetBackup Enterprise Server:

If the command is run on a master server, then that server is the default.

If the command is run on a media server that is not the master, then the master for that media server is the default.

`-nodelete`

Deletes the backup from the image catalog but does not delete it from the disk storage. Use this option when you unimport a disk group from one master server and import the disk group to a different master server.

`-notimmediate`

Inhibits the call that `bpexpdate` makes to the `nbdelete` command after it expires an image on disk. If you intend to delete many images at the same time, use `-notimmediate` to avoid the overhead of multiple job creation for `nbdelete` to process. You can then run the `nbdelete` command later.

`-policy name`

Specifies the policy name and is valid with the `-recalculate` option. When the policy name is specified, the expiration is recalculated based on the retention level for all backups that are created in this policy.

`-recalculate`

Recalculates the expiration of backups that are based on the retention level or you can specify a new expiration date. You can include other options to change the expiration for a single backup, or for the following: all backups for a specific client name, policy name, or schedule type. Either the `-d` or `-ret` option must be specified with this option.

`-ret retention_level`

Specifies the retention level to use when you recalculate expiration dates and is valid with the `-recalculate` option. Levels range from 0 to 24. To determine the new expiration date, add the configured retention level value to the backup's creation date. Either the `-backupid` or `-policy` option must be specified with this option.

`-sched type`

Specifies the schedule type and is valid with the `-recalculate` option. When the type is specified, the expiration is recalculated based on the retention level for all backups that are created with this schedule type. Enter a numeric value for type as follows:

0 = Full

1 = Differential Incremental

2 = User Backup

3 = User Archive

4 = Cumulative Incremental

The `-policy` option must be specified with `-sched`.

NOTES

The format that you must use for date and time values in NetBackup commands varies according to your locale setting.

If you are uncertain of the NetBackup command requirements for your locale, enter the command with the `-help` option and check the USAGE. For example, the following is the output for the `-d` option:

```
-d <mm/dd/yyyy HH:MM:SS | 0 | infinity>
```

Notice the month/day/year and hours:minutes:seconds requirements. These are for a locale setting of C and can be different for other locales.

See the `locale(1)` man page for detailed information.

Some options in large environments can take a significant amount of time to complete. Changes that cause backups or media to expire are irrevocable. You can be required to import backups and (or) recover previous versions of the catalogs if you make mistakes by using this command.

EXAMPLES

Example 1

The following command, run on the master server, removes media ID BU0002 from the media catalog. It deassigns the media ID in the Media Manager catalog. It also expires associated image records in the image catalog.

```
bpexpdate -m BU0002 -d 0
```

Example 2

The following command changes the expiration of copy 2 of backupid eel_0904219764. It does not affect the expiration of copy 1 of the backup.

```
bpexpdate -backupid eel_0904219764 -d 12/20/2003 08:00:00  
-copy 2
```

Example 3

The following command removes the backup from the image catalog. Since the `-copy` option is not specified, all copies are removed.

```
bpexpdate -backupid eel_0904219764 -d 0
```

Example 4

The following command checks for all media in the host cat's media catalog that are still assigned, but which no longer contain valid backups. If any such media are found, the command removes them from the media catalog and deassigns them in the Media Manager catalog.

```
bpexpdate -deassignempty -host cat
```

FILES

```
install_path\NetBackup\logs\admin\*
```

```
install_path\NetBackup\db\media\*
```

```
install_path\NetBackup\db\images\*
```

bpfis

NAME

bpfis - create or delete a snapshot, or return information about existing snapshots

SYNOPSIS

```
install_path\bin\bpfis create [-rhost host] [-id id] [-v] [-V] [-owner  
owner] [-help] -fim fim_name[:option=value,option=value, ...] file1  
[file2 ...]  
  
install_path\bin\bpfis delete [-force] -id id  
  
install_path\bin\bpfis fim method  
  
install_path\bin\bpfis query [-id id]
```

DESCRIPTION

The `bpfis` command can create, delete, or query snapshots of a client system (filesystem or volume).

Note: To store the image on tape or other media requires that you run a separate backup job.

For more detailed examples and procedures for using `bpfis`, refer to the *NetBackup Snapshot Client Administrator's Guide*.

You must have administrator privileges to run this command.

OPTIONS

`-rhost`

The remote host or alternate client on which the snapshot is made accessible. The default is the local host.

The `-rhost` option can be used with the FlashSnap method only.

`-id`

For `bpfis create`, this option is a user-defined snapshot identifier. The default ID is a time stamp that shows when the image was created.

For `bpfis delete`, this option designates the ID of the snapshot to be deleted.

For `bpfis query`, this option designates the ID of the snapshot for which to return information.

- `-v -V`
Indicates the verbosity levels in the log files. `-V` is a higher level of verbosity than `-v`. Default is nonverbose.
- `-owner`
Specifies the owner of this snapshot (default is GENERIC).
- `-help`
Displays the `bpfis` usage statement.
- `-fim fim_name[:option=value,option=value, ...]`
Specifies the snapshot method to use to create the image. Select the method by using the type of data and hardware that the client uses.
For details on snapshot methods, refer to the *NetBackup Snapshot Client Administrator's Guide*.
The available options depend on the snapshot method. For a list of snapshot methods and their options, refer to the `<opt_params>` area of each snapshot method (FIM) listed in the `vfim.conf` file.
For example, under the BusinessCopy snapshot method, the first optional parameter is listed as follows:
`keep_fi=%b[0]#Keep frozen image after backup`
where `keep_fi=` is the option, and the value is boolean (0 for no, 1 for yes).
For an example of the `bpfis` command using `option=value`, refer to `bpfis` in the *NetBackup Snapshot Client Administrator's Guide*.
- `file1 file2`
Specifies the path of the file system or volume from which the snapshot is to be made.
- `-force`
Specifies the force delete.

EXAMPLES

Example 1

To create a snapshot of `E:\` on `hostB` by using the FlashSnap method on a Windows client:

```
install path\bin\bpfis create -rhost hostB -fim FlashSnap
E:\
```

Sample output:

```
INF - BACKUP START 26808
INF - FIS_ID=1034037338
INF - REMAP FILE BACKUP E: USING <GUID>
OPTIONS:ALT_PATH_PREFIX=/tmp/_vrts_frzn_img_26808,FITYPE
```

```
INF - EXIT STATUS 0: the requested operation was successfully
completed
```

Example 2

To obtain information about a particular snapshot on the local host:

```
install_path\bin\bpfis query -id 1034037338
```

Sample output:

```
INF - BACKUP START 26838
INF - Frozen image host : ricochet
INF - Frozen image owner: GENERIC
INF - Time created      : Mon Oct  7 19:35:38 2002
INF - REMAP FILE BACKUP E: USING <GUID>
OPTIONS:ALT_PATH_PREFIX=/tmp/_vrts_frzn_img_26808,FITYPE=MIRROR,
MNTPOINT=E:\,FSTYPE=NTFS
INF - EXIT STATUS 0: the requested operation was successfully
completed
```

Example 3

To delete a snapshot on the local host:

```
install_path\bin\bpfis delete -id 1034037338
```

Sample output:

```
INF - BACKUP START 26839
INF - EXIT STATUS 0: the requested operation was successfully
completed
```

bpgetconfig

NAME

`bpgetconfig` - helper program to obtain configuration information

SYNOPSIS

```
install_path\bin\admincmd\bpgetconfig -M master [-x|X] [config_item ...]  
install_path\bin\admincmd\bpgetconfig [-u|h] [-x|X] [config_item ...]  
install_path\bin\admincmd\bpgetconfig -g server [-L|U|l]  
install_path\bin\admincmd\bpgetconfig -s server [-L|U|l]  
install_path\bin\admincmd\bpgetconfig -H [config_item]
```

DESCRIPTION

`bpgetconfig` can be used as a stand-alone program or as a helper program for the `backuptrace` and the `restoretrace` commands to obtain configuration information. This command is available for all NetBackup server platforms. It displays the configuration information of a specified server in various formats. You must have administrator privileges to run this command.

OPTIONS

- M *master*
Specifies the master server (*master*) whose host configuration appears.
- h
Displays the default, local host configuration.
- u
Displays the current user configuration.
- x
Excludes the items not explicitly listed in the configuration.
- X
Lists all configuration items by default. The `-x` and `-X` options may be combined with the `-M`, `-h`, and `-u` options. The `-x` and `-X` options have no effect if one or more configuration items are specified on the command line.

"*config_item*" ...
If specified, *config_item* appears on the specified configuration items.

`-g server`

Selects the host server (*server*) for which general Backup Exec and NetBackup information appears. Currently, the information is as follows:

- Master or Client
- NetBackup Client Platform
- NetBackup Client Protocol Level
- Product Type (for Backup Exec if installed, else NetBackup)
- Version Name (for Backup Exec if installed, else NetBackup)
- Version Number (for Backup Exec if installed, else NetBackup)
- Installed Path for NetBackup Bin (null if Backup Exec is installed)
- Installed OS for host server

`-s server`

Selects the host server (*server*) for which the general system information that is NetBackup specific appears. Currently, the information is as follows:

- Master or Client
- NetBackup Client Platform
- NetBackup Client Protocol Level
- Product Type (NetBackup)
- Version Name
- Version Number
- Installed Path for NetBackup Bin
- Installed OS for host server

`-L`

Displays a long, user-readable list.

`-U`

Displays a brief, user-readable list (default).

`-l`

Displays a compact, machine-readable list. The `-L`, `-U`, and `-l` options can be used with the `-g` or `-s` option.

`-H`

Displays the help screen.

`-H config_item`

Displays the valid configuration items.

bpgetdebuglog

NAME

bpgetdebuglog - Run helper program for backuptrace and restoretrace. Useful as a stand-alone program. Available for all NetBackup server platforms.

SYNOPSIS

```
install_path\NetBackup\bin\admincmd\bpgetdebuglogremote_machine  
[remote_program mmddyy]
```

DESCRIPTION

If all three arguments are specified, bpgetdebuglog prints to standard output the contents of the specified debug log file. If only *remote_machine* is specified, bpgetdebuglog prints to standard output the number of seconds of clock drift between the local machine and the remote machine. A positive number means that the local machine is ahead of the remote machine. A negative number means that the remote machine is ahead of the local machine.

The bpgetdebuglog command must be in the *install_path\NetBackup\bin\admincmd* directory in order for backuptrace and restoretrace to use it.

You must have administrator privileges to run this command.

OPTIONS

Remote_machine

Name of the remote server

remote_program

Name of the debug log directory on the remote server

mmddyy

The day stamp that is used to identify the log file (log.mmddyy for UNIX, mmddyy.log for Windows) to be read.

EXAMPLES

```
C:\Program  
Files\VERITAS\NetBackup\bin\admincmd\bpgetdebuglog peony
```

bpimage

NAME

`bpimage` - perform functions on stored images in a database

SYNOPSIS

```

install_path\NetBackup\bin\bpimage -[de]compress [-allclients | -client
name]
install_path\NetBackup\bin\bpimage [-M master_server,...,master_server]
install_path\NetBackup\bin\bpimage -npc copy # -backupid backupid [-client
name]
install_path\NetBackup\bin\bpimage -newserver newserver_name [-oldserver
oldserver_name] [-id id]
install_path\NetBackup\bin\bpimage -deletecopy # -backupid backupid
install_path\NetBackup\bin\bpimage -testlock # -backupid backupid
install_path\NetBackup\bin\bpimage -prunetir [-allclients | -client name]
-cleanup
install_path\NetBackup\bin\bpimage -create_image_list -client name
install_path\NetBackup\bin\bpimage -index index_number -client name
install_path\NetBackup\bin\bpimage -wff path_bytes -backupid backupid
[-client name]
install_path\NetBackup\bin\bpimage -update [-secinfo 0|1 | -rfile 0|1 |
-filesyonly 0|1 | -numfiles number | -keyword keyword_phrase |
-objdesc string] [-client name -policy name -t type -d mm/dd/yyyy
HH:MM:SS] [-id backup_id]

```

DESCRIPTION

This command can be used to perform many different functions to images that are stored in a database. Some of the functions are as follows:

- Compress and de-compress stored images
- Remove existing images from the database
- Test the locking capability on an image
- Create an image list file that can be used to qualify an image
- Index a client.

OPTIONS

The following options represent the criteria that determine which images or media are selected for the report. Where images are discussed in these options, media can be substituted if the context refers to a media report.

`-allclients`

Specifies the selection of all NetBackup clients that are already backed up on the system.

`-backupid backup_id`

Specifies a backup ID to use for finding applicable images.

`-client name`

Specifies a client name to use for finding backups or archives to list. This name must be as it appears in the NetBackup catalog.

`-cleanup`

Deletes expired images, compresses the images that are scheduled to be compressed, and prunes the TIR information from the specified images.

Note: This command enables a user to accomplish the same tasks manually that the scheduler performs on a regular basis. It can be used when the user does not have enough time to wait for the scheduler to perform these tasks.

`-create_image_list`

Creates an `image_list` file and an `image_info` file that can be used quickly to qualify an image.

`-d date`

Specifies the start date and end date range for the listing.

`-d` specifies a start date and time for the listing. The resulting list shows only images in backups or the archives that occurred at or after the specified date and time. The format of *date* depends on the user's locale setting.

For the C locale, the date syntax is as follows:

`mm/dd/yy [hh[:mm[:ss]]]`

The valid range of dates is from 01/01/1970 00:00:00 to 01/19/2038 03:14:07. The default is the previous midnight.

`-[de]compress`

Initiates an action to compress or de-compress a specified client, or all clients.

`-deletecopy #`

Removes the images that the copy number (#) and the `backup_id` specify.

`-filesysonly 0/1`

Depending on the setting, this option limits `bpimage` to query only the local file system.

`-id backup_id`

Specifies the backup ID when used with the `-update` command.

`-index n`

Indexes the database. The *n* variable is the index level and has a range from 1 to 9. A value of 9 provides the most optimum index. This option applies only to ASCII.

`-keyword "keyword_phrase"`

Specifies a keyword phrase for NetBackup to use when it searches. The phrase must match the one that was previously associated with the image.

`-objdesc string`

Specifies the object description string of the Informix client type when used with the `-update` command.

`-newserver name | -oldserver name`

Specifies the name (new or old) of a NetBackup server.

`-npc copy #`

Sets the specified image as the primary image, which is based on the copy number of the image.

`-numfiles number`

Specifies the number of files when used with the `-update` command.

`-M master_server,...`

Specifies a list of alternative master servers. This list is a comma-delimited list of hostnames. If this option is present, each master server in the list runs the `bpimage` command. If an error occurs for any master server, the process stops at that point.

The report is the composite of the information that all the master servers in this list returned. `bpimage` queries each of these master servers. The master server returns image or media information from the image catalogs. Each master server must allow access by the system that issues the `bpimage` command.

The default is the master server for the system running `bpimage`.

`-policy name`

Searches for backups to import in the specified policy. The default is all policies.

`-prunetir`

Prunes the True Image Restore (TIR) information from the specified clients. The default is all clients.

`-rfile 0/1`

Specifies the use of the Restore file when used with the `-update` command.

`-secinfo 0/1`

Specifies the use of Extended Security information on the NetWare client type.

`-t type`

Specifies a policy type. By default, `bpimage` searches for all policy types. `type` is one of the following character strings:

- Informix-On-BAR
- MS-Exchange-Server
- MS-SQL-Server
- MS-Windows
- NetWare
- Oracle
- OS/2
- Standard
- Sybase
- NDMP

Note that the following policy types apply only to NetBackup Enterprise Server.

- AFS
- DataTools-SQL-BackTrack
- DB2
- FlashBackup
- SAP
- Split-Mirror

`-update`

Updates an image that is based on the chosen parameter.

`-wff path bytes`

Writes the files `file` (image . `f` file) for the backup specified with `-backupID`.

bpimagelist

NAME

bpimagelist - produce status report on NetBackup images or removable media

SYNOPSIS

```

install_path\NetBackup\bin\admincmd\bpimagelist -l | -L | -U | -idonly
[-class_id class_id_guid] [-d date | -hoursago hours] [-e date]
[-keyword "keyword phrase"] [-client client_name] [-backupid
backup_id] [-option INCLUDE_PRE_IMPORT | INCLUDE_TIR |
LIST_COMPLETE_COPIES | LIST_OLD_TO_NEW | ONLY_PRE_IMPORT | ONLY_TIR]
[-policy policy_name] [-pt policy_type] [-rl retention_level] [-sl
sched_label] [-stl_complete] [-stl_incomplete] [-stl_name
storage_lifecycle_name] [-st sched_type] [-M master_server[,...]] [-v]

install_path\NetBackup\bin\admincmd\bpimagelist [-media] [-l | -L | -U |
-idonly] [-d date | -hoursago hours] [-e date] [-server server_name]
[-keyword "keyword phrase"] [-client client_name] [-option
INCLUDE_PRE_IMPORT | INCLUDE_TIR | LIST_COMPLETE_COPIES |
LIST_OLD_TO_NEW | ONLY_PRE_IMPORT | ONLY_TIR] [-policy policy_name]
[-pt policy_type] [-rl retention_level] [-sl sched_label] [-st
sched_type] [-M master_server[,...]] [-v]

```

DESCRIPTION

bpimagelist uses a specified format to report on catalog images or the removable media that match the attributes that are sent from the command options. It writes its debug log information to the following directory:

```
install_path\NetBackup\logs\admin
```

You can use the information in this directory for troubleshooting.

The output of bpimagelist goes to standard output.

Authorized users can run this command.

For more information about NetBackup authorization, refer to the *NetBackup Administrator's Guide*.

OPTIONS

Report-type options

`-media`

Specifies that the listing reports on the removable media that are based on a set of criteria. If `-media` is not in the command line, the report is on images, not media.

Report-format options

`-U`

Generates the report in User mode. The report is formatted. It includes a banner that lists the column titles. The status is a descriptive term instead of a number.

`-L`

Generates the report in Long mode. For instance, for the Media List report, the report lists the information for each media ID as a series of *attribute = value* pairs. The density value is provided as both a descriptive term and a number.

`-l`

Report in Short mode, which produces a terse listing. This option is useful for the scripts or programs that rework the listing contents into a customized report format.

`-idonly`

Produce an abbreviated list. For an image list, the list contains the creation time, backup ID, and schedule type of each image. For instance, if the list criterion is a window of time, the image list contains the following: for each image that is created in this window, only the creation time, backup ID, and schedule type of the image.

For a media list, the list contains only the applicable media IDs. For instance, if the list criterion is a window of time, the list contains only the media IDs that are written in this window.

The following options represent the criteria that determine which images or media are selected for the report. Where images are discussed in these options, media can be substituted if the report is a media report.

`-hoursago hours`

Includes the images that were written up to this many hours ago. This option is equivalent to a specification of a start time (`-d`) of the current time minus *hours*. *hours* must be 1 or greater.

`-option option_name,...`

Specifies a criterion or the multiple criteria for finding images to list. *option_name* is one of the following character strings, in uppercase or lowercase:

- `INCLUDE_PRE_IMPORT` - The report images that completed phase one of an import.
Refer to the `bpimport` command description or the *NetBackup Administrator's Guide* for more information.
- `INCLUDE_TIR` - The report images that true-image-recovery backups created.
Refer to the `bpccpinfo` command description or the *NetBackup Administrator's Guide* for more information on this topic.
- `LIST_COMPLETE_COPIES` - Do not report fragments of a duplicate copy that is still in process.
- `LIST_OLD_TO_NEW` - Report images by oldest to newest date.
- `ONLY_PRE_IMPORT` - Report only the images that completed phase one of an import.
- `ONLY_TIR` - Report only the images that true-image-recovery backups created.

The default is no restrictions on the selected images.

`-backupid backup_id`

Specifies a backup ID to use for finding applicable images (applies only to the image list).

`-class_id class_id_guid`

Specifies a class identifier to use to select images. The identifier represents a GUID (Globally Unique Identifier). The `bpimagelist` command reports only those images with the specified class identifier.

`-client client_name`

Specifies a client name to use for finding backups or archives to list. This name must be as it appears in the NetBackup catalog. By default, `bpimagelist` searches for all clients.

`-server server_name`

Specifies the name of a NetBackup server or `ALL`. This option applies to the media report (`-media`). If `-server` specifies a server name, the media in the report are only the media that reside on that server. The media also satisfy the other criteria that `bpimagelist` specifies. For instance, if `-hoursago 2` is specified, the media must contain an image that was created in the past two hours.

The query goes to the image catalog that resides on the local master server. The master server must allow access by the system running `bpimagelist`.

The default is to report all media in the image catalog on the local master server, which is equivalent to the specification of `-server ALL`.

`-stl_complete`

Reports only the images that the storage lifecycle completely processed. This option cannot be used with the `stl_incomplete` option.

`-stl_incomplete`

Reports only the images that the storage lifecycle has not completely processed. This option cannot be used with the `stl_complete` option.

`-stl_name storage_lifestyle_name`

Specifies a storage lifecycle name to be used when you select images. Only images with the specified storage lifecycle name are selected.

`-M master_server,...`

Specifies a list of one or more alternative master servers. This list is a comma-delimited list of hostnames. If this option is present, each master server in the list runs the `bpimagelist` command. If an error occurs for any master server, the process stops at that point.

The report is the composite of the information that all the master servers in this list return. `bpimagelist` queries each of these master servers. The master server returns image or media information from the image catalogs. Each master server must allow access by the system that issues the `bpimagelist` command.

The default is the master server for the system running `bpimagelist`.

`-pt policy_type`

Specifies a policy type. By default, `bpimagelist` searches for all policy types. `policy_type` is one of the following character strings:

- Informix-On-BAR
- MS-Exchange-Server
- MS-SQL-Server
- MS-SharePoint
- MS-Windows
- NetWare
- Oracle
- OS/2
- Standard
- Sybase
- NDMP

Note that the following policy types apply only to NetBackup Enterprise Server:

- AFS
- DataTools-SQL-BackTrack
- DB2
- FlashBackup
- SAP
- Split-Mirror

`-rl retention_level`

Specifies the *retention_level*. The *retention_level* is an integer between 0 and 24. By default, `bpimagelist` searches for all retention levels.

`-d date`

`-e date`

Specifies the start date and end date range for the listing.

`-d` specifies a start date and time for the listing. The resulting list shows only images in backups or the archives that occurred at or after the specified date and time. The format of *date* depends on the user's locale setting.

For the C locale, the date syntax is as follows:

`mm/dd/yy [hh[:mm[:ss]]]`

The valid range of dates is from 01/01/1970 00:00:00 to 01/19/2038 03:14:07. The default is the previous midnight.

`-e` specifies an end date and time for the listing.

The resulting list shows only files from backups or the archives that occurred at or before the specified date and time. Use the same format as for the start date. The default is the current date and time.

`-keyword "keyword_phrase"`

Specifies a keyword phrase for NetBackup to use when it searches. The phrase must match the one that was previously associated with the image. For instance, the `-k` option of the `bpbackup` or `bparchive` command associates a keyword with the image when the image is created.

`-sl sched_label`

Specifies a schedule label for the image selection. The default is all schedules.

`-st sched_type`

Specifies a schedule type for the image selection. The default is any schedule type. Valid values are as follows:

- FULL (full backup)
- INCR (differential-incremental backup)
- CINC (cumulative-incremental backup)
- UBAK (user backup)
- UARC (user archive)
- NOT_ARCHIVE (all backups except user archive)

`-policy name`

Searches for backups to import in the specified policy. The default is all policies.

Other options:

`-help`

Prints a command line usage message when it is the only option on the command line.

`-tape`

Display in the list only the images that have at least one fragment that resides on removable or tape-based media. Any disk-based fragments in these images are ignored. If an image has fragments on both tape and disk, this option displays only the tape-based fragments.

`-v`

Selects the verbose mode. This option causes `bpimagelist` to log additional information for debugging purposes. The information goes into the NetBackup administration daily debug log. This option is meaningful only when the debug log function is enabled; that is, when the following directory is defined:

`install_path\NetBackup\logs\admin`

EXAMPLES

Example 1

The first example shows the last time each media ID available to a server had a backup image that was written today:

```
bpimagelist -media -U
Media ID      Last Written      Server
-----
IBM000       01/06/2006 01:06  hatt
AEK800       01/06/2006 03:01  hatt
C0015        01/06/2006 02:01  hatt
```

Example 2

The following example shows the last time the media IDs available to the server had a backup image that was written during the specified time:

```
bpimagelist -media -d 01/05/2006 18:00:46 -e 01/06/2006 23:59:59 -U
```

Media ID	Last Written	Server
IBM000	01/06/2003 01:06	hatt
AEK800	01/06/2003 03:01	hatt
C0015	01/06/2003 02:01	hatt
143191	01/05/2003 23:00	hatt

Example 3

The following example lists all images that were written today:

```
bpimagelist -U
```

Backed Up	Expires	Files	KB	C	Sched	Type	Policy
01/27/2007 01:08	02/03/2007	1122	202624	N	Full	Backup	3590Grau
01/27/2007 01:01	02/03/2007	1122	202624	N	Full	Backup	IBM35pol
01/27/2007 03:01	02/03/2007	531	1055104	N	Full	Backup	DELLpol
01/27/2007 02:01	02/03/2007	961	31776	N	Full	Backup	QUALpol
01/27/2007 01:08	02/03/2007	2063	603328	N	Full	Backup	IBM35pol
01/27/2007 01:01	02/03/2007	2063	603328	N	Full	Backup	3590Grau

Example 3

The following example lists media written information for 01/05/2006:

```
bpimagelist -media -d 01/05/2006 -e 01/05/2006 -U
```

Media ID	Last Written	Server
IBM000	01/05/2006 01:13	hatt
143191	01/05/2006 23:00	hatt
AEK800	01/05/2006 03:07	hatt
C0015	01/05/2006 02:06	hatt

FILES

install_path\NetBackup\logs\admin\log.mmdyy
install_path\NetBackup\db\images

SEE ALSO

bparchive, bpbackup, bprestore

bpimmedia

NAME

bpimmedia - display information about NetBackup images on media

SYNOPSIS

```
install_path\NetBackup\bin\admincmd\bpimmedia -disk_stu
storage_unit_label | -dt disk_type | -stype server_type [-dp
disk_pool_name [-dv disk_volume]] [-l | -L] [-disk | -tape] [-policy
policy_name] [-client client_name] [-d date time] [-e date time]
[-mediaid media_id | path_name] [-mtype image_type] [-option
option_name] [-rl retlevel] [-sl sched_label] [-t sched_type]
[-legacy] [-M master_server...] [-verbose]

install_path\NetBackup\bin\admincmd\bpimmedia -spanpools [-cn
copy_number] [-mediaid media_id] [-U]
```

DESCRIPTION

bpimmedia queries the NetBackup image catalog and reports on the NetBackup images. bpimmedia produces two types of reports:

- An Images-on-Media report
- A Spanpools report

The first form of bpimmedia in the SYNOPSIS displays a set of NetBackup images in the Images-on-Media report. This report lists the contents of media as recorded in the NetBackup image catalog.

You can generate this report for any medium (including disk. Filter the report contents according to client, media ID, path, and so on.

Refer to the section on NetBackup Reports in the *NetBackup Administrator's Guide* for more information, including details about the fields in the Images-on-Media report.

The report does not show information for the media that is used in backups of the NetBackup catalogs.

Several new options (*-dt*, *-dp*, *-dv*, *-stype*) report images present on SAN disk storage only, not on any other disk-resident images. Other options and output format continue to function as before.

The second SYNOPSIS form of bpimmedia uses *-spanpools* to list the disk ID pools that are *related* because images span from one volume to another. The output lists, for each media server in the cluster, the media IDs that have

spanned images. The `-spanpools` form of `bpimmedia` must be run on the NetBackup master server that administers the volumes.

(See the Spanning Media topic in the *NetBackup Administrator's Guide*.)

Only removable media types are processed.

`bpimmedia` sends its error messages to `stderr`. `bpimmedia` sends a log of its activity to the NetBackup admin log file for the current day.

Authorized users can run this command.

For more information about NetBackup authorization, refer to the *NetBackup Security and Encryption Guide*.

OPTIONS

`-client client_name`

Client name. This name must be as it appears in the NetBackup catalog. By default, `bpimmedia` searches for all clients.

`-cn copy_number`

Copy number (1 or 2) of a backup ID. The default is copy 1. This option is used only in combination with `-spanpools`.

`-d date`

`-e date`

Specifies the start date and end date and time. They specify the time range during which an image must have been created to be included in the report.

`-d` specifies a start date and time. The resulting list shows only images from backups or the archives that occurred at or after the specified date and time. The format of `date` depends on the user's locale setting.

See the NOTES section later in this description for more information.

For the C locale, the date syntax is as follows:

```
mm/dd/yyyy [hh[:mm[:ss]]]
```

The valid range of dates is from 01/01/1970 00:00:00 to 01/19/2038 03:14:07. The default is the previous midnight.

`-e` specifies an end date and time. The resulting list shows only images from backups or the archives that occurred at or before the specified date and time range. Use the same format as the start date. The default is the current date and time.

`-dp disk_pool_name`

Displays the images on the specified disk pool only.

`-dt disk_type`

Specifies the type of disk storage. The following are valid options:

1 - BasicDisk

2 - NearStore

3 - SnapVault

This option does not apply to the OpenStorage disk type.

`-dv disk_volume`

Displays the images that reside on the specified disk volume only. The input value is the volume path for NearStore, the path for BasicDisk, and the volume name for SharedDisk.

`-help`

Prints a command line usage message when `-help` is the only option on the command line.

`-L`

The list type is long.

See [DISPLAY FORMATS](#) for more detail.

`-l`

The list type is short. This option is the default if the command line has no list-type option (for example, if you enter `bpimmedia` and a carriage return).

See [DISPLAY FORMATS](#) for more detail.

`-legacy`

Formats the new data in legacy format.

`-M master_server,...`

A list of alternative master servers. This list is a comma-separated list of hostnames. If this option is present, the command is run on each of the master servers in this list. The master servers must allow access by the system that issues the command. If an error occurs for any master server, the process stops at that point in the list. The default is the master server for the system where the command is entered.

`-mediaid media_id | pathname`

This ID is either a VSN or an absolute pathname. If the media ID is a VSN, it is a one- to six-character string. If the media ID is a pathname, it is the absolute pathname of the filesystem for a disk storage unit.

When `-mediaid` is specified, the Images-on-Media report displays only the images that are stored on this VSN or pathname. By default, the report displays the images that are stored on all media IDs and pathnames.

For the Spanpools report (`-spanpools`), only a VSN can follow `-mediaid`. If `-mediaid` is omitted when `-spanpools` is present, `bpimmedia` displays all media in all spanning pools.

`-mtype image_type`

Image type. The defined values and their interpretations are as follows:

- 0 = Regular backup (scheduled or user-directed backup)
- 1 = Pre-imported backup (phase 1 completed)
- 2 = Imported backup

`-option option_name`

Specifies a criterion for finding images to list. `option_name` is one of the following character strings, in either uppercase or lowercase:

- INCLUDE_PRE_IMPORT - Include images that completed phase one of an import.

Refer to the `bpimport` command description or the *NetBackup Administrator's Guide* for more information.

- ONLY_PRE_IMPORT - Include only the images that completed phase one of an import.

The default is INCLUDE_PRE_IMPORT.

`-policy policy_name`

Policy name. By default, `bpimmedia` searches for images for all policies.

`-rl retlevel`

Specifies the `retention_level`. The `retention_level` is an integer between 0 and 24. By default, `bpimmedia` searches for all retention levels.

`-sl sched_label`

The schedule label. By default, `bpimmedia` searches for images for all schedule labels.

`-spanpools`

Specifies that `bpimmedia` should create a Spanpools report. The default is to create an Images-on-Media report.

`-stype server_type`

A string that identifies the storage server type. Possible values are AdvancedDisk, OpenStorage (*vendorname*), PureDisk, and SharedDisk.

`-t sched_type`

Specifies a schedule type for the image selection. The default is any schedule type. Valid values, in either uppercase or lowercase, are as follows:

- FULL (full backup)
- INCR (differential-incremental backup)
- CINC (cumulative-incremental backup)
- UBAK (user backup)
- UARC (user archive)

-tape

Display in the Images-on-Media report only the images that have at least one fragment that resides on removable or tape-based media. Any disk-based fragments in these images are ignored. If an image has fragments on both tape and disk, this option displays only the tape-based fragments.

-U

The list type is user. This option is used only in combination with `-spanpools`.

See [DISPLAY FORMATS](#) for more detail.

-verbose

Select verbose mode for logging. This option is only meaningful when it runs with debug logging on; that is, when the following directory is defined:

```
install_path\NetBackup\logs\admin
```

DISPLAY FORMATS

IMAGES-ON-MEDIA REPORT

The Images-on-Media report consists of two formats, short (`-l` or default) and long (`-L`).

Note, if you want to process and use the output of `bpimmedia`, we recommend that you use the `-l` option. The output of `bpimmedia` that uses the `-L` or `-U` options may be truncated for the Backup-ID, Policy, and Host columns. The `-L` or `-U` options are useful when you want to obtain a quick, more readable view of the NetBackup images on media.

■ Long Display Format (`-L`)

If the command line contains `-L`, the display format is long. The `-L` display format contains a multi-line entry for each backup image. `n+1` is the number of lines for an entry, where `n` is the number of fragments for the image. The fields for an entry are listed later. The first line of the entry contains the fields Backup_ID...Expires. Each fragment in the image has a line that contains the fields Copy_Media ID. The report has a two-line header. The first header line lists the field names for line 1 of each entry. The second header line lists the field names for the lines that contain fragment information.

See the `bpduplicate` command page for more information on the terms *copy number* and *primary copy*.

Fields and meanings for the `-L` format are as follows:

Line 1

Backup-ID - Unique identifier for the backup that produced this image
Policy - Policy name (may be truncated if long)

Type - Schedule type (FULL, etc.)

RL - Retention level (0..24)

Files - Number of files in the backup

C - Compression (Y or N)

E - Encryption (Y or N)

T - Image type

R - Regular (scheduled or user-directed backup)

P - Pre-imported backup (phase 1 completed)

I - Imported backup

PC - Primary copy, 1 or 2. Designates which copy of the backup NetBackup chooses when it restores.

Expires - The expiration date of the first copy to expire, which appears in the Expires field of the fragment, which is described later

Line 2_n+1

Copy - Copy number of this fragment

Frag - Fragment number, or IDX for a true-image-restore (TIR) fragment

KB - Size of the fragment, in kilobytes. This value does not include the size of tape headers between backups. A fragment size of 0 is possible for a multiplexed backup.

Type - Media type (Rmed - removable media; Disk otherwise)

Density - Density of the device that produced the backup (applies only to removable media)

Fnum - File number; the n-th backup on this medium (applies only to removable media)

Off - The byte offset on the medium where the backup begins (applies only to optical disk; ignore this value for tapes and magnetic disk)

Host - Server whose catalog contains this image

DWO - Device Written On; device where the backup was written. The DWO matches the drive index as configured in Media Manager (applies only to removable media).

MPX - Flag that indicates whether this copy is multiplexed: Y or N (applies only when fragment number is 1)

Expires - The expiration date of this copy (applies only when fragment number is 1)

MediaID - Media ID or absolute path where the image is stored

Example of Long display format:

```
bpimmedia -L -policy regr1_gava -t FULL
Backup-ID      Policy      Type  RL  Files  C  E  T  PC  Expires
Copy Frag  KB Type Density FNum Off Host DWO MPX Expires MediaID
-----
gava_0949949902 regr1_guav FULL  3   25  N  N  R  1  12:58 03/09/2003
```

```
1 1 256 RMed dlt 13 0 plim 0 Y 12:58 03/09/2002
A00002
```

■ Short Display Format (-l)

If the `bpconfig` command line contains `-l` or contains no list-format option, the display format is short, which produces a terse listing. This option can be useful for scripts or the programs that rework the listing into a customized report format. The `-l` display format contains a multi-line entry for each backup image. `n+1` is the number of lines for an entry, where `n` is the number of fragments for the image. The layout of an entry is a first line that contains information about the image. A second line follows that contains information about each fragment of the image. The attributes appear in the following order (separated by blanks).

Fields for the `-l` format are as follows:

Line 1

IMAGE - Identifies the start of an image entry
 Client - Client for the backup that produced this image
 Version - Image-version level
 Backup-ID - Unique identifier for the backup that produced this image
 Policy - Policy name
 Policy type - 0 denotes Standard, etc. Run `bpimmedia -L` or refer to `bpbackup (1M)` to interpret the policy-type value as a policy-type name.
 Schedule - Schedule name
 Type - Schedule type (full, etc.)
 RL - Retention level (0-24)
 Files - Number of files
 Expiration date or time - The expiration date of the first copy to expire. It appears in the Expires field of the fragment, which is described later (system time). 0 denotes an image in progress or failed.
 C - Compression; 1 (yes) or 0 (no)
 E - Encryption; 1 (yes) or 0 (no)

Line 2_n+1

FRAG - Identifies a fragment line in an image entry
 Copy - Copy number of this fragment
 Frag - Fragment number, or -1 for a TIR fragment
 KB - Size of the fragment in kilobytes
 MPX - Flag that indicates whether this copy is multiplexed, 1(yes) or 0(no) (applies only when fragment number is 1)
 Expires - The expiration date of this copy in system time (applies only when fragment number is 1)
 Disk type - BasicDisk (1), NearStore (2), SAN Disk (4)

Disk pool name - Only applies to SAN Disk. All other disk types show *NULL*.

Media ID - volume path if NearStore, path if BasicDisk, or volume name if SAN Disk

Density - Density value (applies only to removable media). Run `bpimmedia -L` or `bpmedialist -m list -L -m mediaid` to interpret the density value as a density label

Fnum - File number; the n-th backup on this medium (applies only to removable media)

MediaID - Media ID or absolute path where the image is stored

Host - Server whose catalog contains this image

Block size - Number of kilobytes per block for this medium

Off - Offset

Media date - Time this medium was allocated (system time)

DWO - Device Written On (applies only to removable media)

Example of the short display format:

```
bpimmedia -l -policy regr1_gava -t FULL
IMAGE gava 3 gava_0949949902 regr1_gava 0 full 0 3 25 952628302 0 0
FRAG 1 1 10256 512 2 13 13 A00002 plim 65536 0 949616279 0 0 *NULL* 952628302 1
```

SPANPOOLS REPORT

The Spanpools report has two formats: user (-U option) and short (the default). Both formats list, for each server, the server name, and the pool data for that server. For each pool of media that share backup images that are spanned, the media IDs are listed. When `-mediaid` appears on the command line, only the server pool and the disk pool that are related to that media ID appear.

Note, if you want to process and use the output of `bpimmedia`, we recommend that you use the `-l` option. The output of `bpimmedia` that uses the `-U` or `-L` options may be truncated for the Backup-ID, Policy, and Host columns. The `-U` or `-L` options are useful when you want to obtain a quick, more readable view of the NetBackup images on media.

The user (-U) display format looks like the following:

```
bpimmedia -spanpools -U
Related media pools containing spanned backup images, server plim:
Pool:
  A00002  A00003
Pool:
  400032
```

The short display format looks like the following

```
bpimmedia -spanpools
SERVER plim
POOL A00002 A00003
```

POOL 400032

NOTES

The format that you must use for date and time values in NetBackup commands varies according to your locale setting.

If you are uncertain of the NetBackup command requirements for your locale, enter the command with the `-help` option and check the USAGE. The following is part of the usage statement for `bpimmedia` that shows the `-d` and `-e` options:

```
[ -d mm/dd/yyyy hh:mm:ss ] [ -e mm/dd/yyyy hh:mm:ss ]
```

Notice the month/day/year and hours:minutes:seconds requirements for the `-d` and `-e` options. These are for a locale setting of C and can be different for other locales.

EXAMPLES

Example 1

List the images for policy `c_NDMP`. This request runs on a NetBackup media server. The report is based on the image catalog on the media server's master server, `almond`.

```
bpimmedia -L -policy c_NDMP
```

Backup-ID	Policy	Type	RL	Files	C	E	T	PC	Expires	MediaID
Copy Frag	KB	Type	Density	FNum	Off		Host	DWO MPX	Expires	MediaID

t_0929653085	c_NDMP	FULL	3	5909	N	N	R	1	15:58 07/18/2004	
1	IDX	844	RMed dlt	2	0		almond	3		CB7514
1	1	9136	RMed dlt	1	0		almond	3	N 15:58 07/18/2004	
CB7514										

■ Example 2

The following example displays the tapes that are required to restore a particular file. If the `bpimmedia` command line provides the criteria to identify an individual backup, the output shows the media that was used for the backup.

In this case, the command line provides the client, the date of the backup and the schedule type. The output shows that tape `A00002` on the server `plim` contains the backup.

```
bpimmedia -L -client gava -d 2/7/2002 -t UBAK
```

Backup-ID	Policy	Type	RL	Files	C	E	T	PC	Expires	MediaID
Copy Frag	KB	Type	Density	FNum	Off		Host	DWO MPX	Expires	MediaID

```
gava_0949949686      regr1_guav UBAK 3 25      N N R 1 12:54 03/09/2004
 1 1 10256 RMed dlt 11 0      plim 0 Y 12:54 03/09/2004
A00002
```

Example 3

List in long format all the backups in the image catalog on the master server gava.

```
bpimmedia -L -M gava
```

```
Backup-ID          Policy          Type  RL  Files  C  E  T  PC  Expires
Copy Frag        KB Type Density FNum    Off    Host    DWO MPX Expires  MediaID
-----
gava_0949599942    test-policy FULL  1  15      N N R 1 11:45 02/17/2004
 1 1 224 Disk - - -      gava - N 11:45 02/17/20
/var/qatest/storage_unit//gava_0949599942_C1_F1
```

Example 4

List in long format the backups on media ID CB7514.

```
bpimmedia -L -mediaid CB7514
```

```
Backup-ID          Policy          Type  RL  Files  C  E  T  PC  Expires
Copy Frag        KB Type Density FNum    Off    Host    DWO MPX Expires  MediaID
-----
toaster1_0929679294  tort_policy FULL  3  5898    N N R 1 23:14 07/18/2004
 1 IDX 839 RMed dlt 4 0      almond 6 CB7514
 1 1 27154 RMed dlt 3 0      almond 6 N 23:14 07/18/2004
CB7514

toaster1_0929653085  NDMP_policy FULL  3  5909    N N R 1 15:58 07/18/2004
 1 IDX 844 RMed dlt 2 0      almond 3 CB7514
 1 1 9136 RMed dlt 1 0      almond 3 N 15:58 07/18/2004
CB7514
```

RETURN VALUES

An exit status of 0 means that the command ran successfully.

Any exit status other than 0 means that an error occurred.

If the administrative log function is enabled, the exit status is logged in the administrative daily log under the log directory:

```
install_path\NetBackup\logs\admin
```

It has the following form:

```
bpimmedia: EXIT status = exit status
```

If an error occurred, a diagnostic precedes this message.

FILES

install_path\NetBackup\logs\admin*
install_path\NetBackup\db\images

SEE ALSO

bpbackup, bpduplicate, bpimport

bpimport

NAME

`bpimport` - import NetBackup and Backup Exec backups that are expired or are from another NetBackup or Backup Exec server

SYNOPSIS

```
install_path\NetBackup\bin\admincmd\bpimport -create_db_info -id media_id  
or path | -stype server_type [-dp disk_pool_name [-dv disk_volume]]  
[-server name] [-L output_file [-en]] [-passwd] [-local] [-nh  
ndmp_host [-mst media_subtype]]
```

```
install_path\NetBackup\bin\admincmd\bpimport [-l] [-p] [-pb] [-PD] [-PM]  
[-v] [-local] [-client name] [-M master_server] [-Bidfile file_name]  
[-st sched_type] [-sl sched_label] [-L output_file [-en]] [-policy  
name] [-s startdate] [-e enddate] [-pt policy_type] [-hoursago hours]  
[-cn copy_number] [-backupid backup_id] [[-id media_id | path] |  
-stype server_type]] [-dp disk_pool_name [-dv disk_volume]]
```

DESCRIPTION

The `bpimport` command allows backups to be imported. This command is useful for importing expired backups or the backups from another NetBackup server.

The import operation consists of the following two steps:

- Step 1 is performed with the first form of the command that appears in the Synopsis (`-create_db_info` option). This step recreates catalog entries for the backups that are on the specified media.
- Step 2 is performed with the second form of the command that appears in the Synopsis. This step imports the backups from the media.

The expiration date for imported backups is the current date plus the retention period. For example, if a backup is imported on 14 November 2006 and its retention level is one week, its new expiration date is 21 November 2006.

You can import a backup only if all copies of it are expired.

For more information on how to import backups, see the *NetBackup Administrator's Guide*.

Authorized users can run this command.

For more information about NetBackup authorization, refer to the *NetBackup Security and Encryption Guide*.

OPTIONS

- `-backupid backup_id`
Specifies the backup ID of a single backup to import.
- `-Bidfile file_name`
file_name specifies a file that contains a list of backup IDs to import. List one backup ID per line in the file. If this option is included, other selection criteria is ignored.
In addition, NetBackup removes the file that is specified with the `-Bidfile` parameter during the activation of that command line interface (CLI). It is removed because the NetBackup GUIs commonly use this parameter. The GUIs expect the command-line interface to remove the temporary file that was used for the `-Bidfile` option upon completion. Direct command-line interface users can also use the option, however it removes the file.
- `-client name`
The host name of the client for which the backups were performed. The default is all clients.
- `-cn copy_number`
Specifies the source copy number of the backups to import. Valid values are 1 through 10. The default is all copies.
- `-create_db_info`
This option recreates catalog entries for the backups that are on the specified media. It skips the backups that are already in the catalog. This option only creates information about the backups that are candidates for import, and does not perform the import operation. The `bpimport` command must be run with this option before you import any backups.
- `-dp disk_pool_name [-dv disk_volume]`
Imports images on the specified disk pool only. Optionally, the import can be restricted to the images that reside on the specified disk volume only. The *disk_volume* argument is the volume path for NearStore, the path for BasicDisk, and the volume name for SharedDisk.
Option `-stype` is required with this option.
- `-e enddate`
- `-s startdate`
The default for the end date is the current date and time. The default for the start date is 24 hours before the current date and time.
- `-hoursago hours`
Specifies the number of hours to search before the current time for backups. Do not use with the `-s` option. The default is the previous midnight.

`-id media_id | path`

Disk media:

Specifies the *path* to the storage directory that contains the backup to be imported.

Tape media:

For step 1 (`-create_db_info`), this option specifies the media ID that has the backups you plan to import. This option is required with `-create_db_info`.

For step 2, this option designates a specific media ID from which to import backups. The default is all media IDs that were processed in step 1 of the import operation.

A backup ID that begins on a media ID that is not processed by step 1 does not import (the backup is incomplete).

`-L output_file [-en]`

Specifies the name of a file in which to write progress information. The default is not to use a progress file.

Include the `-en` option to generate a log in English. The name of the log contains the string `_en`. This option is useful to support the personnel that assist in a distributed environment where different locales may create logs of various languages.

`-l`

Produces the output in the progress log that lists each imported file.

`-local`

When a host other than master server initiates `bpimport` and `-local` is *not* used (default), the following occurs: `bpimport` starts a remote copy of the command on the master server.

The remote copy allows the command to be terminated from the Activity Monitor.

Use `-local` to prevent the creation of a remote copy on the master server. You also can use it to run the `bpimport` only from the host where it was initiated.

If the `-local` option is used, `bpimport` cannot be canceled from the Activity Monitor.

`-M master_server`

Note: This option is not required for NetBackup Server because it has only one server, the master. If you do use this option in this case, specify the NetBackup master where you run the command.

Specifies the master server that manages the media catalog that has the media ID. If this option is not specified, the default is one of the following:
If the command is run on a master server, then that server is the default.
If the command is run on a media server that is not the master, then the master for that media server is the default.

-p

Previews backups to import according to the option settings, but does not perform the import. Displays the media IDs, server name, and information about the backups to import.

-passwd

Use with the Backup Exec tape reader option to catalog password-protected Backup Exec media. When `-passwd` is specified, `bpimport` prompts the user for a password. The given password is then compared with the password on the media. If the password matches, the job proceeds. If the password does not match, the job fails.

Use `-passwd` only when Backup Exec media is imported and the Backup Exec media are password-protected. Backup Exec media can only be imported on a Windows media server.

-pb

Previews the backups to import but does not perform the import. Similar to the `-p` option, but does not display the backups.

-PD

Same as the `-PM` option, except the backups sort by date and time (newest to oldest).

-PM

Displays the information on the backups to be imported according to the option settings, but does not perform the import. It displays the following information about the backup: date and time of the backup, policy, schedule, backup ID, host, and media ID.

-policy *name*

Search for backups to import in the specified policy. The default is all policies.

-pt *policy_type*

Search for the backups that the specified policy type created. The default is any policy type.

Valid values are:

Informix-On-BAR

MS-Exchange-Server

MS-SharePoint

MS-SQL-Server

MS-Windows

NDMP

NetWare

Oracle

OS/2

Standard

Sybase

Note that the following policy types apply only to NetBackup Enterprise Server:

AFS

DataTools-SQL-BackTrack

DB2

FlashBackup

SAP

Split-Mirror

-server *name*

Note: The NetBackup Server has only one server (the master). When you use NetBackup Server, specify the name of that server.

Specifies the name of the media server. The volume database for this server must have a record of the media ID that contains the backups to import. The default is the media server where the command is run.

-sl *sched_label*

Search for backups to import that the specified schedule created. The default is all schedules.

-st *sched_type*

Search for backups to import that the specified schedule type created. The default is any schedule type.

Valid values are as follows:

FULL (full backup)

INCR (differential-incremental backup)

CINC (cumulative-incremental backup)

UBAK (user backup)

UARC (user archive)

NOT_ARCHIVE (all backups except user archive)

`-stype server_type`

A string that identifies the storage server type. Possible values are AdvancedDisk, OpenStorage (*vendorname*), PureDisk, and SharedDisk.

`-v`

Selects the verbose mode. When you specify, the debug and progress logs display more information.

EXAMPLES

Example 1

The following command (all on one line) creates catalog information for backups on media ID A00000. The media host hostname is cat. The progress file is `bpimport.ls`, which is located in the `tmp` directory.

```
bpimport -create_db_info -id A00000 -server cat -L \tmp\bpimport.ls
```

Example 2

The following command (all on one line) displays information about the backups that are candidates for import. The backups that appear were created between 11/01/2006 and 11/10/2006. The `bpimport` command with the `-create_db_info` option must be run before this command.

```
bpimport -PM -s 11/01/2006 -e 11/10/2006
```

Example 3

The following command imports the backups that were specified in the `\tmp\import\images` file. The progress is entered in the `\tmp\bpimport.ls` file.

```
bpimport -Bidfile \tmp\import\image -L \tmp\bpimport.ls
```

FILES

```
install_path\NetBackup\logs\admin\*
```

```
install_path\NetBackup\db\images\*
```

bpinst

NAME

`bpinst` - install and configure NetBackup Encryption

SYNOPSIS

```
install_path\NetBackup\bin\bpinst -ENCRYPTION [-force_install] [-verbose]  
[-policy_names] name1 [name2 ... nameN]
```

```
install_path\NetBackup\bin\bpinst -LEGACY_CRYPT [-update_libraries]  
[-crypt_option option][-crypt_strength strength] [-passphrase_prompt  
|-passphrase_stdin] [-verbose] [ [-policy_encrypt 0 | 1]  
-policy_names] name1 [name2 ... nameN]
```

Note: To use this command you must have NetBackup Encryption, a separately priced product.

DESCRIPTION

NetBackup Encryption provides file-level encryption of backups and archives. The two versions are as follows:

- `-ENCRYPTION` is the Standard Encryption method (recommended)
Provides the ability to encrypt data that uses 128-bit OpenSSL ciphers or 256-bit OpenSSL ciphers.
- `-LEGACY_CRYPT` is the Legacy Encryption method
Provides the user with the encryption strength choices previously available (40-bit DES and 56-bit DES).

The `bpinst` command (used with `-LEGACY_CRYPT` or `-ENCRYPTION` option) installs and configures the NetBackup Encryption product on the NetBackup clients that can support encryption.

Before you use this command, install the encryption software on the server as explained in the *NetBackup Security and Encryption Guide*. Then, activate `bpinst -LEGACY_CRYPT` or `-ENCRYPTION` on the master server to install and configure NetBackup Encryption on the clients. A single activation copies the required files to the selected clients. It also makes the necessary configuration changes on both the clients and the master server.

Note: Ensure that the `DISALLOW_SERVER_FILE_WRITES` NetBackup configuration option is not set on the client. If this option is set, the server cannot install and configure the software on the client.

See the `OPTIONS` section for an explanation of all options that used with `bpinst -ENCRYPTION` or `-LEGACY_CRYPT`. (Pay special attention to the `-passphrase_prompt` option.)

Note: You can also configure encryption for a client that is installed on the master server host.

Any authorized user can run this command.

For more information about NetBackup authorization, refer to the *NetBackup Security and Encryption Guide*.

OPTIONS

The following options apply to the `-ENCRYPTION` command.

`-ENCRYPTION`

Required if you use 128-bit OpenSSL ciphers or 256-bit OpenSSL ciphers. To use the `bpinst` command to install or configure Cipher-based encryption, specify this option first. The order is important; do not omit this option.

`-force_install`

Installs the encryption client files on the specified UNIX and Linux clients without checking the version of any existing files on the client machines. This option does nothing on Windows clients, because encryption client files are already pre-installed on them.

`-policy_names`

Specifies that the names you specify with the `names` option are NetBackup policy names.

If you include the `-policy_names` option, `bpinst -LEGACY_CRYPT` or `-ENCRYPTION` installs and configures all the clients in each policy you specify.

If you omit the `-policy_names` option, the names are assumed to be NetBackup client names.

`name1 [name2 ... nameN]`

One or more NetBackup client or policy names, depending on whether you included the `-policy_names` option. If you omit the `-policy_names` option, the names are assumed to be NetBackup client names.

`-verbose`

Prints the current encryption configuration of each client and what gets installed and reconfigured on each client.

The following options apply to the `-LEGACY_CRYPT` command.

`-LEGACY_CRYPT`

Required if you use 40-bit DES or 56-bit DES encryption. To install or configure DES encryption, specify this option first to use the `bpinst` command `t`. The order is important; do not omit this option.

`-update_libraries`

Installs the encryption libraries on NetBackup clients. This option applies to the `-LEGACY_CRYPT` option only.

`-crypt_option option`

Configures the `CRYPT_OPTION` configuration entry on the NetBackup clients. If you do not specify `-crypt_option`, the client allows either encrypted or unencrypted backups (see `ALLOWED`).

The possible values for *option* are:

`DENIED | denied | -1`

Specifies that the client does not permit encrypted backups. If the server requests an encrypted backup, it is considered an error. This option is the default for a client that has not been configured for encryption.

`ALLOWED | allowed | 0`

Specifies that the client allows either encrypted or unencrypted backups. The default.

`REQUIRED | required | 1`

Specifies that the client requires encrypted backups. If the server requests an unencrypted backup, it is considered an error.

`-crypt_strength strength`

Configures the `CRYPT_STRENGTH` configuration entry on the NetBackup clients. If you do not specify this option, the `CRYPT_STRENGTH` configuration entries on the clients remain unchanged.

The possible values for *strength* are:

`DES_40 | des_40 | 40`

Specifies the 40-bit DES encryption. This value is the default value for a client that has not been configured for encryption.

`DES_56 | des_56 | 56`

Specifies the 56-bit DES encryption.

`-passphrase_prompt` | `-passphrase_stdin`

Note: Do not forget the pass phrase. If the key file is damaged or lost, you may need the pass phrase to regenerate the key file. Without the proper key file, you cannot restore encrypted backups.

NetBackup uses a pass phrase to create the data that it places in a key file on each client. NetBackup then uses the data in the key file to create the encryption keys that are required to encrypt and decrypt the backup data. This option applies to the `-LEGACY_CRYPT` option only.

The `-passphrase_prompt` option prompts you to enter a pass phrase. The actual pass phrase is hidden while you type.

The `-passphrase_stdin` option reads the pass phrase through standard input. You must enter the pass phrase twice. This option is less secure than the `-passphrase_prompt` option because the pass phrase is not hidden. However, it may be more convenient if you use `bpinst -LEGACY_CRYPT` in a shell script.

NetBackup uses the pass phrase for all the clients that you specify on the `bpinst -LEGACY_CRYPT` command. If you want separate pass phrases for each client, enter a separate `bpinst -LEGACY_CRYPT` command for each client.

When you specify a pass phrase, `bpinst -LEGACY_CRYPT` creates or updates the key files on the clients. The encryption keys (generated from the pass phrase) are used for subsequent backups. Old encryption keys are retained in the key file to allow restores of previous backups.

If you do not specify either the `-passphrase_prompt` or `-passphrase_stdin` option, the key files on the clients remain unchanged.

`-verbose`

Prints the current encryption configuration of each client and what gets installed and reconfigured on each client.

`-policy_encrypt 0` | `1`

Sets the Encryption policy attribute for the NetBackup policies. You can include `-policy_encrypt` only with the `-policy_names` option. The possible values are:

0 - clears the Encryption attribute (or leaves it clear) so the server does not request encryption for clients in this policy. The default for the policies that are not configured for encryption.

1 - sets the Encryption attribute so the server requests encryption for clients in this policy.

If you do not specify this option, the Encryption attributes for the policies remain unchanged.

`-policy_names`

Specifies that the names you specify (with the `names` option) are NetBackup policy names.

If you include the `-policy_names` option, `bpinst -LEGACY_CRYPT` or `-ENCRYPTION` installs and configures all the clients in each specified policy.

If you omit the `-policy_names` option, the names are assumed to be NetBackup client names.

`name1 [name2 ... nameN]`

One or more NetBackup client or policy names, depending on whether you have included the `-policy_names` option. If you omit the `-policy_names` option, the names are assumed to be NetBackup client names.

NOTES

The following list of notes applies to both the `-ENCRYPTION` and the `-LEGACY_CRYPT` option.

For additional information about NetBackup encryption, refer to the *NetBackup Encryption Administrator's Guide*.

- If you are running NetBackup in a clustered environment, you can push software to the client only from the active node.
- If you push the encryption software to clients that are located in a cluster, do the following: specify the hostnames of the individual nodes (not virtual names) in the clients list.
- In a clustered environment, after you have successfully installed the add-on, unfreeze the node.
- When you finish the restore of encrypted files from a client, rename or delete the key file created. Move or rename your own key file to its original location or name. If you do not re-establish your key file to its original location or name, you may not be able to restore your own encrypted backups.
- Existing 40-bit encryption license keys or 56-bit encryption license keys are valid for upgrades.

The following list of notes applies to the `-LEGACY_CRYPT` option only.

- A privately defined NetBackup 40-bit DES key encrypts the pass phrase that `bpinst -LEGACY_CRYPT` sends over the network.

- The key file on each NetBackup client is encrypted with a privately defined NetBackup DES key. The key can be 40 bit or 56 bit, depending on how the client is configured. Restrict access to the key file to the administrator of the client machine. On a UNIX client, the owner of the key file should be root and the mode bits should be 600. The key file should not be exportable through NFS.
- The key file must be the same on all nodes in a cluster.
- Remember pass phrases. In a disaster recovery situation, you may have to recreate a key file on a client by using `bpinst -LEGACY_CRYPT`. For example, suppose a NetBackup client that is named `orca` performs encrypted backups and an accident occurs that causes `orca` to lose its files. In this case you must reinstall and configure encryption on the client to restore your backups.

The following is a procedure for disaster recovery when you use encryption. See the *NetBackup Troubleshooting Guide* for details on how to restore the operating system and NetBackup).

This example assumes a NetBackup client that is named `orca`.

- 1 Reinstall the operating system on `orca`.
- 2 Reinstall and configure the NetBackup client software on `orca`.
- 3 Reinstall and configure encryption on `orca` by activating the following command (one line):

```
bpinst -LEGACY_CRYPT -update_libraries -crypt_option allowed
```

- 4 Activate `bpinst -LEGACY_CRYPT` to create a pass phrase.

```
bpinst -LEGACY_CRYPT -passphrase_prompt orca
Enter new NetBackup pass phrase: *****
Re-enter new NetBackup pass phrase: *****
```

The pass phrase that you enter here is the first one used on `orca`.

- 5 Activate `bpinst -LEGACY_CRYPT` for each subsequent pass phrase that is used on `orca`:

```
# bpinst -LEGACY_CRYPT -passphrase_prompt orca
Enter new NetBackup pass phrase: *****
Re-enter new NetBackup pass phrase: *****
```

- 6 Restore the backed up files to `orca`.

EXAMPLES

Example 1

The following command copies encryption software from a master server to NetBackup clients.

From a Master Server

Assume that you want to install the encryption software on `client1` and `client2`. You enter a command like the following (all on one line):

```
bpinst.exe -ENCRYPTION client1 client2
```

Assume that you want to install the encryption software on all clients in the NetBackup policies `policy1` and `policy2`. You enter a command like the following (all on one line):

```
bpinst.exe -ENCRYPTION -policy_names policy1 policy2
```

Example 2

The following command installs the libraries on a NetBackup client that is named `mars` (one line):

```
bpinst.exe -LEGACY_CRYPT -update_libraries mars
```

Example 3

The following command (all on one line) installs and configures 40-bit DES encryption on UNIX clients in a policy named `policy40`:

```
bpinst -LEGACY_CRYPT -update_libraries -crypt_option allowed  
-crypt_strength des_40 -policy_encrypt 1
```

```
bpinst -LEGACY_CRYPT -passphrase_prompt -policy_names policy40  
Enter new NetBackup pass phrase: *****  
Re-enter new NetBackup pass phrase: *****
```

The preceding command uses the `-policy_encrypt` option to set the Encryption attribute for the policy. You can also use the NetBackup administrator utility to set the Encryption attribute.

Example 4

The following command (all on one line) specifies that the NetBackup client named `strong` must use 56-bit DES encryption:

```
bpinst -LEGACY_CRYPT -crypt_option required -crypt_strength des_56  
strong
```

Example 5

The following command displays a verbose listing of the configuration for the client named `strong`:

```
bpinst -LEGACY_CRYPT -verbose strong  
BPCD protocol version 4.5.0 on client strong  
40-bit library version is 3.1.0.40 on client strong  
56-bit library version is 3.1.0.56 on client strong  
BPCD platform is sgi5 for client strong  
Current configuration entries are:  
CRYPT_KEYFILE = /usr/opensv/netbackup/keyfile  
CRYPT_LIBPATH = /usr/opensv/lib  
CRYPT_OPTION = required  
CRYPT_STRENGTH = des-56  
No update of NetBackup configuration required for client strong  
No update of NetBackup pass phrase required for client strong
```

FILES

Windows:

- Windows server command

install_path\NetBackup\bin\bpinst.exe

- Windows server directory with encryption software

install_path\lib\client\

- Windows client encryption key file

install_path\NetBackup\var\keyfile.dat

- Windows client encryption libraries

install_path\bin\libvdes*.dll

- Windows client encryption key file utility

install_path\bin\bpkeyfile.exe

install_path\share\ciphers.txt

install_path\share\version_crypt.txt

bpkeyfile

NAME

`bpkeyfile` - run the legacy key file utility that is used for NetBackup standard encryption

SYNOPSIS

```
bpkeyfile [-stdin] [-change_key_file_pass_phrase]
          [-change_netbackup_pass_phrase] [-display] key_file_path
```

AVAILABILITY

The `bpkeyfile` command is available only with the NetBackup Encryption option.

DESCRIPTION

`bpkeyfile` creates or updates a file that contains the information that is used to generate DES encryption keys. The information is generated based on a NetBackup phrase that you supply. You supply a key-file pass phrase to encrypt the key file.

NetBackup client software uses an encryption key that is calculated from the key file information to encrypt files during backups or decrypt files during restores.

If the file exists, you are prompted to enter the current key-file pass phrase.

If you specify `-change_key_file_pass_phrase`, you are prompted for a new key file-pass phrase. If you enter an empty pass phrase, a standard key-file pass phrase is used.

If you use the standard key-file pass phrase, `bpcd` runs automatically. If you use your own key-file pass phrase, start `bpcd` with the `-keyfile` argument as explained in the *NetBackup Encryption Administrator's Guide*.

OPTIONS

`-stdin`

Read pass phrases from standard input. By default, `bpkeyfile` reads the pass phrases that you are prompted to input from your terminal window.

`-change_key_file_pass_phrase` (or `-ckfpp`)

Change the pass phrase that is used to encrypt the key file.

`-change_netbackup_pass_phrase` (or `-cnpp`)

Change the pass phrase that is used to encrypt NetBackup backups and archives on this client.

`-display`

Display information about the key file.

key_file_path

The path of the key file that `bpkeyfile` creates or updates.

NOTES

The pass phrases that NetBackup uses by can be from 0 to 63 characters long. To avoid compatibility problems between systems, restrict the characters in a pass phrase to printable ASCII characters. Space character (code 32) to tilde character (code 126).

The `bpkeyfile` command is used for legacy encryption.

FILES

Windows:

install_path\NetBackup\bin\keyfile.dat

(Windows client encryption key file)

bpkeyutil

NAME

`bpkeyutil` - run the key file utility that is used for NetBackup standard encryption

SYNOPSIS

```
install_path\NetBackup\bin\bpkeyutil [-stdin | -insert | -delete]  
[-display] [-client client_name1[,client_name2,...]] [-M server]
```

AVAILABILITY

The `bpkeyutil` command is available only with the NetBackup Encryption option.

DESCRIPTION

The `bpkeyutil` command updates a key file that contains the keys that are used for encryption and decryption. The keys are generated based on private *NetBackup pass phrases* that you supply. The key file is encrypted by using a key. The NetBackup client software uses an encryption key from the key file to encrypt files during a backup or decrypt files during a restore.

OPTIONS

`-stdin`

Read pass phrases from standard input. By default, `bpkeyutil` reads pass phrases that you are prompted to input from your terminal window.

`-insert`

Insert a new NetBackup pass phrase to the key file to encrypt NetBackup backups and archives on this client.

`-delete`

Delete an existing pass phrase from the key file.

`-display`

Display information about the key file.

`-client client_name1[,client_name2,...,client_namen]`

Name of the client where the key file resides. The default is the local client. You may specify multiple client names, separated by commas. You can only use this argument if you are a NetBackup administrator.

`-M server`

Name of the master server of the client. The default is the master server defined in the local client's configuration. You can only use this argument if you are a NetBackup administrator on the specified master server.

NOTES

- The `bpkeyutil` command is used for standard encryption.
- The key file must be the same on all nodes in a cluster.

FILES

`install_path\NetBackup\var\keyfile.dat`
(Windows client encryption key file)

bplabel

NAME

bplabel - write NetBackup label on tape media

SYNOPSIS

```
install_path\netbackup\bin\admincmd\bplabel -m media_ID -d density [-o]
[-p volume_pool_name] [-n drive_name | -u device_number] [-host
media_server] [-erase [-l]]
```

DESCRIPTION

The `bplabel` command writes a NetBackup label on the specified media. Labels are required only for the media that were last used for NetBackup catalog backups or by a non-NetBackup application. You can use this command to erase and label the media that is unassigned in a volume database. In addition, you can use this command to assign specific media IDs. The NetBackup Device Manager daemon or service (`ltid`) must be active for `bplabel` to succeed. You also must manually assign the drive by using the NetBackup Device Monitor unless you include the `-u` option on the `bplabel` command.

Caution: Ensure that the media does not contain required backups. After the media is relabeled, any backups that were on it cannot be restored.

Any authorized user can run this command.

For more information about NetBackup authorization, refer to the *NetBackup Security and Encryption Guide*.

The following are some facts about how to use this command:

- The `-m` and `-d` options are required.
- The `-p` option is required if the media ID is not in the NetBackup volume pool.
- If the data on the media is in a recognized format and the `-o` option is not specified, `bplabel` prompts you to confirm the overwrite. Data format recognition works only if the first block on a variable length media is less than or equal to 32 kilobytes.
- Use the `bplabel` command only for tapes.

You must have administrator privileges to run this command.

OPTIONS

-m *media_ID*

A required option that specifies the external media ID that is written to the tape label as a media ID . You can enter the media ID in either uppercase or lowercase. Internally, it always converts to uppercase. The media ID must be six or fewer alphanumeric characters.

-d *density*

A required option that specifies the density of the tape drive on which the media is mounted. The tape mount request must be performed on a drive type that satisfies the -d option.

Note: Do not use capital letters when you enter the density. Incorrect density syntax causes the command to fail and an "Invalid Density Drive Type" message to appear.

The valid densities are as follows:

4mm (4-mm Cartridge)

8mm (8-mm Cartridge)

d1t (DLT Cartridge)

hcart (1/2 Inch Cartridge)

qscsi (1/4 Inch Cartridge)

-o

Unconditionally overwrites the selected media ID. If this option is not specified, `bplabel` prompts for permission to overwrite the media that meets any of the following conditions:

Contains a NetBackup media header.

Is a NetBackup catalog backup media.

Is in TAR, CPIO, DBR, AOS/VS, or ANSI format.

-p *volume_pool_name*

This option is required if the media ID is defined in the Enterprise Media Manager Database but is not in the NetBackup volume pool.

volume_pool_name must specify the correct pool.

-u *device_number*

Unconditionally assigns the stand-alone drive that *device_number* specifies. The drive must contain media and be ready. By using this option, manual operator assignment is not required. The number for the drive can be obtained from the Media Manager configuration.

`-n drive_name`

Unconditionally assigns the stand-alone drive that *drive_name* specifies. The drive must contain media and be ready. By using this option, manual operator assignment is not required. The name for the drive can be obtained from the Media Manager configuration.

`-erase [-l]`

This option is used to erase the media. Short erase is the default erase. If `-l` option is specified, the media is long erased. A long erase operation can take a long time depending on the type of drive.

`-host media_server`

The *media_server* variable is the host where the drive is attached. This drive is the drive that is used to mount the media. By default, if this option is not used, the command runs on the local system.

NOTES

`tpconfig -d`, `tpconfig -l`, and `vmoprCmd` may truncate long drive names. Use `tpconfig -dl` to obtain the full drive name.

bplist

NAME

`bplist` - list the backed up and archived files on the NetBackup server

SYNOPSIS

```
install_path\NetBackup\bin\bplist [-A | -B] [-C client] [-S master_server]  
[-k policy] [-t policy_type] [-F] [-R [n]] [-b | -c | -u] [-l] [-r]  
[-flops file_options] [-Listseconds] [-T] [-unix_files] [-nt_files]  
[-s date] [-e date] [-I] [-PI] [-help] [-keyword "keyword_phrase"]  
[filename] [-Listpolicy]
```

DESCRIPTION

The `bplist` command shows a list of previously archived or backed up files according to the options that you specify. You can choose the file or directory and the time period that you want the listing to cover. Directories can be recursively displayed to a specified depth. `bplist` shows only the files that you have read access to. It lists the files only if an administrator account performs the user backup. A non-administrator or backup operator cannot use `bplist`.

You also must own or have read access to all directories in the file paths. You can list the files that were backed up or archived by another client only if you are validated to do so by the NetBackup administrator.

If you create the following directory with public-write access, `bplist` creates an debug log file in this directory that you can use for troubleshooting:

```
install_path\NetBackup\logs\bplist\
```

OPTIONS

`-A | -B`

Specifies whether to produce the listing from archives (`-A`) or backups (`-B`). The default is `-B`.

`-C client`

Specifies a client name to use for finding backups or archives to list. This name must be as it appears in the NetBackup configuration. The default is the current client name.

`-S master_server`

Specifies the name of the NetBackup server. The default is the server designated as current on the Servers tab of the **Specify NetBackup Machines** dialog box. To display this dialog box, start the Backup, Archive,

and Restore user interface on the client. Then click **Specify NetBackup Machines** on the File menu.

-t *policy_type*

Specifies one of the following numbers that corresponds to the policy type. The default is 0 for all clients except Windows, where the default is 13.

0 = Standard

4 = Oracle

6 = Informix-On-BAR

7 = Sybase

8 = MS-SharePoint

10 = NetWare

13 = MS-Windows

14 = OS/2

15 = MS-SQL-Server

16 = MS-Exchange-Server

19 = NDMP

35 = NBU-Catalog

Note that the following policy types apply only to NetBackup Enterprise Server.

11 = DataTools-SQL-BackTrack

17 = SAP

18 = DB2

20 = FlashBackup

21 = Split-Mirror

22 = AFS

25 = Lotus Notes

-k *policy*

Names the policy to search to produce the list. If not specified, all policies are searched.

-F

Specifies that in the list output, symbolic links (applies only to UNIX clients) end with a trailing @ and executable files with a trailing *.

-R [*n*]

Recursively lists the subdirectories that are encountered to a depth of *n*. The default for *n* is 999.

`-b | -c | -u`

Specifies an alternate date and time to be used for printing with the `-l` option:

`-b` displays the backup date and time of each file.

`-c` displays the creation date and time for each file.

`-u` displays the last access date and time of each file.

The default is to display the time of the last modification of each file.

`-l`

Shows the file details.

`-Listseconds`

Specifies that seconds granularity be used for the time stamp when the `-l` option is used.

`-r`

Lists the disk images that were backed up. The default is to list file systems.

`-flops file_options`

Lists Backup Exec files or both Backup Exec and NetBackup files. The default (`-flops` not specified) is to list only NetBackup files.

To list only Backup Exe files specify:

`-flops 524288`

To list Backup Exe and NetBackup files specify:

`-flops 1048576`

`-T`

Lists the directories in true-image backups. The default is to list non-true-image backups.

Note: TIR information does not appear for synthetic full backups, even though TIR information is used for synthetic full backups.

`-unix_files`

Lists the files and directories in UNIX format. For example:

`/C/users/test.`

`-nt_files`

Lists the files and directories in Windows format. For example:

`C:\users\test.`

`-s date`

`-e date`

Specifies the start date and end date range for the listing.

`-s` specifies a start date and time for the listing. The resulting list shows only files in backups or the archives that occurred at or after the specified date and time.

The valid range of dates is from 01/01/1970 00:00:00 to 01/19/2038 03:14:07. The default is the current date minus six months.

`-e` specifies an end date and time for the listing. The resulting list shows only files from the backups or the archives that occurred at or before the specified date and time. Use the same format for start date and time. The default is the current date and time.

`-I`

Specifies a case-insensitive search, which means that capitalization is not considered when it compares names (for example, Cat matches cat).

`-PI`

Specifies a path-independent search, which means that NetBackup searches for a specified file or directory without regard to the path. For example, a file with the name `test` exists in the three following directories. A search for `test` finds all three instances of the file:

```
\tmp\junk\test
\abc\123\xxx\test
\abc\123\xxx\yyy\zzz\test
```

`-help`

Prints a command line usage message.

`-keyword "keyword_phrase"`

Specifies a keyword phrase for NetBackup to use when it searches for backups or archives from which to restore files. The phrase must match the one that was previously associated with the backup or archive by the `-k` option of `bpbackup` or `bparchive`.

You can use this option in place of or in combination with the other restore options to make it easier to restore backups and archives. Use the following meta characters to help match keywords or parts of keywords in the phrase:

* matches any string of characters.

? matches any single character.

[] matches one of the sequence of characters that is specified within the brackets.

[-] matches one of the range of characters, separated by the "-".

The keyword phrase can be up to 128 characters in length. All printable characters are permitted including space (" ") and period (".").

The phrase must be enclosed in double quotes ("...") or single quotes ('...').

The default keyword phrase is the null (empty) string.

Note: The keyword phrase is ignored when you use the following policy types: DB2, Informix-On-BAR, Oracle, SAP, MS-SQL-Server, Sybase.

filename

Names the file or directory to list. If you do not specify a path, the default is the current working directory.

Any files or directories that you specify must be listed at the end, following all other options.

Use upper case for the drive letter. For example, C:\NetBackup\log1.

For directories, if you do not use the -R option, include the trailing path separator as in the following:

```
bplist -l "D:\WS_FTP.LOG\*"
```

Note: If you use the asterisk meta character "*", you should use quotation marks around the filename for the command to work properly.

-Listpolicy

Includes the schedule type and policy name in the command output.

EXAMPLES

Example 1 - List recursively in long format

To list recursively in long format, the files that were backed up in

```
D:\WS_FTP.LOG
bplist -l -R D:\WS_FTP.LOG
-rwx----- bjm      bjm                64 Oct 10  1997 D:\WS_FTP.LOG
-rwx----- bjm      bjm                64 Oct 10  1997 D:\WS_FTP.LOG
-rwx----- bjm      bjm                64 Oct 10  1997 D:\WS_FTP.LOG
```

Example 2 - To list with details

Enter the following command to list the files that were backed up and associated with all or part of the keyword phrase "My Home Directory"

```
bplist -keyword "*My Home Directory*" -l C:\home\kwc\
```

Example 3 - To list with details

Enter the following command to list the files that were archived and associated with all or part of the keyword phrase "My Home Directory"

```
bplist -A -keyword "*My Home Directory*" -l C:\home\kwc\
```

Example 4 - To list recursively and with details

Enter the following command to list the files that were backed up on drive D of Windows client slater and associated with all or part of the keyword phrase "Win NT"

```
bplist -keyword "*Win NT*" -C slater -t 13 -R -l D:\
```

FILES

install_path\NetBackup\logs\bplist*.log

SEE ALSO

bp, bparhivc, bpbackup, bprestore

bpmedia

NAME

bpmedia - freeze, unfreeze, suspend, or unsuspend NetBackup media

SYNOPSIS

```
install_path\NetBackup\bin\admincmd\bpmedia -freeze | -unfreeze |  
-suspend | -unsuspend -m media_id [-h host] [-v]  
  
install_path\NetBackup\bin\admincmd\bpmedia -movedb -m media_id  
-newsrvr hostname [-newsrvr_group groupname] [-oldserver hostname]  
[-v]
```

DESCRIPTION

bpmedia allows an individual NetBackup media ID to be controlled in the following terms: whether it allows or disallows future backups or archives to be directed to the media. Note that this command applies only to media that Media Manager manages.

Note: Under certain media or hardware error conditions, NetBackup automatically suspends or freezes media. If action occurs, the reason is logged in the NetBackup Problems report. If necessary, you can use the bpmedia -unfreeze or -unsuspend options to reverse this action.

Any authorized user can run this command.

For more information about NetBackup authorization, refer to the *NetBackup Security and Encryption Guide*.

OPTIONS

-freeze

Freezes the specified media ID. When an active NetBackup media ID is frozen, NetBackup does not direct backups and archives to the media. All unexpired images on the media continue to be available for restores. NetBackup never deletes a frozen media ID from the NetBackup media catalog, nor is it unassigned in the NetBackup volume pool when it expires.

-unfreeze

Unfreeze the specified media ID. This option reverses the action of freeze and allows the media to be used for backups or archives again if it has not

expired. If a media is expired when it is unfrozen, it is immediately unassigned in the NetBackup volume pool.

`-suspend`

Suspend the specified media ID. The action is the same as `freeze` except when the media ID expires, it is immediately unassigned in the NetBackup volume pool.

`-unsuspend`

Unsuspend the specified media ID. This option reverses the action of `suspend` and allows the media to be used for backups or archives again.

`-movedb -newserver hostname [-newsrv_group groupname] [-oldserver hostname]`

Note: You cannot use the `-movedb` option with NetBackup Server.

Moves a media catalog entry from one server to another in a master and a media server cluster. This command moves the media catalog entry for the specified media ID from `oldserver` to `newserver`. It updates the NetBackup image catalog to reflect that the media ID was moved. You can assume that after the move, `newserver` has access to the media.

`-newserver hostname` specifies the name of the host to which the entry is moved.

`-newsrv_group groupname` specifies the name of the new server group that is to own the media.

`-oldserver hostname` specifies the name of the host where the catalog entry to be moved currently resides. If you do not specify `-oldserver`, the system where the command runs is considered to be the old server.

The `-movedb` option is most meaningful in the following configurations: a master and its media servers share a robotic library and have access to all the media in the robot. At a minimum, all NetBackup servers must use the same Enterprise Media Manager Database. With the same database, the media can move from one robotic library to another without losing their attributes and assignment status.

`-m media_id`

Specifies the media ID that requires action. The media ID must be six or fewer characters and must be in the NetBackup media catalog.

`-h host`

Specifies the host name of the server where the media catalog resides. This option is required only if the volume was not written on the server where you run the `bpmedia` command. In this case, the media ID is in the NetBackup media catalog on the other server. You must specify the name of that server on the `bpmedia` command.

For example, assume you have a master server named whale and a media server named eel. You run the following `bpmedia` command on whale in order to suspend media ID BU0001 that is in the media catalog on eel:

```
bpmedia -suspend -m BU0001 -h eel
```

Use the NetBackup Media List report to determine the host that has the volume in its media catalog.

-v

Select verbose mode. This option is only meaningful when NetBackup runs with debug log function on (that is, when the following directory exists:

```
install_path\NetBackup\logs\admin
```

EXAMPLES

Note: You cannot use the `-movedb` option with NetBackup Server.

Assume that the master server is HOSTM, with HOSTS1 and HOSTS2 being media servers. The following command is run on master server HOSTM. It moves the media catalog entry for media ID DLT001 from HOSTS1 to HOSTS2 and updates the NetBackup image catalog:

```
bpmedia -movedb -m DLT001 -newserver HOSTS2 -oldserver HOSTS1
```

FILES

```
install_path\NetBackup\logs\admin\*.log
```

```
install_path\NetBackup\db\media\*.log
```

bpmedialist

NAME

bpmedialist - display NetBackup tape media status

SYNOPSIS

```
install_path\NetBackup\bin\admincmd\bpmedialist [-m list] [-U | -l | -L]
  [-m media_id] [-rl ret_level] [-d density] [-p pool_name] [-h
  host_name | -M master_server,...] [-owner host_name | group_name] [-v]

install_path\NetBackup\bin\admincmd\bpmedialist -summary [-U | -L]
  [-brief] [-p pool_name] [-h host_name | -M master_server,...] [-owner
  host_name | group_name] [-v]

install_path\NetBackup\bin\admincmd\bpmedialist -m contents -m media_id
  [-U | -l | -L] [-d density] [-h host_name | -M master_server,...]
  [-owner host_name | group_name] [-v]

install_path\NetBackup\bin\admincmd\bpmedialist -count -rt robot_type -rn
  robot_number [-d density] [-U | -l] [-h host_name | -M master_server]
  [-v]
```

DESCRIPTION

bpmedialist queries one or more NetBackup media catalogs and produces a report on the status of the NetBackup media. Authorized users can run this command.

For more information about NetBackup authorization, refer to the *NetBackup Security and Encryption Guide*.

bpmedialist produces one of four reports: Media List Report, Media Summary Report, Media Contents Report, Media Count Report.

Media List Report

Media List (-m list) report, provides information on either a single volume or all volumes in the NetBackup media catalog. This report does not apply to disk storage units. The report lists, for each volume in the report, the volume's media ID, media server, and other attributes, which is the default report type.

If -U is an option, the status field appears as English text. Otherwise, the status appears as a hexadecimal integer, a three-digit value. The interpretation of the two upper-order digits is given here. Any or all of these flags can be set. Settings other than those listed here correspond to unreported states.

>= 0x200 Multiplexing is TRUE.

>= 0x080 Imported is TRUE.

>= 0x040 Multiple retention levels is TRUE.

To determine the interpretation for the low-order status digit, compare the digit to the following values in order.

>= 0x008 The status is Full.

>= 0x004 This is an unreported state.

>= 0x002 The status is Suspended.

== 0x001 The status is Frozen.

== 0x000 The status is Active.

The reported status is the status for the low-order digit that is combined with the status for the upper-order digits. For instance, for a status value of 0x040, the media ID is active, and multiple retention levels are in effect.

The -l option produces a report in Short mode. Each media ID occupies one line of the report. The fields on this line are listed later in this description.

For more detail, see the Media List Report section in the *NetBackup Administrator's Guide*. Any of the following fields that are not documented in that section are reserved for NetBackup internal use.

- media id
- partner id
- version
- density
- time allocated
- time last written
- time of expiration
- time last read
- Kbytes
- nimages
- vimages (unexpired images)
- retention level
- volume pool
- number of restores
- status (described previously)
- hsize
- ssize

- l_offset
- reserved
- psize
- reserved
- 4 reserved fields

Media Summary Report

The Media Summary report lists (by server) summary statistics for active and inactive media, which is grouped according to expiration date. The report shows the expiration date for the media and the number of media at each retention level, and the status of each media ID.

Media Contents Report

The Media Contents report lists the contents of media as read directly from the media. It lists the backup IDs that are on a single media ID. It does not list each individual file. This report does not apply to disk storage units. Note that the storage unit may stay in use for some time after the break if the following occurs: you attempt to abort the command by entering `ctrl-c` and the requested media are not mounted or positioned. Each entry in the report appears as that area of the storage unit is read.

The `-l` format for the Media Contents report produces one line for each backup ID and contains the following fields.

For more detail, see the Media Contents Report section in the *NetBackup Administrator's Guide*. Any of the following fields that are not documented in that section are reserved for NetBackup internal use.

- version (1 denotes a DB backup image, 2 denotes a regular backup image)
- backup id
- creation time
- expiration time
- retention level
- fragment number
- file number
- block size (in bytes)
- status
- media_id

- size
- reserved
- data_start
- reserved
- client_type *
- copy_num *
- sched_type *
- flags *
- opt_extra
- mpx_headers
- res1
- policy name *
- schedule label *

* These fields are significant only if version is 2.

Media Count Report

The Media Count report shows a count of the number of UP devices that match all the criteria that is specified. The robot type and the robot number are mandatory criteria for this report. The `-U` format provides a title, Number of UP devices for $rt(rn) = value$. The `-l` format provides only the value.

OPTIONS

Report-type Options

`bpmedialist` produces one of four types of reports. An option on the command line determines the type of report that is produced. The report-type options are as follows:

`-mlist`

Produce a Media List report (the default report type).

`-summary`

Produce a Media Summary report.

`-mcontents`

Produce a Media Contents report.

-count

Produce a Media Count report. This report also displays the following media attribute: `ALLOW_MULT_RET_PER_MEDIA` and its value, 0 (do not allow) or 1 (allow).

Report-format Options

The `bpmédialist` report can appear in one of several formats. The report-format options are as follows:

-brief

Produce a brief report. This option is available for the Media Summary report only. The default is a full report, which includes a breakdown of active and non-active media that report on each media ID's status within these categories.

-U

Report in user mode (the default report mode). The report includes a banner that lists the column titles. The report style is descriptive, rather than terse.

-L

Report in long mode. This format produces the report with the most complete information. For instance, for the Media List report, the report lists each media ID attribute as a series of *keyword = value* pairs, one attribute per line. A value can be expressed as both a numeric value and a descriptive value.

-l

Report in short mode. This format produces a terse report. This option is useful for scripts or the programs that rework the listing contents into a customized report format.

Other options

The following are the remaining options used by `bpmédialist`:

-d *density*

Report on media of this density type. If the robot type is specified on the command line, the value for density should be consistent with the robot type. Available density types are:

4mm - 4mm Cartridge

8mm - 8mm Cartridge

dlt - DLT Cartridge

qscsi - 1/4 Inch Cartridge

Note: The following densities are supported only on NetBackup Enterprise Servers.

dlt2 - DLT Cartridge 2
 dlt3 - DLT Cartridge 3
 dtf - DTF Cartridge
 hcart - 1/2 Inch Cartridge
 hcart2 - 1/2 Inch Cartridge 2
 hcart3 - 1/2 Inch Cartridge 3
 odiskwm - Optical Disk Write-Many
 odiskwo - Optical Disk Write-Once

-m *media_id*

Report on this media ID only. This option is required for the Media Contents report.

For the Media List report, this option is optional. The default condition is that all media IDs are included in that report. The media ID can be provided in either uppercase or lowercase. The media ID must be six or fewer characters and must be in the NetBackup media catalog (that is, assigned from the NetBackup volume pool).

-owner *host_name* | *group_name*

Specifies the owner of the media list. The owner can be a host or a server group.

Note: NetBackup Server has only one server (the master), so use the name of that server for *host_name*.

host_name is either the name of a host, or the character string ALL. If *host_name* is the name of a host, the query goes to the media catalog that resides on the system *host_name*. For the -mcontents and -count options, this option can appear once. For the -mlist and -summary options, this option can appear more than once. The default is all servers in the set of storage units for removable media.

The system *host_name* must allow access by the system running bpmédialist. *host_name* can be a media server for a master server other than the local master server. The default is the master server of the local cluster.

For a media server for a master server other than the local master, if a bpmédialist query is made by using -h *the_media_server*. An equivalent bpmédialist query uses -M *the_media_servers_master*, the bpmédialist using -h may complete faster. This difference in response time can be significant in the following situation: the master server that -M addresses is located remotely and the media server that -h addresses is local.

If *host_name* is ALL, the query goes to the local master server and its media servers.

group_name specifies the name of a server group or the character string ALL. If *group_name* is the name of a server group, the query returns media that the server group owns. If *group_name* is ALL, the query returns media that all the server groups own.

-help

Prints a command line usage message when -help is the only option on the command line.

-M *master_server,...*

A list of alternative master servers. This list is a comma-delimited list of host names. If this option is present, each master server in the list runs the bpmédialist command. If an error occurs for any master server, the report process stops at that point.

The report is the composite of the information that all the master servers in this list return. bpmédialist queries each of these master servers. Each master server in the list must allow access by the system that issues the bpmédialist command.

For -mcontents (Media Contents report) only, the master server returns media information from the media catalogs. This media information is for both the master and its media servers (except for NetBackup Server, which does not support remote media servers). For example, if a media ID exists on a media server of one of the master servers in the -M list, the following occurs: the master retrieves the media information from the media server and returns it to the system running bpmédialist. In this case, both the master server and the media server must allow access by the system that issues the bpmédialist command.

The default is the master server for the server running bpmédialist.

Note: NetBackup Server supports only one server, the master; so the default in this case is always the NetBackup Server master where you run bpmédialist.

-p *pool_name*

Report on the media IDs that belong to this volume pool. The default is all pools.

-rl *retention_level*

Report on the media that use this retention level. The retention level determines how long to retain backups and archives. The *retention_level* is an integer between 0 and 24. The default retention level is 1.

Following are the retention levels with the installation values for the corresponding retention periods. Note that your site may have reconfigured the retention periods that correspond to the retention levels.

- 0 1 week
- 1 2 weeks
- 2 3 weeks
- 3 1 month
- 4 2 months
- 5 3 months
- 6 6 months
- 7 9 months
- 8 1 year
- 9 - 24 infinite

`-rn robot_number`

Report on the robot by using this robot number. This option is required when the `-count` option is used. The robot number can be obtained from the Media Manager device configuration.

For rules about the use of this number, see the *NetBackup Administrator's Guide*.

`-rt robot_type`

Report on a robot of this type. This option is required when the `-count` option is used. For non-robotic (stand-alone) devices select NONE. Valid robot types include the following

TL4 - Tape Library 4MM

TL8 - Tape Library 8MM

TLD - Tape Library DLT

NONE - Not robotic

Note that the following robot types apply only to NetBackup Enterprise Server:

ACS - Automated Cartridge System

ODL - Optical Disk Library

TLH - Tape Library Half-Inch

TLM - Tape Library Multimedia

TSH - Tape Stacker Half-Inch

`-v`

Select verbose mode. This option causes `bpmédialist` to log additional information for debugging purposes. The information goes into the

NetBackup administration daily debug log. This option is meaningful only when NetBackup has the debug logging enabled; that is, when the following directory is defined:

install_path\NetBackup\logs\admin

EXAMPLES

Example 1

The following example produces a media report for all media IDs that are defined for the master server of the local system and any media servers.

Note: For NetBackup Server, the report includes only media IDs for the master server because remote media servers are not supported.

```
bpmedialist
Server Host = hatt
```

id	rl	images vimages	allocated expiration	last updated last read	density	kbytes	restores	STATUS
143191	0	28 7	12/03/2002 23:02 12/29/2002 23:00	12/22/2002 23:00 12/09/2002 10:59	dlt	736288	1	
144280	0	9 0	11/25/2002 11:06 12/08/2002 23:03	12/01/2002 23:03 N/A	dlt	290304	0	EXPIRED FROZEN
AEK800	0	22 7	12/06/2002 03:05 12/30/2002 03:01	12/23/2002 03:01 12/09/2002 10:48	dlt	23213184	0	
C0015	0	28 7	11/26/2002 02:09 12/30/2002 02:01	12/23/2002 02:01 N/A	dlt	896448	0	
IBM001	0	16 14	12/16/2002 01:01 12/30/2002 01:07	12/23/2002 01:07 N/A	dlt	6447360	0	
L00103	0	20 9	12/07/2002 08:33 12/30/2002 01:07	12/23/2002 01:07 N/A	dlt	7657728	0	
L00104	0	9 5	12/11/2002 01:09 12/28/2002 01:04	12/21/2002 01:04 N/A	dlt	5429504	0	

Example 2

The following example produces a media count report for robot type TLD and robot number 0:

```
bpmedialist -count -rt TLD -rn 0
ALLOW_MULT_RET_PER_MEDIA 0
Number of UP devices for TLD(0) = 2
```

Example 3

The following example produces a media contents report for media ID AEK802. The report is partially listed as follows.

```
bpmédialist -mcontents -m AEK802
media id = AEK802, allocated 01/08/2006 03:10, retention level = 0
```

```
File number 1
Backup id = hat_0915786605
Creation date = 01/08/2004 03:10
Expiration date = 01/15/2004 03:10
Retention level = 0
Copy number = 1
Fragment number = 2
Block size (in bytes) = 65536
```

```
File number 2
Backup id = hat_0915809009
Creation date = 01/08/2004 09:23
Expiration date = 01/15/2004 09:23
Retention level = 0
Copy number = 1
Fragment number = 1
Block size (in bytes) = 65536
```

Example 4

In this example, bpmédialist runs on the master server buff. bpmédialist produces a Media List report for master servers hatt and duo.

```
bpmédialist -M hatt,duo
```

```
Server Host = hatt
```

id	rl	images vimages	allocated expiration	last updated last read	density	kbytes STATUS	restores
143191	0	51 9	12/03/2002 23:02 01/18/2003 23:04	01/11/2003 23:04 01/08/2003 10:26	dlt	1436686	2
144280	0	9 0	11/25/2002 11:06 12/08/2002 23:03	12/01/2002 23:03 01/12/2003 16:10	dlt EXPIRED	290304 FROZEN	0
AEK800	0	38 3	12/06/2002 03:05 01/15/2003 03:10	01/08/2003 03:10 12/09/2002 10:48	dlt FULL	3922200024	0
AEK802	0	6 6	01/08/2003 03:10 01/19/2003 03:05	01/12/2003 03:05 01/12/2003 16:12	dlt	6140544	0
C0015	0	48 7	11/26/2002 02:09 01/19/2003 02:11	01/12/2003 02:11 N/A	dlt	1531968	0
IBM000	0	19 13	01/01/2003 01:09 01/19/2003 02:05	01/12/2003 02:05 01/09/2003 05:41	dlt	8284224	0

Server Host = duo

id	rl	images vimages	allocated expiration	last updated last read	density	kbytes	restores
							<----- STATUS ----->
A00004	0	0 0	11/16/2003 05:31 N/A	N/A N/A	4mm FROZEN	0	0
DLT210	1	5 2	12/09/2002 06:10 01/22/2003 06:04	01/08/2003 06:04 N/A	dlt	2560	0
DLT215	0	124 28	12/08/2002 14:57 01/19/2003 08:07	01/12/2003 08:07 12/31/2002 15:42	dlt	9788072	4

Example 5

In this example, `bpmedialist` reports on which of two hosts has a given media ID configured. The host `hatt` does not have `A00004` configured in its media catalog. Therefore, it reports that the requested media ID was not found in the NetBackup media catalog or Enterprise Media Manager Database.

The host `duo` does have `A00004` configured, so it produces a Media List report for `A00004` (the command is all on one line).

```
bpmedialist -mlist -h hatt -h duo -m A00004
```

```
requested media id was not found in NB media database and/or
MM volume database
```

Server Host = duo

id	rl	images vimages	allocated expiration	last updated last read	density	kbytes	restores
							<----- STATUS ----->
A00004	0	0 0	11/16/2003 05:31 N/A	N/A N/A	4mm FROZEN	0	0

FILES

```
install_path\NetBackup\logs\admin\*
EMM database
```

bpminlicense

NAME

bpminlicense - manage NetBackup license file

SYNOPSIS

```
install_path\NetBackup\bin\admincmd\bpminlicense [-path license_key_file  
| -M server] [-debug] [-verbose] [-list_keys] [-nb_features |  
-sm_features]  
  
install_path\NetBackup\bin\admincmd\bpminlicense [-path license_key_file  
| -M server] [-debug] [-verbose] -find_keys | -delete_keys | -add_keys  
keystring1 .. keystringn  
  
install_path\NetBackup\bin\admincmd\bpminlicense -nb_ufile fid [-debug]  
[-verbose]
```

DESCRIPTION

The `bpminlicense` utility manages a NetBackup license file. The preferred method to manage NetBackup licenses is to use the **Help > License Keys** panel in the NetBackup Administration console. For UNIX servers, you may use the `get_license_key(1M)` utility to manage the NetBackup licenses, which is preferred to this command.

Any authorized user can run this command.

For more information about NetBackup authorization, refer to the *NetBackup Security and Encryption Guide*.

OPTIONS

`-add_keys | -delete_keys | -find_keys keystring1 .. keystringn`

Respectively, these options find and list, add, or delete one or more specified *keystrings* in the NetBackup license file.

`-debug`

Display detailed information to standard error.

`-list_keys`

List the keys in the NetBackup license file.

`-M server`

Use the standard NetBackup license file from the specified NetBackup *server*.

`-nb_features`

Lists only active NetBackup feature IDs (and active keys when specified with the `-verbose` option).

`-nb_ufile fid`

Displays licensing information for a specific feature id. For capacity based features, the VALUE field is the total licensed capacity of all active license keys for the feature.

`-sm_features`

Lists only active Storage Migrator feature IDs (and active keys when specified with the `-verbose` option).

`-path license_key_file`

Uses the specified *license_key_file* on the local system. The default is the standard NetBackup license file.

`-verbose`

Displays additional information to standard output. This option is ignored when used with the `-nb_ufile` option.

EXAMPLES

Example 1

In the following example, the administrator wants license information on feature 78, an OpenStorage Disk Option:

```
# bpminlicense -nb_ufile 78
0x05000000;PRID=6 (NetBackup Enterprise Server);FID=78
(OpenStorage Disk Option);SERIAL=0;VALUE=10;
DEXPIRE=2007/07/31 01:00:00 0 (Not expired);
UXDEXPIRE=1185861600 0 (Not expired);
UKEY=OENP-24NJ-PTJT-PPPP-PC6N-PPPP-PNPP-PPPP-POC6
```

Example 2:

In the following example, the administrator wants to know if an active PureDisk license is installed:

```
# ./bpminlicense -verbose
OENC-CPP9-3ZUP-DO83-6PWB-8K40-SKS7-774C-PPP6
OHNW-PPX2-PCDV-UPGP-PZUZ-NCZP-RXXO-GO49-G777-GOP
file version      = 0x05000000
time added       = 0x46388201 Wed May 02 07:20:17 2007
hostname         = hagar
product ID       = 6 NetBackup Enterprise Server
serial number    = 0
```

```
key version      = 0x05000000
count            = 0
server platform  = 0 Any platform
client platform  = 0 Any platform
server tier       = 10 NetBackup Enterprise Server
client tier       = 0 No tier
license type     = 4 Not for resale
OEM ID           = 16 Unknown OEM: 16
Expiration       = Not expired Tue Jul 31 01:00:00 2007
Time Left        = 84 Days
Firm Expiration  = Not expired Tue Jul 31 01:00:00 2007
Feature ID       = 87 PureDisk Storage Upgrade +
Feature ID       = 86 PureDisk Remote Office +
Feature ID       = 85 PureDisk Option +
Feature ID       = 84 SAN Client +
Feature ID       = 83 PureDisk MS Exchange Agent +
```

bpbnt

NAME

bpbnt - perform Authentication tasks from within NetBackup

SYNOPSIS

```
install_path\NetBackup\bin\bpbnt [-AddDomain | -RemoveDomain]
    Private_Domain
install_path\NetBackup\bin\bpbnt [-AddMachine]
install_path\NetBackup\bin\bpbnt [-AddUser | -RemoveUser] Name
    Private_Domain
install_path\NetBackup\bin\bpbnt -Execute [-cf credential_file] command
install_path\NetBackup\bin\bpbnt -GetBrokerCert Broker_Name Broker_Port
install_path\NetBackup\bin\bpbnt -Login -Info credential_file [-cf
    credential_file]
install_path\NetBackup\bin\bpbnt -LoginMachine
install_path\NetBackup\bin\bpbnt -Logout [-cf credential_file]
install_path\NetBackup\bin\bpbnt -RemoveBrokerCert server.name.com
install_path\NetBackup\bin\bpbnt -ShowBrokerCerts
install_path\NetBackup\bin\bpbnt -ShowMachines
install_path\NetBackup\bin\bpbnt -Version
install_path\NetBackup\bin\bpbnt -WhoAmI [-cf credential_file] [-Verify]
```

DESCRIPTION

The bpbnt command is a tool that enables a user to use the Symantec Product Authentication and Authorization Service, which has two distinct pieces.

- Authentication - prove who you are
- Authorization - check what you can do

bpbnt enables a user to do authentication tasks from within NetBackup.

Note: If a command requires a password, it doesn't echo the password or asterisks, which a *shoulder surfer* can use to narrow the password search space significantly.

NetBackup Access Control requires the user's home directories to work correctly.

OPTIONS

`[-AddDomain | -RemoveDomain] Private_Domain`

These options enable an administrator, that runs locally on an Authentication server, to add or remove domains within the private Veritas Domain Database. These domains are not accessible from within any operating system. They are meaningful only within Symantec Product Authentication and Authorization Service. They are intended to be used in places where a centralized naming authority (such as a PDC/AD, or NIS domain) is not available.

You must have administrator privileges to run this command.

`-AddMachine`

Run this option on your authentication broker (root +ab). This option registers a machine in a private Symantec Product Authentication and Authorization Service database. The identity is placed in the private domain `NBU_Machines@<at.server.name>`.

You must have administrator privileges to run this command.

`[-AddUser | -RemoveUser] Private_Domain`

These options enable an administrator, that runs locally on an Authentication server, to add or remove users from domains in the private Veritas Domain Database. These accounts only are meaningful within Symantec Product Authentication and Authorization Service. They are intended to be used in places where a centralized naming authority (such as, PDC/AD or NIS domain) is not available.

You must have administrator privileges to run this command.

`-Execute [-cf credential_file] command`

`-GetBrokerCert`

Obtains a broker certificate without authenticating to a broker.

`-Login -Info credential_file [-cf credential_file]`

Identifies yourself to the system. When you run this command, enter a Name, Password, Domain, Authentication type, and a server to authenticate. The combination of a name, password, domain, and domain type creates a unique identity within an Enterprise-wide network. The first time a broker is contacted, you are asked if you want to trust that broker and authenticate them. You cannot use an untrusted broker.

-LoginMachine

Identifies a machine that uses an account within the Veritas Security Subsystem private domain `NBU_Machines@<at.server.name>`. Run this option on your NetBackup Media, Master, and Clients. This option is similar to when you log in as a user to an authentication broker.

You must have administrator privileges to run this command.

-Logout [-cf *credential_file*]

Invalidates the current user credentials that require the user to log in again to continue. Without the `-cf` option, the credential that is stored at the default location is expired. The `-cf` option points to the actual credential file, which allows a user to explicitly specify the credential to be expired.

-RemoveBrokerCert *server.name.com*

Removes a trust of a specified authentication broker. You can use this command to remove a broker when you no longer trust it. For example, an authentication broker is moved to a different corporate division.

-ShowBrokerCerts

Lists all of the brokers that the user currently trusts. NetBackup trusts any broker that is listed to handle the authentication requests that are sent to it.

-ShowMachines

Lists all machines that have been added to the machines domain of a private Veritas Security Subsystem database by using the `-AddMachines` option. It also shows if DNS fully resolved the machine name. Run this option on your authentication broker (root +ab).

You must have administrator privileges to run this command.

-Version

Retrieves the version of the executable.

-WhoAmI [-cf *credential_file*] [-Verify]

Specifies the identity you currently use within Symantec Product Authentication and Authorization Service. It lists the following:

- Your name
- Domain
- The authenticating broker who issued the credential
- The time a certificate expires
- The domain type that was used when the credential was created

EXAMPLES

Example 1

In the following example, the user uses `-Login` and the default port number to connect to the Authentication Broker that is called `test.domain.veritas.com`. (Authentication Broker is the server that handles the Authentication process.) In the following example, an NIS account is used. Therefore, a domain name (associated with the NIS account) is provided in addition to a user and password.

```
# bpbat -Login
Authentication Broker: test.domain.veritas.com
Authentication port[ Enter = default]:
Authentication type (NIS, NISPLUS, WINDOWS, vx, unixpwd):
NIS
Domain: domain.veritas.com
Name: username
Password:
You do not currently trust the server:
test.domain.veritas.com, do you wish to trust it? (y/n): y
Operation completed successfully.
```

Example 2

The `-WhoAmI` command verifies the identity that you currently use within Symantec Product Authentication and Authorization Service. It lists the following:

- Your name
- Domain
- The authenticating broker who issued the credential
- The time your certificate expires
- The domain type that was used when the credential was created.

```
# bpbat -WhoAmI
Name: user name
Domain: domain.veritas.com
Issued by: /CN=broker/OU=root@eek.min.veritas.com/O=vx
Expiry Date: Oct 27 20:57:43 2003 GMT
Authentication method: NIS
Operation completed successfully.
```

Example 3

Adding a machine to the machine identities list:

```
# bpbat -AddMachine
```

```
Machine Name: auto.domain.veritas.com
Password:
Operation completed successfully.
```

Showing the machine identities list:

```
# bpbat -ShowMachines
auto.domain.veritas.com
Operation completed successfully
```

Logging in a machine to a specified authentication broker:

```
# bpbat -LoginMachine
Does this machine use Dynamic Host Configuration Protocol
(DHCP)? (y/n) n
Authentication Broker: test.domain.veritas.com
Authentication port[ Enter = default]:
Name: auto.domain.veritas.com
Password:
Operation completed successfully.
```

You log into a machine to a specified authentication broker and a problem occurs:

If the user has a multi-NIC configuration or types the broker name incorrectly, a second prompt appears. It gives the user a second chance to enter the proper broker name. The following example assumes `sleemanNB` is a private NIC name. The public NIC name that Symantec Product Authentication and Authorization Service uses to build the authentication domain is `sleeman.min.veritas.com`. If a failure occurs using `-loginmachine`, the user has a second chance to enter an explicit primary hostname for the authentication broker. (Failures include a bad machine name, wrong password, or incorrect broker name). Refer to the following example:

```
# bpbat -LoginMachine
Does this machine use Dynamic Host Configuration Protocol
(DHCP)? (y/n) n
Authentication Broker: sleemanNB
Authentication port[ Enter = default]:
Machine Name: challenger
Password:
Primary host name of broker: sleeman.min.veritas.com
Operation completed successfully.
```

Example 4

This command is used to obtain a broker certificate without authenticating to a broker. It expects a broker (test.domain.veritas.com) and a port (0 for default)

```
# bpbat -GetBrokerCert test.domain.veritas.com 0
Operation completed successfully.
```

Example 5

This command lists all the brokers that the user currently trusts

```
# bpbat -ShowBrokerCerts
Name: root
Domain: root@test.domain.veritas.com
Issued by: /CN=root/OU=root@test.domain.veritas.com/O=vx
Expiry Date: Jun 12 20:45:19 2006 GMT
Authentication method: Symantec Private Security

Name: root
Domain: root@auto.domain.veritas.com
Issued by: /CN=root/OU=root@auto.domain.veritas.com/O=vx
Expiry Date: Feb 17 19:05:39 2006 GMT
Authentication method: Symantec Private Security

Name: root
Domain: root@torpedo.domain.veritas.com
Issued by: /CN=root/OU=root@torpedo.domain.veritas.com/O=vx
Expiry Date: May 13 23:20:58 2006 GMT
Authentication method: Symantec Private Security
Operation completed successfully.
```

Example 6

The `-RemoveBrokerCert` option removes a broker when the user no longer wants to trust it. In the following example, an authentication broker is moved to a different corporate division.

```
# bpbat -RemoveBrokerCert test.domain.veritas.com
Operation completed successfully.
```

The user can now use the `-ShowBrokerCerts` option to display current certificates. The previously removed certificate is no longer displayed.

SEE ALSO

`bpbab`

bpbaz

NAME

bpbaz - perform Authorization administration tasks from within NetBackup

SYNOPSIS

```

install_path\NetBackup\bin\admincmd\bpbaz -[AddUser | DelUser]
    Group_Name Domain_Type:Domain_Name:User_Name [-OSGroup] [-M server]
    [-Server server1.domain.com] [-CredFile Credential]

install_path\NetBackup\bin\admincmd\bpbaz -[AddGroup | DelGroup]
    Group_Name [-M server] [-Server server1.domain.com] [-CredFile
    Credential]

install_path\NetBackup\bin\admincmd\bpbaz -UpGrade60

install_path\NetBackup\bin\admincmd\bpbaz -[ListPerms | ListMainObjects
    | ListGroups | ShowAuthorizers] [-M server] [-Server
    server1.domain.com] [-CredFile Credential]

install_path\NetBackup\bin\admincmd\bpbaz -ListGroupMembers Group_Name
    [-M server] [-Server server1.domain.com] [-CredFile Credential]

install_path\NetBackup\bin\admincmd\bpbaz -AddPerms
    Permission_1[,Permission_2,...] -Group Group_Name -Object Object [-M
    server] [-Server server1.domain.com] [-CredFileCredential]

install_path\NetBackup\bin\admincmd\bpbaz -DelPerms [Permission_1,...]
    -Group Group_Name -Object Object [-M server] [-Server
    server1.domain.com] [-CredFileCredential]

install_path\NetBackup\bin\admincmd\bpbaz
    -[AllowAuthorization|DisallowAuthorization] Machine Name [-M server]
    [-Server server1.domain.com]

install_path\NetBackup\bin\admincmd\bpbaz -SetupSecurity
    NBU.Master.Server.com [-M server] [-Server server1.domain.com]

```

DESCRIPTION

NetBackup uses the `bpbaz` command to access the authorization portion of Symantec Product Authentication and Authorization Service. Authorization checks the rights on an object. This command enables you to do the following:

- Add users to Az groups
- Create Az groups
- Add and remove permissions from the main NetBackup resource objects

- Add and remove permissions on individual policies
- List current permissions on NetBackup resource and policies
- List Az groups
- Lists the users within Az groups
- Permit machines to perform authorization actions
- Setup the initial security information

To use this command and its associated options, you must be a member of the NetBackup Security Administrators group (NBU_Security Administration). The only exception is with the SetupSecurity command.

You must have local administrator privileges on the authorization server to to run this command.

When you use `bpbaz`, assume that the Master server and the Az server are the same machine.

Note: The use of NetBackup Access Control requires the user's home directories to work correctly.

OPTIONS

`-AddGroup Group_Name`

Creates an authorization group that is defined with the variable `Group_Name`.

Note: An Az group is a collection within the Authorization engine into which OS groups and OS users can be placed. When you add a user to an Az group, you grant them the rights and privileges that are associated with that group.

`-AddPerms Permission_1[,Permission_2,...]`

Adds the permissions that are specified for the given role to the object or policy in question. Refer to the *NetBackup Administrator's Guide* for additional information.

`-AddUser Group_Name Domain_Type:Domain_Name:User_Name`

Adds users by creating a unique enterprise account name, following this format: <Authentication type>:<Domain_Type>:<User_Name>

The supported Authentication types for this variable are:

Nis ... Network Information Services

NISPLUS ... Network Information Services Plus

Unixpwd ... UNIX Password file on the Authentication server
WINDOWS ... Primary Domain Controller or Active Directory
Vx ... Veritas Private database.

The *Domain_Type* variable is the domain that the user or group belongs, and the *User_Name* variable defines the applicable user or group name.

-AllowAuthorization *Machine Name*

Specifies which machines are allowed to perform authorization checks. The security administrator must specify which servers (Master or Media) are permitted to examine the Authorization database to perform authorization checks.

-CredFile *Credential*

Specifies a file name (*Credential*) from which to obtain a Symantec Product Authentication and Authorization Service credential, rather than the default location.

-DelGroup *Group_Name*

Deletes all the members of the group when you delete an Az group from the authorization engine. This operation is not reversible; if you remove a group, you revoke the rights that are granted to members of the group.

-DelPerms

Deletes all permissions from an object for a given group.

-DelUser *Group_Name* Domain Type:Domain_Name:User_Name

Removes a user from an authorization group. This operation is not reversible. Refer to the AddUser option for definitions of the *Domain_Type*, *User_Names*, and *Authentication* types.

-DisallowAuthorization *Machine Name*

Specifies which machines are not allowed to perform authorization checks. The security administrator must specify which servers (Master or Media) are not permitted to examine the Authorization database to perform authorization checks.

-Group *Group_Name*

Identifies the authorization group on which an operation is to be performed. NetBackup does not allow user groups to be nested.

-ListGroupMembers *Group_Name*

Lists the group member that are associated with a particular group defined by *Group_Name*.

-ListGroup

Lists the defined groups.

-ListMainObjects

Lists the current permissions for each group on each of the main NetBackup objects. This list is an informative view that you can use to verify changes to permissions on an object. This option shows the permissions each group has within the authorization system.

-ListPerms

Shows all applicable permissions for a given object or object type within the database. This option helps the user to create meaningful customizations to their authorization.

-M *server*

Specifies the name of the master server as defined in the variable *server*. This server name may be different from the local host name.

-Object *Object*

Controls the access to specified objects or object collections.

-OSGroup

Defines a named collection of authentication principals that are established in a native operating system and treated as a single entity. All members of an authentication group or OS group are from the same authentication domain.

-SetupSecurity

This option must be run as root on the Az server.

-Server *server1.domain.com*

This option specifies the Az server being used. Currently we expect the Az server and the NetBackup master server to exist on the same system.

-ShowAuthorizers

This option lists the machines are allowed to perform authorization checks.

-Upgrade60

This option modifies the NBU_Operator groups permissions to enable an operator to view general media and device information continually. This command should only be run when you upgrade a system from NetBackup 5.x (any release level) to NetBackup 6.x.

Examples

Example 1

An Az group is a collection within the Authorization engine where other OS groups and OS users are placed. This collection is the building block against which permissions are applied on the objects within the database. If you add a user to an Az group, you grant them all the rights and privileges that are associated with that group. When a user is placed in more than one group, that

user's effective permissions are as follows: the logical "or" of the applicable permissions of each group to which the user belongs. The following example demonstrates how to create and list an existing Az group.

```
install_path\NetBackup\bin\admincmd\bpbaz -AddGroup "New Group 1"
-server test.domain.veritas.com
Operation completed successfully.
install_path\NetBackup\bin\admincmd\bpbaz -ListGroup -server
test.domain.veritas.com
Administrators
Operators
Security Administrators
Resource Management Applications
Applications
New Group 1
NBU_Unknown
NBU_User
NBU_Operator
NBU_Media Device Operator
NBU_Admin
NBU_Executive
NBU_Security Admin
NBU_Database Agent Operator
NBU_Database Agent Administrator
Operation completed successfully.
```

Example 2

Deleting an Az group:

If you delete an Az group from the authorization engine, all the members are removed from the group. This operation is not reversible. When you remove a group, you revoke the rights that are granted to members of the group.

Therefore, carefully consider the implications of deleting groups.

```
install_path\NetBackup\bin\admincmd\bpbaz -DelGroup "New Group 1"
-server test.domain.veritas.com
Operation completed successfully.
install_path\NetBackup\bin\admincmd\bpbaz -ListGroup -server
test.domain.veritas.com
Administrators
Operators
Security Administrators
Resource Management Applications
Applications
NBU_Unknown
NBU_User
NBU_Operator
NBU_Media Device Operator
NBU_Admin
NBU_Executive
NBU_Security Admin
```

```
NBU_Database Agent Operator
NBU_Database Agent Administrator
Operation completed successfully.
```

Example 3

Adding and removing users from Az groups (and List group members):

Add users by creating a unique enterprise name of the following format:

<Authentication type>:<Domain to which user or group belongs>:<user or group name>

Supported Authentication types are:

- Nis - Network Information Services
- NisPlus - Network Information Services Plus
- Unixpwd - UNIX Password file on the Authentication server
- WINDOWS - Primary Domain Controller or Active Directory
- Vx - Veritas Private database

```
install_path\NetBackup\bin\admincmd\bpbaz -AddUser NBU_Operator
nis:domain.veritas.com:ssosa -server test.domain.veritas.com
Operation completed successfully.
```

```
install_path\NetBackup\bin\admincmd\bpbaz -ListGroupMembers
NBU_Operator -server test.domain.veritas.com
=====
```

```
Type: User
Domain Type: nis
Domain:domain.veritas.com
Name: jdimaggio
=====
```

```
Type: User
Domain Type: nis
Domain:domain.veritas.com
Name: ssosa
```

Operation completed successfully.

```
install_path\NetBackup\bin\admincmd\bpbaz -DelUser NBU_Operator
nis:domain.veritas.com:ssosa -server test.domain.veritas.com
Operation completed successfully.
```

```
install_path\NetBackup\bin\admincmd\bpbaz -ListGroupMembers
NBU_Operator -server test.domain.veritas.com
=====
```

```
Type: User
Domain Type: nis
Domain:domain.veritas.com
Name: jdimaggio
```

Operation completed successfully.

Example 4

Listing Applicable Permissions:

The `-ListPerms` option shows all applicable permissions for a given object or object type within the database. This information helps the user to create meaningful customizations to their authorization.

```
install_path\NetBackup\bin\admincmd\bpbaz -ListPerms -server
test.domain.veritas.com
    Object Type: Unknown
Browse
Object Type: Media
    Browse
    Read
    New
    Delete
    Eject
    . . .
    Restart
    Synchronize
Object Type: PolicyGroup
    Browse
    Read
    New
    Delete
    Activate
    Deactivate
    Backup
Operation completed successfully.
```

Example 5

Listing Main Objects:

The `-ListMainObjects` option lists the current permissions for each group on each of the main NetBackup objects. This list is an informative view that can be used to verify changes to permissions on an object. It shows what permissions each group has within the authorization system.

```
install_path\NetBackup\bin\admincmd\bpbaz -ListMainObjects -server
test.domain.veritas.com
. . .
NBU_RES_Policy:
    Role: NBU_User
        Unknown
    Role: NBU_Media Device Operator
        Browse
        Read
    Role: NBU_Executive
        Read
        Browse
    Role: NBU_Database Agent Operator
        Unknown
    Role: NBU_Unknown
    Unknown
    Role: NBU_Operator
        Browse
```

```

    Read
Role: NBU_Admin
    Browse
    New
    Activate
    Backup
    Read
    Delete
    Deactivate
Role: NBU_Security Admin
    Unknown
Role: NBU_Database Agent Administrator
    Unknown
Role: Administrators
    Unknown
Role: Operators
    Unknown
Role: Applications
    Unknown
Role: NBU_Security Admin
    Unknown
. . .
NBU_RES_Job:
    Role: NBU_Media Device Operator
        Browse
        Suspend
        Cancel
        Read
        Resume
        Delete
    Role: NBU_Executive
        Browse
        Read
    Role: NBU_Database Agent Operator
        Unknown
    Role: NBU_User
        Unknown
    Role: NBU_Unknown
        Unknown
    Role: NBU_Operator
        Browse
        Suspend
        Cancel
        Read
        Resume
        Delete
    Role: NBU_Admin
        Browse
        Delete
        Resume
        Read
        Suspend

```

```

Cancel
Role: NBU_Security Admin
Unknown
Role: NBU_Database Agent Administrator
Unknown
Role: Administrators
Unknown
Role: Operators
Unknown
Role: Applications
Unknown
Role: NBU_Security Admin
Unknown

```

```

. . .
Operation completed successfully.

```

Example 6

Adding and deleting permissions from an object or policy:

Deletion deletes all permissions from an object for a given group. Add adds the permissions that are specified for the given role to the object or policy in question.

```

install_path\NetBackup\bin\admincmd\bpbaz -AddPerms Browse,Read,
New,Delete -Group TestGroup1 -Object NBU_RES_Job -server
test.domain.veritas.com
Operation completed successfully.
install_path\NetBackup\bin\admincmd\bpbaz -ListMainObjects -server
test.domain.veritas.com
NBU_RES_Unknown:
    Role: NBU_User
. . .
NBU_RES_Job:
    Role: NBU_Media Device Operator
        Browse
        Suspend
        Cancel
        Read
        Resume
        Delete
    Role: NBU_Executive
        Browse
        Read
    Role: NBU_Database Agent Operator
        Unknown
    Role: TestGroup1
        Read
        Delete
        New
        Browse
    Role: NBU_User
        Unknown
    Role: NBU_Unknown

```



```

Unknown
Role: NBU_Operator
  Browse
  Suspend
  Cancel
  Read
  Resume
  Delete
Role: NBU_Admin
  Browse
  Delete
  Resume
  Read
  Suspend
  Cancel
Role: NBU_Security Admin
  Unknown
Role: NBU_Database Agent Administrator
  Unknown
Role: Administrators
  Unknown
Role: Operators
  Unknown
Role: Applications
  Unknown
Role: NBU_Security Admin
  Unknown
NBU_RES_Service:
  Role: NBU_Unknown

```

. . .

```

Operation completed successfully.
install_path\NetBackup\bin\admincmd\bpbaz -DelPerms -Group
TestGroup1 -Object NBU_RES_Policy -server test.domain.veritas.com
Operation completed successfully.

```

Example 7

Specifies what servers can perform Authorization checks. Also views what servers can perform Authorization checks. In addition, Disallows a server from performing Authorization checks:

The `-AllowAuthorization` option specifies which machines are allowed to perform authorization checks. The security administrator must specify which servers (Master or Media) are permitted to examine the Authorization database to perform authorization checks. The following examples demonstrate how to allow or disallow a machine to perform authorization.

```

install_path\NetBackup\bin\admincmd\bpbaz AllowAuthorization
butterball.domain.veritas.com -server test.domain.veritas.com
Operation completed successfully.

```

```

install_path\NetBackup\bin\admincmd\bpbaz -ShowAuthorizers -server
test.domain.veritas.com

```

```
=====  
Type: User  
Domain Type: vx  
Domain:NBU_Machines@test.domain.veritas.com  
Name: butterball.domain.veritas.com  
Operation completed successfully.  
install_path\NetBackup\bin\admincmd\bpbaz -DisallowAuthorization  
butterball.domain.veritas.com -server test.domain.veritas.com  
Operation completed successfully.  
install_path\NetBackup\bin\admincmd\bpbaz -ShowAuthorizers -server  
test.domain.veritas.com  
Operation completed successfully.
```

Example 8

Initial security boot strapping:

The user must run the `-SetupSecurity` option as root on the Az server. The user must then provide the login information for the first NetBackup Security administrator.

Note: The root user on the system upon which the Az server is installed is always a security administrator.

```
install_path\NetBackup\bin\admincmd\bpbaz -SetupSecurity  
test.domain.veritas.com -server test.domain.veritas.com  
Authentication Broker: test.domain.veritas.com  
Authentication port[ Enter = default]:  
Domain: domain.veritas.com  
Name: ssosa  
Password: Authentication type (NIS, NISplus, WINDOWS, vx, unixpwd:  
NIS  
Operation completed successfully.
```

SEE ALSO

bpbat

bpficorr

NAME

`bpficorr` - list the persistent snapshot information in the NetBackup catalog for a specified client and delete catalog entries for the snapshots that no longer exist

SYNOPSIS

```
install_path\NetBackup\bin\admincmd\bpficorr [-media] [-hoursago hours]  
[-rotation] [-policy policy_name] -client client_name
```

DESCRIPTION

For the specified client, `bpficorr` lists the persistent snapshots currently found in the NetBackup catalog. Without the `-media` option, `bpficorr` compares the catalog information to the actual information on the client. It removes any entries in the catalog that do not have corresponding snapshots on the client. This option is useful if a snapshot on the client is renamed or removed.

Note: NetBackup manages persistent snapshots. Do not rename or remove a persistent snapshot; otherwise, the data cannot be restored.

The output of `bpficorr` goes to standard output.

You must have superuser privileges to initiate this command.

OPTIONS

`-media`

Lists all persistent snapshot entries in the NetBackup catalog for the client that is specified on the `-client` option. The list includes the backup IDs and the media descriptions for each backup ID. See the *NetBackup Administrator's Guide* for details on the media description.

`-hoursago hours`

Includes the images that were written up to *n* hours ago (1 or greater). The default is all images.

`-policy policy_name`

NetBackup lists the persistent snapshot information in the NetBackup catalog for this policy for the specified client. The default is all policies that include the client that is specified on the `-client` option.

`-client client_name`

A required option. NetBackup lists the persistent snapshot information in the NetBackup catalog for this client. This name must be as it appears in the NetBackup catalog. By default, bpfficorr searches for all clients.

NOTES

bpfficorr writes activity log information to the `/usr/opensv/netbackup/logs/admin` directory. You can use the information in the directory for troubleshooting.

EXAMPLES

Example 1

To resynchronize the NetBackup catalog with a client's actual snapshots:

```
install_path\NetBackup\bin\admincmd\bpfficorr -client lupine
```

Example 2

To display the snapshots that are currently in the catalog for client lupine:

```
install_path\NetBackup\bin\admincmd\bpfficorr -media -client lupine
```

Sample output:

Listing frozen image info from NBU catalog

```
-----  
backup_id          created          name  
-----  
1 lupine_1034167036 Wed Oct  9 07:37:16 2002  
1 vxvm:32:vxfs:/V1fs:/dev/vx/dsk/oradg/PFI-V1_1034167036  
2 lupine_1033995680 Mon Oct  7 08:01:20 2002  
1vxfs_pfi:34:vxfs:/ora8:VX+NBU+PFI+ORA+2002.10.07.08h01m20s  
3 lupine_1033880459 Sun Oct  6 00:00:59 2002  
1 vxfs_pfi:34:vxfs:/V1fs:VX+NBU+PFI+FS+2002.10.06.00h00m59s
```

bplclients

NAME

bplclients - administer clients within NetBackup policies

SYNOPSIS

```
install_path\NetBackup\bin\admincmd\bplclients  
install_path\NetBackup\bin\admincmd\bplclients policy_name | -allunique  
    [-pt policy_type] [-L | -l | -U | -noheader] [-M master_server,...]  
    [-v]  
install_path\NetBackup\bin\admincmd\bplclients policy_name [-M  
    master_server,...] [-v] -add host_name hardware os [-priority  
    priority]  
install_path\NetBackup\bin\admincmd\bplclients policy_name [-M  
    master_server,...] [-v] -delete host_name ...  
install_path\NetBackup\bin\admincmd\bplclients policy_name [-M  
    master_server,...] [-v] -modify host_name [-hardware hardware] [-os  
    os] [-priority priority]  
install_path\NetBackup\bin\admincmd\bplclients policy_name -rename  
    old_client_name new_client_name [-os os] [-hardware hardware]
```

DESCRIPTION

bplclients does one of the following:

- Produce a listing of clients.
- Add a new client to a policy.
- Delete a list of clients from a policy.
- Modify an existing client in a policy.

For the `-add`, `-delete`, and `-modify` options, `bplclients` returns to the system prompt immediately after it submits the client change request to NetBackup. To determine whether the change was successful, run `bplclients` again to list the updated client information.

When the listing option is used, the list is ordered alphabetically by client name. Each client entry is on a single line, with a single entry for each client.

Authorized users can initiate this command.

For more information about NetBackup authorization, refer to the *NetBackup Security and Encryption Guide*.

OPTIONS

`bplclients` consists of two forms. The `bplclients` form that you use determines the options that you use with `bplclients`.

The first form of `bplclients` has no options and produces a listing of information about the clients for all policies.

The second form of `bplclients` produces a listing of information about the clients for a single policy or for all policies. The following options apply to this form:

```
policy_name | -allunique [-pt policy_type]
```

policy_name specifies the name of a policy. It lists client information only for the policy with this name.

`-allunique` without `[-pt policy_type]` lists client information for all policies that are defined for NetBackup on the master server.

If you use `-allunique -pt policy_type`, where *policy_type* is a specific policy type (such as Sybase), the following occurs: the command lists the client information only for the clients that belong to that type of policy.

If the command line contains neither the *policy_name* nor `-allunique` option, the listing contains client information for all policies.

If you use this option, it must be the first option on the command line.

-L

List in long format. No two-line header appears at the top of the listing; the header is embedded in the line for each client. The line for each client includes the following fields:

Client/HW/OS/Pri: (the header)

Client name

Hardware type

Operating system

Priority

Ignore the four additional fields. They are either unused or used for internal processes.

-l

List in short format; this option produces a terse listing. It also is called *raw output mode*. No two-line header appears at the top of the listing; the header is embedded in the line for each client. The line for each client includes the following fields:

CLIENT (the header)

Client name

Hardware type

Operating system

Priority

You can ignore the four additional fields. They are either unused or used for internal processes.

This option is useful for scripts or the programs that rework the listing contents into a customized report format.

-U

Lists in user format. The listing consists of one line for each client, which contains the hardware type, operating system, and client name. A two-line header begins the listing. This option is the default format for the listing.

-noheader

List without any header. The listing consists of one line for each client, which contains the hardware type, operating system, and client name.

-M *master_server, . . .*

Lists alternative master servers. This option consists of a comma-delimited list of host names. If this option is present, each master server in the list runs the `bplclients` command. Each master server in the list must allow access by the system that issues the `bplclients` command. If an error occurs for any master server, the process stops at that point.

If `bplclients` produces a list, the list is the composite of the returned information from all the master servers in this list.

If `bplclients` adds, deletes, or modifies a client (explained later), the change is made on all the master servers in this list.

-v

Selects the verbose mode. This option causes `bplclients` to log additional information for debugging purposes. The information goes into the NetBackup administration daily debug log. This option is meaningful only when you enable the debug log function (that is, when the following directory is defined):

```
install_path\NetBackup\logs\admin
```

Note: The next three forms of the `bplclients` command affect one or more clients in a single policy. The client is added, deleted, or its attributes are modified within the policy. This form of `bplclients` uses the *policy_name* -M *master_server*, and -v options:

policy_name

Change the client information for this policy. This option must be the first option on the command line.

`-M master_server, ...`

Explained earlier. This option must precede the `-add`, `-delete`, or `-modify` option on the command line.

`-v`

Explained earlier. This option must precede the `-add`, `-delete`, or `-modify` option on the command line.

Note: The next three options, `-add`, `-delete`, and `-modify`, determine the change that `bplclients` makes to the clients for the policy. Any of these options, with its accompanying client information, must be the final option on the command line. Only one of these options can be used at a time.

`-add host_name hardware os [priority]`

Add a client to the policy. If the local system has defined the maximum number of clients already, an error is returned. The maximum number of clients is unlimited (the installation default) for NetBackup Enterprise Server and 4 for NetBackup Server. Specify the host name, hardware type, and operating system (see the definitions section). (*priority* is not implemented at this time)

`-delete host_name ...`

Delete one or more clients from the policy. Up to twenty clients can be deleted at a time. The clients are provided as a space-delimited list of host names.

`-modify host_name ...`

Modify the attributes for a client within a policy. The client was added to the policy previously. The attribute values follow the client name and replace the previous equivalent attribute values for this client. You must modify at least one of the client's attributes. `-priority` is not implemented at this time.

`-hardware hardware`

The hardware type of this client. In the dialog box for adding clients to a policy with the Backup Policy Management utility, select one of the hardware types.

`-os os`

The operating system of this client. In the dialog box for adding clients to a policy with the Backup Policy Management utility, select one of the operating systems.

The values that you choose for the hardware and the `os` options must form a valid combination.

`-priority priority`
Not implemented.

Note: The following form of `bplclients` changes the name of the client in a policy. It also can change the operating system and hardware type that is specified for the client. This form of `bplclients` uses the following options:

`policy_name`

The policy that has the client. This option must be the first option on the command line.

`-rename old_client_name new_client_name`

`old_client_name` specifies the current name of the client and
`new_client_name` specifies the new name.

`-hardware hardware`

Specifies a different hardware type for the client. In the dialog box adding clients to a policy with the Backup Policy Management utility, select one of the hardware types .

`-os os`

Specifies a different operating system for the client. In the dialog box for adding clients to a policy with the Backup Policy Management utility, select one of the operating systems.

The values that you choose for the hardware and the `os` options must form a valid combination.

EXAMPLES

Example 1

While the master server runs, list the clients that are known to the master server.

```
bplclients
```

The returned output looks like the following:

Hardware	OS	Client
-----	-----	-----
Novell	Novell 5.1	marge
Windows	Windows	marmot
HP9000-800	HP-UX 11.0	squash
PC	Windows	tigers

This command can also be entered on a client of `hatt`, with the same results.

Example 2

List the defined clients for the policy `onepolicy`:

```
bplclients onepolicy
```

Hardware	OS	Client
-----	-----	-----
Solaris	Solaris8	jeckle
RS6000	AIX5	streaky
HP9000-800	HP-UX 11.0	chilly
ALPHA	OSFI_V5	alpha
Solaris	Solaris8	heckle
HP9000-800	HP-UX	shark

Example 3

Add the client `marmot` to the policy `twopolicy` on the master servers `serv1` and `serv2`. The hardware type for `marmot` is `HP9000`; the operating system is `HP-UX 11.0`. The default priority is used. (The command is all on one line.)

```
bplclients twopolicy -M serv1,serv2 -add marmot HP9000 HP-UX 11.0
```

Example 4

Delete the clients `marmot` and `vole` from the policy `twopolicy` on the master servers `serv1` and `serv2`. (The command is all on one line.)

```
bplclients twopolicy -M serv1,serv2 -delete marmot vole
```

Example 5

While the master server `hatt` runs, list client information for policy `BackTrack` on the master server `beaver`:

```
bplclients BackTrack -M beaver
```

Hardware	OS	Client
-----	-----	-----
Solaris	Solaris8	saturn

Example 6

Assume you have a policy that is called `my_policy` with one defined client. The client name is `pear`, the operating system is `Solaris2.9`, and the hardware type is `Solaris`.

```
bplclients my_policy -rename pear apple -os MacOS \
-hardware MACINTOSH
```

This command changes the client name `pear` in `my_policy` to `apple`. It also changes the `os` from `Solaris` to `MacOS` and hardware from `Solaris` to `Macintosh`.

RETURN VALUES

An exit status of 0 means that the command ran successfully.

Any exit status other than 0 means that an error occurred.

If the administrative log function is enabled, the exit status is logged in the administrative daily log under the log directory:

```
install_path\NetBackup\logs\admin
```

It has the following form:

```
bplclients: EXIT status = exit status
```

If an error occurred, a diagnostic precedes this message.

FILES

install_path\NetBackup\logs\admin*

install_path\NetBackup\db\policy*policy_name*\clients

SEE ALSO

bplinfo

bpldelete

NAME

bpldelete - delete policies from the NetBackup database

SYNOPSIS

```
install_path\NetBackup\bin\admincmd\bpldelete policyname [-verbose] [-M  
master_server, ...master_server]
```

DESCRIPTION

bpldelete deletes policies from the NetBackup database.

Any authorized user can initiate this command.

For more information about NetBackup authorization, refer to the *NetBackup Security and Encryption Guide*.

OPTIONS

-M master_server, ...master_server

Delete policy information for a specific master server(s). For example, to delete policy MWF_PM from master server Saturn, enter:

```
bpldelete MWF_PM -M Saturn
```

-verbose

Select verbose mode for logging.

policyname

Specifies the policy to remove from the NetBackup database.

bpplinclude

NAME

bpplinclude - maintain list of files automatically backed up by NetBackup policy

SYNOPSIS

```
install_path\NetBackup\bin\admincmd\bpplinclude policy_name [-v] [-M  
master_server,...] -L | -l  
install_path\NetBackup\bin\admincmd\bpplinclude policy_name [-v] [-M  
master_server,...] -add pathname ...  
install_path\NetBackup\bin\admincmd\bpplinclude policy_name [-v] [-M  
master_server,...] -add -f filename  
install_path\NetBackup\bin\admincmd\bpplinclude policy_name [-v] [-M  
master_server,...] -delete pathname  
install_path\NetBackup\bin\admincmd\bpplinclude policy_name [-v] [-M  
master_server,...] -delete -f filename  
install_path\NetBackup\bin\admincmd\bpplinclude policy_name [-v] [-M  
master_server,...] -modify old_pathname new_pathname ...
```

DESCRIPTION

bpplinclude maintains the policy file list for a NetBackup policy. The policy file list is the list of files that are backed up when NetBackup runs an automatic backup for the policy. The policy file list does not apply to user backups or archives since users select the files when they start those operations.

bpplinclude performs one of the following operations:

- Adds the pathnames to the policy file list
- Deletes the pathnames from the policy file list
- Modifies the pathnames in the policy file list
- Displays the policy file list for a policy

The `-add`, `-delete`, and `-modify` options include a list of pathnames. The list of pathnames must be the final part of the `bpplinclude` command line. The pathname must be the entire path from the root of the file system to the desired location.

For the absolute pathname syntax for your client type, refer to the File-Path Rules topics in the *NetBackup Administrator's Guide*.

The last part of the path can be a filename, a directory name, or a wildcard specification. You can enclose pathnames in quotes. Use enclosing quotes if the pathname contains special characters or a wildcard specification.

File-Path Rules does not verify the existence of the input directories or files. NetBackup backs up only the files it finds and does not require that all entries in the list be present on every client.

See the *NetBackup Administrator's Guide* for additional information on policy file lists.

For database extensions, the input entries are scripts. NetBackup runs these during the backup. See the NetBackup guide that comes with the extension product for additional information.

The added entries to the policy file list can be directives, rather than pathnames for the following: certain policy attributes (such as Allow Multiple Data Streams) and extension products (such as NetBackup for NDMP).

Refer to the *NetBackup Administrator's Guide* or the NetBackup guide for the extension product.

The options `-l` and `-L` produce nearly identical displays of the policy file list.

`bplinclude` sends its error messages to `stderr`. `bpplinclude` sends a log of its activities to the NetBackup admin log file for the current day.

Authorized users can initiate this command.

For more information about NetBackup authorization, refer to the *NetBackup Security and Encryption Guide*.

OPTIONS

`-add pathname ...`

Adds the specified pathname to the policy file list. The pathname can be a directory, a filename, a script, or a directive.

A pathname must be enclosed in quotes (") if it contains special characters, such as blank(" "), or a wildcard specification. Use a blank to separate two pathnames, not a comma. `bpplinclude` interprets a comma as part of the pathname; it concatenates two or more comma-delimited pathnames into a single pathname with embedded commas. The command does not verify the syntax or the existence of the pathnames.

`-add -f filename`

Adds all files that are listed in `filename` to the policy file list.

`-delete pathname`

Deletes the specified pathnames from the policy file list. Refer to `-add` for the pathname-list syntax. If you delete a pathname from the policy file list,

you still can recover any backups or archives for that pathname. This option must be the final entry on the command line.

`-delete -f filename`

Deletes all the listed file in *filename* from the policy file list.

`-help`

Prints a command line usage message when `-help` is the only option on the command line.

`-L`

Display the contents of the policy file list in long format.

`-l`

Display the contents of the policy file list in compact format.

Note: The `-l` and `-L` displays are similar.

`-modify {old_path_name new_path_name}`

Modify an entry in the policy file list. The values are a list of pathname pairs `{old_path_name new_path_name}`. For each pathname pair, *new_name_path* replaces *old_name_path* in the policy file list. If no list entry matches *old_path_name*, then *new_path_name* is not entered into the policy file list. Refer to the `-add` option for the pathname syntax. Delimit the list entries with spaces, both within a pathname pair and between pathname pairs. This option must be the final entry on the command line.

`-M master_server, ...`

A list of master servers. This list is a comma-separated list of hostnames. If this option is present, the command is run on each of the master servers in this list. The master servers must allow access by the system that issues the command. If an error occurs for any master server, the process stops at that point in the list. The default is the master server for the system where the command is entered.

`-v`

Select verbose mode for logging. This option is meaningful only when you run with the debug log function on (that is, when the following directory is defined):

install_path\NetBackup\logs\admin

OPERANDS

policy_name

Specifies the policy for which the policy file list is to be set.

EXAMPLES

Example 1

While the backup runs on another master server kiwi, display the policy file list for policy oprdoc_policy on the master server plim:

```
bppllinclude oprdoc_policy -L -M plim
Include:          c:\oprdoc
```

Example 2

Add and delete the pathnames that include one wildcard entry to illustrate bppllinclude's interpretation of wildcards:

```
bppllinclude mkbpolicy -add C:\yap C:\y*
bppllinclude mkbpolicy -L
Include: C:\yap
Include: C:\y*/y*
bppllinclude mkbpolicy -delete C:\y*
bppllinclude mkbpolicy -L
Include: C:\yap
```

Note: bppllinclude does not interpret the wildcard entry y* for -delete as meaning that both yap and y* should be deleted. Only y* is deleted from the include list for mkbpolicy. The interpretation of the wildcard occurs when NetBackup selects files to backup, during the actual backup.

Example 3

Add two entries to the policy file list for a policy, and then modify them:

```
bppllinclude mkbpolicy -add "C:\ima file" "C:\ura file"
bppllinclude mkbpolicy -L
Include: C:\ima file
Include: C:\ura file
bppllinclude mkbpolicy -modify "C:\ima file" "C:\ima file 2" "C:\ura
file" "C:\ura file 2"
bppllinclude mkbpolicy -L
Include: C:\ima file 2
Include: C:\ura file 2
```

Example 4

Add a raw partition to the policy file list for the policy rc (UNIX clients). The full path name for the device is used (the command is all on one line):

```
bppllinclude rc -add /devices/sbus@2,0/dma@2,81000/esp@2,80000/
sd@6,0:h,raw
```

See the Adding UNIX Raw Partitions to the File List section of the *NetBackup Administrator's Guide*.

Example 5

Display the policy file list for the policy mkb_policy:

```
bpplinclude mkb_policy -l  
INCLUDE C:\services  
INCLUDE C:\aliases  
INCLUDE C:\Programs
```

RETURN VALUES

An exit status of 0 means that the command ran successfully.

Any exit status other than 0 means that an error occurred.

If the administrative log function is enabled, the exit status is logged in the administrative daily log under the log directory:

```
install_path\NetBackup\logs\admin
```

It has the following form:

```
bpplinclude: EXIT status = exit status
```

If an error occurred, a diagnostic precedes this message.

FILES

```
install_path\NetBackup\logs\admin\*
```

```
install_path\NetBackup\dv\policy\policy_name\includes
```

SEE ALSO

bpplclients, bpplinfo, bpschedule, bppldelete, bppllist

bpplinfo

NAME

bpplinfo - manage or display policy attributes for NetBackup

SYNOPSIS

```
install_path\NetBackup\bin\admincmd\bpplinfo policy_name -L | -l | -U [-v]
[-M master_server, ...]
```

```
install_path\NetBackup\bin\admincmd\usr/opensv/netbackup/bin/admincmd/bpp
linfo policy_name -set | -modify [-v] [-active | -inactive] [-blkincr
flag] [-chkpt flag] [-chkpt_intrvl interval] [-collect_bmr_info flag]
[-collect_tir_info value] [-compress flag] [-crossmp flag] [-disaster
flag] [-ef effective_time] [-encrypt flag] [-follownfs flag]
[-granular_restore_info 0 | 1] [-job_subtype sub_type [-keyword
"keyword phrase"] [-M master_server, ...] [-multiple_streams flag]
[-policyjobs max_jobs] [-pool label] [-priority priority] [-pt
policy_type] [-residence label] [-rfile flag] [-data_class class |
*NULL*] [-sg server_group | *ANY* | *NONE*] [-ut]
```

```
install_path\NetBackup\bin\admincmd\bpplinfo policy_name -help
```

DESCRIPTION

bpplinfo initializes, modifies, or displays the attribute values for a NetBackup policy. Authorized users can initiate this command.

For more information about NetBackup authorization, refer to the *NetBackup Security and Encryption Guide*.

OPTIONS

bpplinfo consists of two forms. The options that you use with bpplinfo depend on the form of bpplinfo being used.

The first form of bpplinfo displays a policy. The following options apply to this form:

```
policy_name -L | -l | -U
```

List information for this policy. This option is required.

-L specifies a long list type and produces a listing with one policy attribute per line, in the format *policy_attribute: value*. The value can be expressed both in numeric and name form. Fields in the list include:

Policy Type

Active

Follow NFS Mounts (*applies only to NetBackup Enterprise Server*)

Cross Mount Points

Client Compress

Collect TIR Info

Policy Priority

Ext Security Info

File Restore Raw

Client Encrypt

Max Jobs/Policy

Mult. Data Stream

Snapshot

Backup Copy

Disaster Recovery

Collect BMR Info

Max Frag Size

Residence

Volume Pool

Share Group

-l specifies a short list type and produces a terse listing. This option is useful for scripts or the programs that rework the listing contents into a customized report format. A short listing contains the following information for the specified policy:

Line 1: "INFO", client_type, follow_nfs_mounts, client_compress, priority, proxy_client, client_encrypt, disaster_recovery, max_jobs_per_policy, cross_mount_points, max_frag_size, active, collect_tir_info, block_incr, ext_sec_info, i_f_r_f_r, streaming, frozen_image, backup_copy, effective_date, policy ID, number_of_copies, checkpoint, chkpt_interval, policy_info_unused1, pfi_enabled, offhost_backup, use_alt_client, use_data_mover, data_mover_type, collect_bmr_info, res_is_ss, granular_restore_info, job_subtype

Line 2: "KEY", keyword

Line 3: "BCMD", backup_command

Line 4: "RCMD", restore_command

Line 5: "RES", residence

Line 6: "POOL", pool

Line 7: "FOE", this field is not used

-U specifies a user list type and produces a listing with one policy attribute per line, in the format *policy_attribute: value*. This listing is similar to the -L listing, but contains fewer fields.

-v

Selects the verbose mode. This option causes `bplinfo` to log additional information for debugging purposes. The information goes into the NetBackup administration daily debug log. This option is meaningful only when NetBackup enables the debug log function (that is, when the following directory is defined):

```
install_path\NetBackup\logs\admin
```

-M *master_server, ...*

A list of alternative master servers. This list is a comma-delimited list of hostnames. If this option is present, each master server in the list runs the `bplinfo` command. Each master server in the list must allow access by the system that issues the `bplinfo` command. If an error occurs for any master server, the process terminates at that point.

For the display form of `bplinfo`, the report is the composite of the returned information from all the master servers in this list. `bplinfo` queries each of these master servers. The master server returns information from its policy catalog.

For the policy-definition form of `bplinfo`, the policy is created or modified on each master server in the list.

The default is the master server for the system running `bplinfo`.

The second form of `bplinfo` initializes attribute values for a policy or modifies the attribute values for a policy. The following options apply to this form:

Note: Not all options apply to every policy type. For instance, if the policy type is MS-Windows, `bplinfo` accepts the options `-compress` and `-crossmp`. When `bplinfo` completes, it returns a zero status. However, NetBackup handles the policy with the MS-Windows policy type as though the options were not set.

-active | -inactive

Set the policy to active or inactive. If the policy is active, NetBackup runs all its automatic schedules and permits user-directed backups and archives to be used. A policy must be active for an automatic backup to occur (the default).

If the policy is inactive, NetBackup does not run any automatic schedules or permit user-directed schedules to be used. This option is useful to inactivate a policy temporarily to prevent schedules from being used.

`-blkincr flag`

Note: This option applies only if you are running NetBackup Enterprise Server and also have Veritas Oracle Edition, which supports block-level incrementally.

0 (disabled) or 1 (enabled). Perform block-level-incremental backups for clients in this policy.

If 1, do perform block-level-incremental backups.

If 0, do not perform block-level-incremental backups.

`-chkpt [1|0]`

Enables and disables the checkpoint restart for the policy. If 1, the command enables the checkpoint restart. If 0, the command disables the checkpoint restart. The default is 0.

`-chkpt_intrvl interval`

Enables and disables the checkpoint interval for the policy. The variable *interval* is the checkpoint interval in minutes. The default interval is 15 minutes. The range for this interval is between 5 minutes and 180 minutes. If the checkpoint restart is not enabled, then this parameter has no effect.

`-collect_tir_info value`

Collect true-image-recovery (TIR) information. True-image recovery allows NetBackup to restore a directory to exactly what it was at the time of any scheduled full or incremental backup. The files that are deleted before the selected backup time are not restored. After this attribute is enabled, NetBackup starts to collect additional information. It begins with the next full or incremental backup for the policy.

If 0, NetBackup does not keep track of true-image-recovery information.

If 1, NetBackup collects TIR information.

If 2, NetBackup collects TIR information and tracks client files.

`-collect_bmr_info flag`

Collect Bare Metal Restore information.

If *flag* is 0, do not collect Bare Metal Restore information.

If *flag* is 1, collect Bare Metal Restore information.

If `-collect_bmr_info` is set to 1 and Bare Metal Restore is not licensed or the policy type is not Standard or MS-Windows, `bpplinfo` fails.

If `-collect_bmr_info` is set to 1 but the policy does not collect true image restore information with move detection, Bare Metal Restore ignores the following: incremental backups and restore files from the last full backup.

`-compress flag`

0 (disabled) or 1 (enabled). Specifies whether to compress files or not. If 1, the client software compresses the selected files onto the media. Compression may increase total backup time. If 0, the files are not compressed onto the media (the default).

This option has no effect on the hardware compression that may be available on the storage unit.

`-crossmp flag`

0 (disabled) or 1 (enabled). Specifies whether to cross mount points during backups or not.

If 1, NetBackup backs up or archives all files and directories in the selected path, regardless of the file system on which they reside.

If 0, NetBackup backs up or archives only those files and directories on the same file system as the selected file path (the default).

This attribute can affect the Follow NFS policy attribute, which applies only to NetBackup Enterprise Server.

Refer to the *NetBackup Administrator's Guide* for more details.

`-data_class class`

Specifies the data classification (for example, gold or platinum).

`-disaster 0|1`

Collect required information for intelligent disaster recovery. This attribute applies only when you back up Windows clients.

0 = Do not allow disaster recovery (Default)

1 = Allow disaster recovery

`-ef effective time`

This time specifies the time the policy is active.

`-encrypt flag`

Specifies whether files should be encrypted or not. If *flag* is set to 1, encryption is enabled.

`-follownfs flag`

Note: The following `nfs` option applies only to NetBackup Enterprise Server

0 (disabled) or 1 (enabled). Specifies whether to follow NFS mount points or not. For policy types MS-Windows and OS/2, setting this flag affects the policy attribute **Backup Network Drives** instead of the **Follow NFS** attribute.

If 1, NetBackup backs up or archives any NFS-mounted files encountered.

If 0, NetBackup does not back up or archive any NFS-mounted files encountered (the default).

The behavior of this attribute varies depending on the setting of the **Cross Mount Points** attribute.

Refer to the *NetBackup Administrator's Guide* for more details.

`-granular_restore_info flag`

0 (disabled) or 1 (enabled).

If 1, display granular restore information.

If 0, do not display granular restore information.

`-job_subtype DUPLICATE | LIVEUPDATE`

Allows the generic policies for the Duplicate feature or the LiveUpdate feature to be displayed. By default, the policies for these two features are not displayed.

`-keyword "keyword phrase"`

The value is associated with all backups created by using this policy. The keyword phrase can be used to link related policies. It can also be used during restores to search only for the backups that have the keyword phrase association.

`-M master_server,...`

Same as explained earlier.

`-multiple_streams flag`

0 (disabled) or 1 (enabled). Allow Multiple Data Streams.

If 1, allow multiple data streams.

If 0, do not allow multiple data streams.

`policy_name -set | -modify`

Initializes or modifies attributes for this policy. This option is required.

`-set` initializes (or reinitializes) attributes for the policy to their default values, except for those attributes that the options on the current command line set.

`-modify` modifies attributes for the policy. Attributes not explicitly set by options on the current command line do not change their values.

`-pool label`

Specifies the volume pool for the policy. The default is NetBackup. The volume pool should be one of the volume pools for the policy storage unit. This attribute is not relevant if a disk storage unit is the residence for the policy. If the policy storage unit is Any_available (Residence: - appears on the `bplinfo` display), the volume pool for any storage unit can be

selected. If `"*NULL*"` is specified, the volume pool is set to NetBackup. To display the configured volume pools, run the following command:

```
install_path\Volmgr\bin\vmppool -listall
```

`-policyjobs max_jobs`

The maximum number of concurrent jobs that NetBackup allows for this policy (corresponds to the Limit Jobs per Policy setting in the administration interface). `max_jobs` is always greater than or equal to 0.

For the default or when `-policyjobs` is 0, `bpplinfo` sets `max_jobs` to a value that corresponds to unlimited. The effective maximum number of jobs in this instance is 8 for NetBackup and 2003 for NetBackup Enterprise Server.

`-priority priority`

The priority of this policy in relation to other policies. Priority is greater than or equal to 0. This value determines the order in which policies are run. The higher the value, the earlier the policy is run. The default is 0, which is the lowest priority.

`-pt policy_type`

Specify the policy type by entering one of the following character strings (the default is Standard):

Informix-On-BAR

Lotus-Notes

MS-Exchange-Server

MS-SharePoint

MS-SQL-Server

MS-Windows-NT

NDMP

NetWare

Oracle

OS/2

Standard

Sybase

Note that the following policy types apply only to NetBackup Enterprise Server:

AFS

DataTools-SQL-BackTrack

DB2

FlashBackup

FlashBackup-Windows

SAP

Split-Mirror

Vault

`-residence label`

Specifies the label of the storage unit for storing the backups that were created according to this schedule. The default is `Any_available`, which allows the policy to use any storage unit that where the attribute `On Demand Only?` is set to `No`. If the policy needs to use a specific storage unit or the storage unit that is wanted has the attribute `On Demand Only?` set to `Yes`, then specify the storage unit. If `"*NULL*"` is specified, the residence for the schedule is set (or reset) to `Any_available`. The policy residence determines the residence for the policy schedules, unless the `Override Policy Storage Unit` setting on an individual schedule specifies a residence. Run `bpstulist` to display the set of defined storage units.

`-rfile flag`

0 (disabled) or 1 (enabled).

If 1, allow Individual File Restore From Raw.

If 0, do not allow Individual File Restore From Raw.

For a FlashBackup policy, this option is ignored, since the attribute is always enabled.

Note: Advanced Client is available only if you are running NetBackup Enterprise Server and have the separately-priced option.

`-sg [server_group | *ANY* | *NONE*]`

Specifies the server group(s) for the schedule. Do not use this option if the schedule resides on a disk storage unit. If `*NONE*` is specified, the writing media server owns the media that this policy writes. If `*ANY*` is specified, EMM chooses the media owner. `*ANY*` is the default value. Otherwise, the named share group owns the media. Specify a share group for each copy to display the configured share groups. Enter the following command:

```
install_path\NetBackup\bin\admincmd\nbsvrgrp -list -summary
```

`-ut`

If any of the date or the time arguments follow `-ut`, they are accepted as UNIX time, instead of the standard time format. The `-ut` option is used primarily for Java.

The third `bplinfo` form (not in the synopsis) shows usage information and has only one option, as follows:

-help

Prints a command line usage message when `-help` is the only option on the command line.

EXAMPLES

Note: References to NFS Mounts in the following examples apply only to NetBackup Enterprise Server.

Example 1

To set the storage unit of the policy `tstpolicy` to `tstunit` and view the results, perform the following:

```
bplinfo tstpolicy -modify -residence tstunit
bplinfo tstpolicy -L
Policy Type:                Standard (0)
Active:                      no
Effective:                   no
Follow NFS Mounts:          no
Cross Mount Points:          no
Client Compress:             no
Collect TIR Info:            no
Policy Priority:              0
Ext Security Info:           no
File Restore Raw:            no
Client Encrypt:              no
Max Jobs/Policy:             8
Mult. Data Streams:          1
Block Level Incremental:     no
Perform Snapshot Backup:     no
Backup Copy:                  0
Date Mover Type:             2
Use Alternate Client:         no
Alternate Client Name:        (none)
Enable Instant Recovery:     no
Disaster Recovery:           0
Collect BMR Info:            no
Max Frag Size:               0 MB (1048576 MB)
Checkpoint Restart:          no
Residence:                    tstunit
Volume Pool:                  NetBackup
```

Example 2

To return the attributes of `tstpolicy` to their default values, perform the following:

```
bplinfo tstpolicy -set
bplinfo tstpolicy -L
Policy Type:                Standard (0)
Active:                      yes
```

```

Follow NFS Mounts: no
Cross Mount Points: no
Client Compress: no
Collect TIR Info: no
Policy Priority: 0
Ext Security Info: no
File Restore Raw: no
Client Encrypt: no
Multiple Streams: 0
Disaster Recovery: 0
Max Jobs/Policy: 8
Disaster Recovery: 0
Collect BMR Info: no
Max Frag Size: 0 MB (1048576 MB)
Residence: -
Volume Pool: NetBackup
  
```

Example 3

The following is an example of a short listing for the policy that is named mkbpolicy:

```

bpplinfo mkbpolicy -l
INFO 0 0 0 0 *NULL* 0 0 99 0 0 0 0 0 0 0 *NULL* 1
KEY my temp directory
BCMD *NULL*
RCMD *NULL*
RES mkbunit *NULL* *NULL* *NULL* *NULL* *NULL* *NULL* *NULL* *NULL*
POOL NetBackup *NULL* *NULL* *NULL* *NULL* *NULL* *NULL* *NULL* *NULL*
*NULL*
FOE 0 0 0 0 0 0 0 0 0 0
  
```

FILES

```

install_path\NetBackup\logs\admin/*
install_path\NetBackup\db\policy\policy_name\info
  
```

bplist

NAME

bplist - list policy information

SYNOPSIS

```
install_path\NetBackup\bin\admincmd\bplist [policyname] [-L | -l | -U]  
[-allpolicies] [-M master_server,...] [-hwos] [-byclient client]  
[-keyword "keyword phrase"] [-verbose]
```

DESCRIPTION

bplist lists policies within the NetBackup database.

Any authorized users can initiate this command.

For more information about NetBackup authorization, refer to the *NetBackup Security and Encryption Guide*.

OPTIONS

-allpolicies

Lists all policies.

-hwos

Lists possible hardware and the operating system.

-L

Displays a full listing.

-l

Displays the information in raw output mode.

-M master_server,...

Lists the policy information for one or more specified master.

-U

Displays the information in the style that xbpadm uses.

-byclient client

Lists the policy information for all policies that contain the client indicated.

-inventory

Creates an inventory of the current NetBackup policies and compares it to the previously created inventory. You can create touch file LOG_CLASS_QUERIES in /usr/openv/netbackup to log changes to policies.

The changes are logged in `/usr/opensv/netbackup/logs/PolicyQueries.log`. The customer is responsible for the administration of the log file (periodic truncation, etc.).

`-keyword "keyword phrase"`

The value is associated with all backups created by using this policy. The keyword phrase can be used to link related policies. It can also be used during restores to search only for the backups that have the keyword phrase association.

`policyname`

Specifies the policy in the NetBackup database.

`-verbose`

Selects verbose mode for logging.

bppsched

NAME

bppsched - add, delete, or list NetBackup schedules

SYNOPSIS

```

install_path\NetBackup\bin\admincmd\bppsched policy_name [-v] [-M
  master_server...] [-L | -l | -U] [-label sched_label]

install_path\NetBackup\bin\admincmd\bppsched policy_name [-v] [-M
  master_server...] -delete sched_label ...

install_path\NetBackup\bin\admincmd\bppsched policy_name [-v] [-M
  master_server...] -deleteall

install_path\NetBackup\bin\admincmd\bppsched policy_name [-v] [-M
  master_server...] -add sched_label [-st sched_type] [-freq frequency]
  [-mpxmax mpx_factor] [-number_copies number] [-synthetic 0|1]
  [-pfi_fast_recovery 0|1] [-rl retention_level
  [,rl_copy2,...,rl_copyn]] [-residence storage_unit_label
  [,stunit_copy2,...,stunit_copyn]] [-pool volume_pool_label
  [,pool_copy2,...,pool_copyn]] [-res_is_stl 0|1] [-fail_on_error
  0|1[,0|1,...,0|1]] [-sg share_group [,share_copy2,...,share_copyn]
  [-window start_duration] [-cal 0|1|2] [-ut] [-incl mm/dd/yyyy] [-excl
  mm/dd/yyyy] [-weekday day_name_week] [-dayomonth value | 1]

```

DESCRIPTION

bppsched does one of the following:

- Add a new schedule to a policy.
- Delete one or more schedules from a policy.
- Delete all the schedules from a policy.
- List one or all schedules in a policy.

For the `-add` and `-delete` options, bppsched returns to the system prompt immediately after it submits the schedule change request to NetBackup. To determine whether the change was successful, run bppsched again to list the updated schedule information.

When the listing option is used, a single entry for each schedule appears even if the `-M` option is used. The `-l` form lists the information for each schedule on several lines. `-l` does not identify the attributes by name; these are as follows (where the names are not described; they are reserved for internal NetBackup use):

Line 1: SCHED, schedule name, type, max_mpx, frequency, retention level, u_wind/o/d, 2 internal attributes, maximum fragment size, calendar, number of copies, and fail on error. Note that u_wind/o/d is a field reserved for future use. The u_wind entry in the -L display is also reserved for future use.

Line 2: SCHEDWIN, seven pairs of the form *start, duration*, which expresses the start and duration of the window for each day of the week. It starts with Sunday.

Line 3: SCHEDRES, residence (a value for each copy).

Line 4: SCHEDPOOL, pool (a value for each copy).

Line 5: SCHEDRL, retention level (a value for each copy).

Line 6: SCHEDFOE, fail on error (a value for each copy).

If the -M option is used, bppsched performs the operation on each of the master servers that are listed. For instance, if bppsched adds a schedule, bppsched adds the schedule to the policy on each of the master servers that is listed for -M. If -M is used on a listing request, the listing is composed of returned information from all of the master servers in the -M list. If the command fails for any of the master servers, activity stops at that point.

To modify an existing NetBackup schedule, use the NetBackup command bppschedrep.

Authorized users can initiate this command.

For more information about NetBackup authorization, refer to the *NetBackup Security and Encryption Guide*.

OPTIONS

These options are common to all forms of bppsched:

policy_name

The name of the policy that contains the schedules. The policy must exist before you run this command. This option is required, and must be the first one on the command line.

-help

Prints a command line usage message when -help is the only option on the command line.

-M *master_server, . . .*

A list of alternative master servers. This list is a comma-separated list of host names. If this option is present, each master server in the list runs the bppsched command. Each master server in the list must allow access by the system that issues the bppsched command.

If this option is present, the command is run on each master server in the list. If an error occurs for any master server, the process terminates at that point.

If `bppsched` produces a listing, the listing is the composite of the returned information from all the master servers in this list.

If `bppsched` adds or deletes a schedule, all master servers in this list receive the change.

-v

Selects the verbose mode. This option causes `bppsched` to log additional information for debugging purposes. The information goes into the NetBackup administration debug log. This option is meaningful only when NetBackup enables the debug log function (that is, when the following directory is defined):

```
install_path\NetBackup\logs\admin
```

The remaining options depend on the form of `bppsched`. The first form of `bppsched` adds a schedule to the named policy. The following options apply to this form of `bppsched`:

`-add sched_label [suboptions]`

Add a single schedule to the named policy.

The sub-options for the `-add` option are explained later in this description. These are attributes of the schedule being added.

Refer to the *NetBackup Administrator's Guide* for details on schedules and their attributes.

`-cal 0|1|2`

Indicates whether `bppsched` follows a calendar-based schedule or a frequency-based schedule.

0 = frequency-based schedule

1 = calendar-based schedule with no retries after run day

2 = calendar-based schedule with retries after run day

`-dayomonth value | 1`

Specifies the day of every month to run the schedule. Enter `l` (lowercase L) to run the last day of every month, whether the month contains 28, 29, 30, or 31 days.

For example, to run the schedule the 15th day of every month, enter:

```
-dayomonth 15
```

To run the last day of every month, enter:

```
-dayomonth l
```

`-excl mm/dd/yyyy`

Indicates to exclude this single date.

`-fail_on_error 0|1[,0|1,...,0|1]`

Specifies whether to fail all other copies if one copy fails. If no parameter is specified, 0 is default for all copies. Specify a value for each copy.

0 = Do not fail the other copies

1 = Fail other copies

`-freq frequency`

Determines how often backups run. Represents the number of seconds between the backups that are initiated according to this schedule. When it is omitted on the command line, the default value is 604800 (duration of one week in seconds).

`-incl mm/dd/yyyy`

Indicates to include this single date.

`-mpxmax mpx_factor`

The maximum number of jobs for this schedule that NetBackup multiplexes on any one drive. *mpx_factor* is an integer that can range from 1 through 8 for NetBackup Server and 1 through 32 for NetBackup Enterprise Server. A value of 1 means that backups for this schedule are not multiplexed. The default is no multiplexing.

`-number_copies number`

Specify the number of simultaneous backup copies. The minimum value is 1. The maximum value is 4 or the Maximum Backup Copies global parameter, whichever is smaller. The default is 1.

`-pfi_fast_recovery 0|1`

Enables the user to turn on the feature to retain snapshots for Instant Recovery. The default value is 0, which means this feature is disabled. A value of 1, enables this feature.

`-pool volume_pool_label[,pool-copy2,... pool-copyn]`

The name of the volume pool. This choice overrides the policy-level volume pool. If you enter `"*NULL*"`, NetBackup uses the volume pool that is specified at the policy level. The default is to use the volume pool that is specified at the policy level. The volume pool label cannot be None. If you do not specify a volume pool at either the schedule level or the policy level, NetBackup uses a default value of NetBackup.

When you specify `-number_copies` greater than 1, specify a pool for each copy.

`-res_is_stl`

Identifies that the data in the storage unit is storage lifecycle.

`-residence storage_unit_label[,stunit-copy2,... stunit-copyn]`

The name of the storage unit, which specifies the location of the backup images. The value `"*NULL*"` causes NetBackup to use the storage unit that is specified at the policy level. The default is for NetBackup to use the storage unit that is specified at the policy level. If you do not specify a storage unit at either the schedule level or the policy level, NetBackup uses the next storage unit available.

When you specify `-number_copies` greater than 1, specify a residence for each copy.

`-rl retention_level[,rl-copy2,..., rl-copyn]`

The retention level determines how long to retain backups and archives. The `retention_level` is an integer between 0 and 24. The default retention level is 1. Valid retention levels and their corresponding default retention times are listed later in this description.

When you specify `-number_copies` greater than 1, specify a retention level for each copy.

CAUTION: You can change the retention period that is associated with each level by using the NetBackup administration interface. Therefore, your configuration may have different values for each level than those shown here. Use the NetBackup administration interface to determine the actual retention periods before you make any changes with this command. Otherwise, backups can expire sooner than you expect, which results in loss of data.

0	1 week
1	2 weeks
2	3 weeks
3	1 month
4	2 months
5	3 months
6	6 months
7	9 months
8	1 year
9 - 24	infinite

`-sg share_group [,share_copy2,...share_copyn]`

Specifies the share group(s) for the schedule. Do not use this option if the schedule resides on a disk storage unit. If `*NONE*` is specified, the writing media server owns the media that this policy writes. If `*ANY*` is specified, EMM chooses the media owner. `*ANY*` is the default value. Otherwise, the

named share group owns the media. Specify a share group for each copy to display the configured share groups. Enter the following:

```
install_path\NetBackup\bin\admincmd\nbsvrgrp -list -summary
```

`-st sched_type`

The type of the schedule. The default schedule type is FULL. The following list contains the possible values for this attribute with their meanings:

FULL - full

INCR - differential incremental

CINC - cumulative incremental

UBAK - user backup

UARC - user archive

`-synthetic 0|1`

Enables the user to determine which schedule occurs. A value of 0 means the schedule is a real (non-synthetic) backup schedule. (0 is the default.) A value of 1 means the schedule is a synthetic backup schedule.

`-ut`

If any of the date or the time arguments follow `-ut`, they are accepted as UNIX time, instead of the standard time format. The `-ut` option is used primarily for Java.

`-weekday day_name week`

Specifies a day of the week, and the week of the month, as a run day in the schedule.

The *day_name* is: Sunday, Monday, Tuesday, Wednesday, Thursday, Friday, or Saturday.

The *week* is the number of the week in the month.

For example, to instruct the policy to run the second Monday of the month, enter:

```
-weekday Monday 2
```

`-window start duration`

Specifies when NetBackup can run the backups for this schedule. Every day of the week has the same window.

start is the time at which the backup window opens for this schedule. This time is the number of seconds since midnight. This number is an integer between 0 and 86399 (86400 seconds in a day).

duration is the length of time that the window remains open. The time unit is seconds. This unit is a non-negative integer.

The second form of `bppsched` deletes one or more schedules from the named policy. The following option applies to this form of `bppsched`:

`-delete sched_label`

Delete the listed schedules from the named policy. Separate the elements of the `sched_label` list with spaces. There can be up to 25 labels in the list.

The third form of `bppsched` deletes all schedule from the named policy. The following option applies to this form of `bppsched`:

`-deleteall`

Delete all schedules from the named policy.

The fourth form of `bppsched` produces a listing of information about the schedules for the named policy. The following options apply to this form of `bppsched`:

`-l`

The list type is short, (the default list type). This option produces a terse listing that includes all attributes for the schedule. Each schedule occupies one line of the listing. Most attribute values are expressed numerically. This option is useful for scripts or the programs that rework the listing contents into a customized report format.

`-L`

The list type is long. This listing includes all attributes for the schedule. Some attribute values are descriptive terms, rather than numbers.

`-label sched_label`

List the attributes for this schedule in the named policy. The default is to list information for all schedules for the named policy.

`-U`

The list type is user. This listing is similar to the long-type list, but it has fewer entries. Most attribute values are descriptive terms, rather than numbers.

EXAMPLES

Example 1

In this example, `bppsched` lists the information for schedule `user` within policy `tstpolicy` in two different ways. The first display is in long mode. The second is in User mode, which shows fewer entries than the Long mode display.

```
bppsched tstpolicy -L -label user
Schedule:          user
Type:              UBAK (2)
Frequency:         1 day(s) (86400 seconds)
Retention Level:  0 (1 week)
u-wind/o/d:        0 0
Incr Type:         DELTA (0)
Incr Depends:     (none defined)
Max Frag Size:0 MB (1048576 MB)
```

```

Maximum MPX: 1
Number copies:1
Fail on Error:0
Residence:      (specific storage unit not required)
Volume Pool:    (same as policy volume pool)
Daily Windows:
Day      Open      Close      W-Open      W-Close
Sunday   000:00:00  024:00:00  000:00:00  024:00:00
Monday   000:00:00  024:00:00  024:00:00  048:00:00
Tuesday  000:00:00  024:00:00  048:00:00  072:00:00
Wednesday 000:00:00  024:00:00  072:00:00  096:00:00
Thursday 000:00:00  024:00:00  096:00:00  120:00:00
Friday   000:00:00  024:00:00  120:00:00  144:00:00
Saturday 000:00:00  024:00:00  144:00:00  168:00:00
  
```

```

bpspsched tstpolicy -U -label user
Schedule:      user
Type:          User Backup
Retention Level: 0 (1 week)
Maximum MPX:   1
Number copies:1
Fail on Error:0
Residence:      (specific storage unit not required)
Volume Pool:    (same as policy volume pool)
Daily Windows:
Sunday  00:00:00  -->  Sunday  24:00:00
Monday  00:00:00  -->  Monday  24:00:00
Tuesday 00:00:00  -->  Tuesday 24:00:00
Wednesday 00:00:00 -->  Wednesday 24:00:00
Thursday 00:00:00 -->  Thursday 24:00:00
Friday  00:00:00  -->  Friday  24:00:00
Saturday 00:00:00 -->  Saturday 24:00:00
  
```

Example 2

While in operation on the system hatt, list information for the schedule named full in policy tstpolicy, as defined on the master server beaver:

```

bpspsched tstpolicy -M beaver -L -label full
Schedule:      full
Type:          FULL (0)
Frequency:     0+ day(s) (14400 seconds)
Retention Level: 0 (1 week)
u-wind/o/d:    0 0
Incr Type:     DELTA (0)
Incr Depends:  (none defined)
Max Frag Size: 0 MB (1048576 MB)
Maximum MPX:   1
Number copies:1
Fail on Error:0
Residence:      (specific storage unit not required)
Volume Pool:    (same as policy volume pool)
Daily Windows:
Day      Open      Close      W-Open      W-Close
  
```

Sunday	000:00:00	024:00:00	000:00:00	024:00:00
Monday	000:00:00	024:00:00	024:00:00	048:00:00
Tuesday	000:00:00	024:00:00	048:00:00	072:00:00
Wednesday	000:00:00	024:00:00	072:00:00	096:00:00
Thursday	000:00:00	024:00:00	096:00:00	120:00:00
Friday	000:00:00	024:00:00	120:00:00	144:00:00
Saturday	000:00:00	024:00:00	144:00:00	168:00:00

Example 3

The following example adds a new schedule, `full_2`, to the policy `tstpolicy` on `beaver`, and then lists the new schedule in Long mode. These commands run on the system `hatt`:

```
bppsched tstpolicy -M beaver -add full_2
bppsched tstpolicy -M beaver -label full_2 -L
Schedule:          full_2
Type:              FULL (0)
Frequency:         7 day(s) (604800 seconds)
Retention Level:  1 (2 weeks)
u-wind/o/d:       0 0
Incr Type:        DELTA (0)
Incr Depends:     (none defined)
Max Frag Size:    0 MB (1048576 MB)
Maximum MPX:      1
  Number copies:  1
  Fail on Error:  0
  Residence:      (specific storage unit not required)
Volume Pool:      (same as policy volume pool)
Daily Windows:
Day      Open      Close      W-Open      W-Close
Sunday   000:00:00  000:00:00
Monday   000:00:00  000:00:00
Tuesday  000:00:00  000:00:00
Wednesday 000:00:00  000:00:00
Thursday 000:00:00  000:00:00
Friday   000:00:00  000:00:00
Saturday 000:00:00  000:00:00
```

Example 4

In this example, `bppsched` deletes the schedules, `full_3`, `user`, `user_2`, and `user_3` from policy `tstpolicy`:

```
bppsched tstpolicy -delete full_3 user user_2 user_3
```

Example 5

In this example, `bppsched` lists the schedule information for policy `tstpolicy`:

```
bppsched tstpolicy -L
Schedule:          full
Type:              FULL (0)
Frequency:         1 day(s) (86400 seconds)
Retention Level:  0 (1 week)
u-wind/o/d:       0 0
Incr Type:        DELTA (0)
```

```
Incr Depends:      (none defined)
Max Frag Size:    0 MB (1048576 MB)
Maximum MPX:      1
  Number copies:1
  Fail on Error:0
  Residence:      (specific storage unit not required)
Volume Pool:      (same as policy volume pool)
Daily Windows:
Day              Open           Close          W-Open         W-Close
Sunday           000:00:00      024:00:00      000:00:00      024:00:00
Monday           000:00:00      024:00:00      024:00:00      048:00:00
Tuesday          000:00:00      024:00:00      048:00:00      072:00:00
Wednesday        000:00:00      024:00:00      072:00:00      096:00:00
Thursday         000:00:00      024:00:00      096:00:00      120:00:00
Friday           000:00:00      024:00:00      120:00:00      144:00:00
Saturday         000:00:00      024:00:00      144:00:00      168:00:00
```

```
Schedule:          user
Type:              UBAK (2)
Frequency:         1 day(s) (86400 seconds)
Retention Level:  0 (1 week)
u-wind/o/d:        0 0
Incr Type:         DELTA (0)
Incr Depends:      (none defined)
Max Frag Size:    0 MB (1048576 MB)
Maximum MPX:      1
  Number copies:1
  Fail on Error:0
  Residence:      (specific storage unit not required)
Volume Pool:      (same as policy volume pool)
Daily Windows:
Day              Open           Close          W-Open         W-Close
Sunday           000:00:00      024:00:00      000:00:00      024:00:00
Monday           000:00:00      024:00:00      024:00:00      048:00:00
Tuesday          000:00:00      024:00:00      048:00:00      072:00:00
Wednesday        000:00:00      024:00:00      072:00:00      096:00:00
Thursday         000:00:00      024:00:00      096:00:00      120:00:00
Friday           000:00:00      024:00:00      120:00:00      144:00:00
Saturday         000:00:00      024:00:00      144:00:00      168:00:00
```

Example 6

In this example, bppsched adds a new schedule, full, with a window from 11 pm to midnight. The second bppsched lists the information for schedule full:

```
bppsched elevenpm -add full -window 82800 3600
bppsched elevenpm -U -label full
Schedule:          FULL (0)
Type:              Full Backup
Frequency:         every 7 days (604800 seconds)
Retention Level:  1 (2 weeks)
Maximum MPX:      1
```

```
Number copies:1
Fail on Error:0
Residence:      (specific storage unit not required)
Volume Pool:    (same as policy volume pool)
Daily Windows:
  Sunday      23:00:00 --> Sunday      24:00:00
  Monday      23:00:00 --> Monday      24:00:00
  Tuesday     23:00:00 --> Tuesday     24:00:00
  Wednesday   23:00:00 --> Wednesday   24:00:00
  Thursday    23:00:00 --> Thursday    24:00:00
  Friday      23:00:00 --> Friday      24:00:00
  Saturday    23:00:00 --> Saturday    24:00:00
```

FILES

```
install_path\NetBackup\logs\admin\*
install_path\NetBackup\db\policy\policy_name\schedule
```

SEE ALSO

bppschedrep

bppschedrep

NAME

bppschedrep - modify NetBackup schedule attributes

SYNOPSIS

```
install_path\NetBackup\bin\admincmd\bppschedrep policy_name sched_label
[-M master_server,...] [-v] [-st sched_type] [-freq
backup_frequency] [-mpxmax mpx_factor] [-cal 0|1|2] [-incl mm/dd/yyyy]
[-excl mm/dd/yyyy] [-delincl mm/dd/yyyy] [-delexcl mm/dd/yyyy]
[-weekday day_name week] [-dayomonth 1-31|1] [-delweekday day_name
week] [-deldayomonth 1-31|1] [-ci] [-ce] [-cw] [-cd] [-number_copies
number] [-rl retention_level[,rl_copy2,...,rl_copyn]] [-fail_on_error
0|1[,0|1,...,0|1]] [-residence storage_unit_label
[,stunit_copy2,...stunit_copyn]] [-pool volume_pool_label
[,pool_copy2,...pool_copyn]] [-sg share_group
[,share_copy2,...share_copyn]] [-(0..6) start duration] [-res_is_stl
0|1]
```

DESCRIPTION

bppschedrep changes the attributes of a NetBackup schedule. The schedule and policy that bppschedrep names should already exist when this command is run. If the -M option is used, bppschedrep changes the schedule on each of the listed master servers.

Any authorized user can initiate this command.

For more information about NetBackup authorization, refer to the *NetBackup Security and Encryption Guide*.

OPTIONS

-(0..6) *start duration*

Specifies the window during which NetBackup can run the backups for this schedule. This window applies to a specific day of the week. 0 corresponds to Sunday, 1 to Monday, and so on.

start is the time at which the backup window opens for this schedule. This time is the number of seconds since midnight. It is an integer between 0 and 86400 (the number of seconds in a day).

duration is the length of time that the window remains open. The time unit is seconds. This unit is a non-negative integer.

`-cal 0|1|2`

Indicates whether `bppschedrep` follows a calendar-based schedule or a frequency-based schedule.

0 = frequency-based schedule

1 = calendar-based schedule with no retries after run day

2 = calendar-based schedule with retries after run day

`-dayomonth 1-31|1`

Specifies the day of every month to run the schedule. Enter 1 (lowercase L) to run the last day of every month, whether the month contains 28, 29, 30, or 31 days.

For example, to run the schedule the 15th day of every month, enter:

`-dayomonth 15`

To run the last day of every month, enter:

`-dayomonth 1`

`-deldayomonth 1-31|1`

Specifies a day of every month to exclude as a run day. Enter 1 (lowercase L) to exclude the last day of every month, whether the month contains 28, 29, 30, or 31 days. This command can only remove the dates that were added by using the `-dayomonth` command.

For example, to exclude the 20th day of every month from the schedule, enter:

`-deldayomonth 20`

`-delweekday day_name week`

Specifies a day of the week and the week of the month to exclude as a run day from the schedule. This command can only remove the dates that were added by using the `-weekday` command.

The *day_name* is: Sunday, Monday, Tuesday, Wednesday, Thursday, Friday, or Saturday.

The *week* is the number of the week in the month.

For example, to exclude the second Monday of the month, enter:

`-delweekday Monday 2`

`-excl mm/dd/yyyy`

Indicates to exclude this single date.

`-delincl mm/dd/yyyy`

Indicates to delete this single date. This command can only remove the dates that were added by using the `-incl` command.

- `-delexcl mm/dd/yyyy`
Indicates to delete this single date.
- `-ci`
Clear all specific include dates.
- `-ce`
Clear all specific exclude dates.
- `-cw`
Clear all week days.
- `-cd`
Clear all days of a month.
- `-fail_on_error 0|1[,0|1,...,0|1]`
Specifies whether to fail all other copies if one copy fails. If no parameter is specified, 0 is default for all copies. Specify a value for each copy.
0 = Do not fail the other copies
1 = Fail other copies
- `-freq backup_frequency`
The backup frequency controls how much time can elapse between successful automatic backups for clients on this schedule. Frequency does not apply to user schedules because the user can perform a backup or archive any time the backup window is open. This value is a positive integer that represents the number of seconds between successful automatic backups for this schedule.
- `-help`
Prints a command line usage message when `-help` is the only option on the command line.
- `-incl mm/dd/yyyy`
Indicates to include this single date.
- `-M master_server, ...`
A list of alternative master servers. This list is a comma-separated list of hostnames. If this option is present, each master server in the list runs the `bppschedrep` command. Each master server in the list must allow access by the system that issued the `bppschedrep` command. If an error occurs for any master server, the process terminates at that point.
The schedule attributes is modified on all the master servers in this list.
- `-mpxmax mpx_factor`
The maximum multiplexing factor for this schedule. Multiplexing sends concurrent, multiple backups from one or several clients to a single drive.

The multiplexing factor can range from 1 through 8 for NetBackup Server and 1 through 32 for NetBackup Enterprise Server. A value of 1 specifies no multiplexing and a value greater than 1 means that NetBackup should create multiplexed images on the destination media. The multiplexing factor should be less than or equal to the multiplexing factor for the storage unit.

For more information on multiplexing, refer to the multiplexing topic in the *NetBackup Administrator's Guide*.

`-number_copies number`

Specify the number of simultaneous backup copies. The minimum value is 1. The maximum value is 4 or the Maximum Backup Copies global parameter, whichever is smaller. The default is 1.

`policy_name`

The name of the policy that contains the schedule. This policy has been previously created.

`-pool volume_pool_label[,pool-copy2,... pool-copyn]`

Specifies the volume pool(s) for the schedule. Do not use this option if a disk storage unit is the residence for the schedule. If `"*NULL*"` is specified, the volume pool for the schedule is the volume pool of the policy that contains this schedule.

Specify a pool for each copy.

To display the configured volume pools, run the following command:

```
install_path\Volmgr\bin\vmppool -listall -listall
```

`-res_is_stl 0 | 1`

Identifies that the data in the storage unit is storage lifecycle.

`-residence storage_unit_label[,stunit-copy2,... stunit-copyn]`

Specifies the label(s) of the storage unit to be used for storing the backups that were created according to this schedule. If `"*NULL*"` is specified, the residence for the schedule defaults to the residence of the policy that contains this schedule. If the residence value is a storage unit label, the residence for the schedule becomes that storage unit and overrides the residence for the policy.

Specify a storage unit for each copy.

Run `bpstulist` to display the set of defined storage units.

`-rl retention_level[,rl-copy2,..., rl-copyn]`

Specifies how long NetBackup retains the backups that it creates by using this schedule. Valid retention levels and their corresponding default retention times are listed later in this description.

Specify a retention level for each copy.

CAUTION: You can change the retention period that is associated with each level by using the NetBackup administration interface. Therefore, your configuration may have different values for each level than those shown here. Use the NetBackup administration interface to determine the actual retention periods before you make any changes with this command. Otherwise, backups can expire sooner than you expect, which results in loss of data.

0 1 week
1 2 weeks
2 3 weeks
3 1 month
4 2 months
5 3 months
6 6 months
7 9 months
8 1 year
9 - 24 infinite

NetBackup keeps the information about the backups for the specified time. Then it deletes information about them. Once the information is deleted, the files in the backups are unavailable for restores. When all the backups on a volume have expired, the volume can be reassigned.

sched_label

Specifies the name of the schedule to be changed. This schedule has been previously created.

-sg share_group [,share_copy2, ...share_copyn]

Specifies the share group(s) for the schedule. Do not use this option if the schedule resides on a disk storage unit. If *NONE* is specified, the writing media server owns the media that this policy writes. If *ANY* is specified, EMM chooses the media owner. *ANY* is the default value. Otherwise, the named share group owns the media. Specify a share group for each copy to display the configured share groups. Enter the following:

```
install_path\NetBackup\bin\admincmd\nbsvrgrp -list -summary
```

-st sched_type

Specifies the type of backup this schedule performs. Schedule types fall into two main categories: automatic and user. Automatic schedules define the windows during which the NetBackup scheduler can initiate a backup for this policy.

User schedules define the windows during which a user can initiate a backup or archive.

The values for schedule type are

FULL (full backup)
 INCR (differential incremental backup)
 CINC (cumulative incremental backup)
 UBAK (user backup)
 UARC (user archive)

`-weekday day_name week`

Specifies a day of the week, and the week of the month, as a run day in the schedule.

The *day_name* is: Sunday, Monday, Tuesday, Wednesday, Thursday, Friday, or Saturday.

The *week* is the number of the week in the month.

For example, to instruct the policy to run the second Monday of the month, enter:

`-weekday Monday 2`

`-v`

Selects the verbose mode. This option causes `bppschedrep` to log additional information for debugging purposes. The information goes into the NetBackup administration daily debug log. This option is meaningful only when NetBackup enables the debug log function (that is, when the following directory is defined):

`install_path\NetBackup\logs\admin`

EXAMPLES

Example 1

Set the frequency for a schedule.

```
bppschedrep mkbpolicy incr -freq 604800
```

This sets to 1 week the frequency with which automatic backups are performed for the schedule `incr` in policy `mkbpolicy`.

Example 2

For Saturday and Sunday of each week, have the window for schedule `full` in policy `newpolicy` open at 10 pm instead of 11 pm. Also, set the window duration to 2 hours instead of 1 hour. `bppschedrep` resets the windows, and `bppsched` lists the new schedule values.

```
bppschedrep newpolicy full -0 79200 7200 -6 79200 7200
```

```
bppsched newpolicy -U -label full
```

```
Schedule:          full
Type:              Full Backup
Frequency:         every 7 days
Retention Level:  1 (2 weeks)
```

Maximum MPX: 1
Residence: (specific storage unit not required)
Volume Pool: (same as policy volume pool)
Daily Windows:
 Sunday 22:00:00 --> Sunday 24:00:00
 Monday 23:00:00 --> Monday 24:00:00
 Tuesday 23:00:00 --> Tuesday 24:00:00
 Wednesday 23:00:00 --> Wednesday 24:00:00
 Thursday 23:00:00 --> Thursday 24:00:00
 Friday 23:00:00 --> Friday 24:00:00
 Saturday 22:00:00 --> Saturday 24:00:00

FILES

install_path\NetBackup\logs\admin\
install_path\NetBackup\db\policy*policy_name*\schedule

SEE ALSO

bpplsched

bppolicynew

NAME

bppolicynew - create, copy, or rename a NetBackup policy

SYNOPSIS

```
install_path\NetBackup\bin\admincmd\bppolicynew policy_name [-verbose]
[-M master_server,...]

install_path\NetBackup\bin\admincmd\bppolicynew policy_name -sameas
existing_policy_name [-verbose] [-M master_server,...]

install_path\NetBackup\bin\admincmd\bppolicynew existing_policy_name
-renameto policy_name [-verbose] [-M master_server,...]
```

DESCRIPTION

bppolicynew performs one of the following operations on a NetBackup policy:

- Create a new policy with default attribute values
- Create a new policy with the same attributes as an existing policy
- Rename an existing policy

When `bppolicynew` runs without `-sameas` or `-renameto`, it creates a new NetBackup policy with default attribute values. If `-M` is present, the defaults that are used for the policy definition on each master server are the defaults for that master server.

`bppolicynew` copies a policy by adding a new policy to the NetBackup database. The clients, files, schedules, and attributes for the new policy are the same as those for the existing policy. `bppolicynew` does not create a policy copy with the same name as an existing policy.

If `bppolicynew` renames a policy, the existing association of images with the policy is lost. This means that the images that were created before the policy was renamed are not included in a list of images for the renamed policy. The command does not rename a policy with the same name as an existing policy.

`bpplinfo` replaces the policy-attribute defaults with new values.

`bpplclients`, `bpplinclude`, and `bpplsched` define the clients, backup files, and schedules for the policy. A policy needs to have at least one client, one file specification, and one automatic schedule before it can run automatic backups.

`bppolicynew` sends its error messages to `stderr`. `bppolicynew` sends a log of its activity to the NetBackup admin log file for the current day.

Authorized user can initiate this command.

For more information about NetBackup authorization, refer to the *NetBackup Security and Encryption Guide*.

See the *NetBackup Administrator's Guide* for additional information on policies.

OPTIONS

policy_name

Specifies the name of a NetBackup policy that `bppolicynew` creates or the name to which `bppolicynew` changes an existing policy. The option has no default value.

This policy name must differ from any existing policy name. It is composed of numeric, alphabetic, plus, minus, underscore, and period characters. Do not use a minus as the first character or leave spaces between characters.

existing_policy_name

The name of a NetBackup policy that already exists when `bppolicynew` runs. The option does not have a default value.

`-renameto`

Change the name of the existing policy to the new policy name.

`-sameas`

Create a new policy by copying its characteristics from the existing policy.

`-help`

Prints a command line usage message.

`-M master_server, . . .`

Specifies a list of comma-separated master server hostnames. If this option is present, the command is run on each of the master servers in this list. The servers must allow access by the system that issued the command. If an error occurs, the process stops at that point in the list. The default is the master server for the system where the command is entered.

`-verbose`

Select verbose mode for logging. This option is meaningful only when it runs with the debug log function (that is, when the following directory is defined):

`install_path\NetBackup\logs\admin`

EXAMPLES

Note that references to Follow NFS Mounts in these examples apply only to NetBackup Enterprise Server.

Example 1

Create a policy with default attribute values on the master server `plim`:

```
bppolicynew ishkabibble -M plim  
bppllist ishkabibble -U -M plim
```

```
-----  
Policy Name:          ishkabibble  
Policy Type:          Standard  
Active:               yes  
Client Compress:      no  
Follow NFS Mounts:    no  
Cross Mount Points:   no  
Collect TIR info:     no  
Block Incremental:    no  
Mult. Data Streams:   no  
Client Encrypt:       no  
Policy Priority:       0  
Max Jobs/Policy:      99  
Disaster Recovery:    0  
Residence:            (specific storage unit not required)  
Volume Pool:          NetBackup  
Keyword:              (none specified)  
  
Clients:              (none defined)  
  
Include:              (none defined)  
  
Schedule:            (none defined)
```

Example 2

Create a new policy, `mypolicy_copy` from the existing policy `mypolicy`. `bppllist` shows that `mypolicy_copy` has the same attributes as `mypolicy`. For brevity, most of the schedule information is omitted here:

```
bppolicynew mypolicy_copy -sameas mypolicy  
bppllist mypolicy -U
```

```
-----  
Policy Name:          mypolicy  
Policy Type:          Standard  
Active:               yes  
Client Compress:      no  
Follow NFS Mounts:    no  
Cross Mount Points:   no  
Collect TIR info:     no  
Block Incremental:    no  
Mult. Data Streams:   no  
Client Encrypt:       no  
Policy Priority:       0  
Max Jobs/Policy:      99  
Disaster Recovery:    0  
Residence:            myunit  
Volume Pool:          NetBackup  
Keyword:              (none specified)  
  
HW/OS/Client:  Linux          RedHat          zippity  
                SGI           IRIX6.5.15     mango
```

Include: /tmp/my

```
Schedule:          full
Type:              Full Backup
Frequency:         every 7 days
Maximum MPX:      1
Retention Level:  0 (1 week)
Residence:         (specific storage unit not required)
Volume Pool:       (same as policy volume pool)
Daily Windows:
  Sunday          00:00:00 --> Sunday    08:00:00
  Monday          00:00:00 --> Monday    08:00:00
  Tuesday         00:00:00 --> Tuesday   08:00:00
  Wednesday       00:00:00 --> Wednesday 08:00:00
  Thursday        00:00:00 --> Thursday  08:00:00
  Friday          00:00:00 --> Friday    08:00:00
  Saturday        00:00:00 --> Saturday  08:00:00
```

```
Schedule:          incr
Type:              Differential Incremental Backup
```

bppllist mypolicy_copy -U

```
-----
Policy Name:       mypolicy_copy
Policy Type:       Standard
Active:            yes
Client Compress:   no
Follow NFS Mounts: no
Cross Mount Points: no
Collect TIR info: no
Block Incremental: no
Mult. Data Streams: no
Client Encrypt:    no
Policy Priority:   0
Max Jobs/Policy:  99
Disaster Recovery: 0
Residence:         myunit
Volume Pool:       NetBackup
Keyword:           (none specified)
```

```
HW/OS/Client:    Linux          RedHat          zippity
                  SGI            IRIX6.5.15     mango
```

Include: /tmp/my

```
Schedule:          full
Type:              Full Backup
Frequency:         every 7 days
Maximum MPX:      1
Retention Level:  0 (1 week)
Residence:         (specific storage unit not required)
```

```

Volume Pool:      (same as policy volume pool)
Daily Windows:
  Sunday  00:00:00 --> Sunday    08:00:00
  Monday  00:00:00 --> Monday    08:00:00
  Tuesday 00:00:00 --> Tuesday   08:00:00
  Wednesday 00:00:00 --> Wednesday 08:00:00
  Thursday 00:00:00 --> Thursday  08:00:00
  Friday   00:00:00 --> Friday    08:00:00
  Saturday 00:00:00 --> Saturday  08:00:00

```

```

Schedule:      incr
Type:          Differential Incremental Backup

```

Example 3

Rename a policy from `policy_old` to `policy_new`. Before and after the renaming, `bppllist` shows the policies in the NetBackup configuration database:

```

bppllist
  mypolicy
  policy_old
  test
bppolicynew policy_old -renameto policy_new
bppllist
  mypolicy
  policy_new
  test

```

RETURN VALUES

An exit status of 0 means that the command ran successfully.

Any exit status other than 0 means that an error occurred.

If the administrative log function is enabled, the exit status is logged in the administrative daily log under the log directory:

```
install_path\NetBackup\logs\admin
```

It has the following form:

```
  bppolicynew: EXIT status = exit status
```

If an error occurred, a diagnostic precedes this message.

FILES

```

install_path\NetBackup\logs\admin\*
install_path\NetBackup\db\policy\policy_name

```

SEE ALSO

`bpplclients`, `bpplinfo`, `bpplsched`, `bppldelete`, `bppllist`

bpps

NAME

bpps - list all processes and statistics for each process

SYNOPSIS

```
install_path\NetBackup\bin\bpps [-l | -s | -S] [-t sample_time[m]] [-i |  
-x process_group] ... [host_name] ...
```

```
install_path\NetBackup\bin\bpps -? [process_group ...]
```

DESCRIPTION

The bpps command lists the process statistics for all processes that run on your system. This command enables you to list a specific process group. It also enables you specify a sample time in seconds (or milliseconds) before it lists the processes.

Note: The command options used by bpps are unrelated to the options used by the Unix bpps command.

OPTIONS

-?

Print the help screen. If you specify *process_group* here, it displays the list of processes that are included or excluded when you specify *process_group* with -i or -x options.

-l

Output a long listing.

-s

Output a short listing (default).

-S

Output a short listing without the header (for example, host name, date, and column headings).

-t *sample_time*[m]

Specify the sample time (default 1 second). The sample time is specified in seconds unless followed by m, which specifies the sample time in milliseconds.

-i process_group

Include the specified process group in the listing (default NB_ALL).

-x process_group

Exclude the specified process group from the listing.

host_name

The name of the host computer on which you list group process statistics.

NOTES

The following is a list of all of the valid process groups and a brief description of each.

MM_ALL

All Media Manager processes.

MM_CLIS

Media Manager command line programs.

MM_CORE

Media Manager core processes.

MM_GUI

Media Manager GUI programs.

MM_SERVICES

Media Manager services.

MM_UI

Media Manager user interface programs.

MM_WORKERS

Media Manager worker processes.

NB_ALL

All NetBackup, Media Manager ,and ARO processes.

NB_ALL_CLIS

All NetBackup and Media Manager command line programs.

NB_ALL_CORE

All NetBackup, Media Manager, and ARO core processes.

NB_ALL_GUI

All NetBackup and Media Manager GUI programs.

NB_ALL_SERVICES

All NetBackup and Media Manager Services.

NB_ALL_UI

All NetBackup and Media Manager user interface programs.

NB_ALL_WORKERS

All NetBackup and Media Manager worker processes.

NB_CLIENT_ALL

All NetBackup client processes.

NB_CLIENT_CLIS

NetBackup client command line programs.

NB_CLIENT_CORE

NetBackup client core processes.

NB_CLIENT_GUI

NetBackup client GUI programs.

NB_CLIENT_SERVICES

NetBackup client services.

NB_CLIENT_UI

NetBackup client user interface p

NB_CLIENT_WORKERS

NetBackup client worker processes.

NB_SERVER_ALL

All NetBackup server processes.

NB_SERVER_CLIS

NetBackup server command line programs.

NB_SERVER_CORE

NetBackup server core processes.

NB_SERVER_GUI

NetBackup server GUI programs.

NB_SERVER_SERVICES

NetBackup server services.

NB_SERVER_UI

NetBackup server user interface programs.

NB_SERVER_WORKERS

NetBackup server worker processes.

NBDE_SERVICES

NetBackup Database services.

NBDE_CLIS

NetBackup Database command line programs.

NBDE_ALL

All NetBackup Database processes.

VLT_CORE

Core Vault processes.

VLT_GUI

Vault GUI programs.

VLT_CLIS

Vault command line programs.

VLT_UIS

Vault user interface programs.

VLT_ALL

All Vault processes.

OTHER_PROCESSES

All processes not included in NB_ALL.

FILES

install_path\NetBackup\bin\bp.conf

bprecover

NAME

bprecover - recover selected NetBackup related catalogs

SYNOPSIS

```
install_path\NetBackup\bin\admincmd\bprecover
-l -m media_id -d density [-v]
-l -tpath raw_tape_device_path [-v]
-l -dpath disk_device_path [-v]
-l -opath optical_device_path [-v]
-l -5x -p policy_name [-v]
-l -vxss -p policy_name [-v]
-r [ALL | image_number [[-stdout] | [-dhost destination_host]]] -m
  media_id -d density [-v]
-r [ALL | image_number [[-stdout] | [-dhost destination_host]]] -tpath
  raw_tape_device_path [-v]
-r [ALL | image_number [[-stdout] | [-dhost destination_host]]] -dpath
  disk_device_path [-v]
-r [ALL | image_number [[-stdout] | [-dhost destination_host]]] -opath
  optical_device_path [-v]
-r [ALL | image_number] -5x -p policy_name [-v]
-r [ALL | image_number] -vxss -p policy_name [-v]
-r -nbdb [-v]
-wizard
```

Note: In an offline backup recovery, one or more of the NetBackup services must be in a stopped state before you use `bprecover`. Refer to the "Catalog Recovery From Offline Backup" section in the *NetBackup Troubleshooting Guide* for recovery procedures.

DESCRIPTION

The `bprecover` command initiates the NetBackup utility for restoring the NetBackup internal databases that are called catalogs. It recovers the catalogs

that were backed up by using the procedures, which are described in the *NetBackup Administrator's Guide*. Use `bprecover` only if catalogs were destroyed on disk.

The command has two main modes: `list` and `recover`. `list` shows the contents of a backup media or disk path. `recover` recovers the catalog files.

You must have administrator privileges to run this command.

OPTIONS

`-5x`

This parameter, when used with the `-p policy_name` option, defines a NetBackup 5.x media server. You must use this parameter with the `-p policy_name` option to recover an image from the following location.

```
install_path\NetBackup\db\NBU_5XMDB_IMAGE\catalog_backup_policy_name
```

`-l`

Lists the header information from the specified media or disk path.

`-m media_ID -d density`

Specifies the media ID and the density of the media from which to recover files. The Device Manager and Volume Manager services must be running when you use the `-m` option. When the `Volmgr\database` directory is restored, messages about busy files appear. You must reboot.

media_ID must be six or less characters and must be defined in the Enterprise Media Manager Database.

density must be one of the following:

4mm (4-mm cartridge)

8mm (8-mm cartridge)

d1t (dlt cartridge)

d1t2 (dlt cartridge alternate)

qscsi (1/4-inch cartridge)

Note that the following densities apply only to NetBackup Enterprise Servers.

hcart (1/2-inch cartridge)

hcart2 (1/2-inch cartridge alternate)

dtf (DTF cartridge)

`-nbdb`

Used with the `-r` option during catalog recovery procedures to recover and resynchronize the following databases: the NetBackup relational database, the EMM database, and the BMR database (if BMR is configured).

For complete catalog recovery procedures, see the catalog recovery procedures in the Disaster Recovery chapter of the *NetBackup Troubleshooting Guide*.

`-dpath disk_device_path`

`-tpath raw_tape_device_path`

`-opath optical_device_path`

Specifies a raw device path. If `-m` and `-d` are not specified. Use `-dpath`, `-opath`, or `-tpath` to specify a raw device path. Stop the NetBackup Device Manager and Volume Manager services when you use one of these options.

`-r [ALL | image_number]`

Recovers the images from the specified media or disk path. Three modes of recovery are available with `-r`:

If `-r ALL` is specified, recover all the images that are contained in the specified media or disk path.

If `-r image_number` is specified, recover only the selected image number from the specified media or disk path.

If only `-r` is specified, `bprecover` interactively prompts you to recover the images that are contained in the specified media or disk path.

`-r -nbdb`

If `-r -nbdb` is specified, recover and resynchronize the NetBackup relational database. Only used as part of catalog recovery procedures.

For complete catalog recovery procedures, see the catalog recovery procedures in the Disaster Recovery chapter of the *NetBackup Troubleshooting Guide*.

`-stdout`

Specifies that the selected backup image is written to stdout instead of automatically being restored. This option is useful if you lose only one file. You can restore it without restoring the rest of the catalog files in the image.

Note: You cannot specify `-r ALL` with `-stdout` because the `-stdout` option permits only one file image to be read at a time.

`-dhost destination_host`

Specifies the host to which the selected catalog is restored. Normally, catalogs are restored to the host where the data originated (as displayed with the `-l` option). The `-dhost` option makes it possible to restore the catalog to another host.

The NetBackup client or server software must be installed on the destination host and the NetBackup Client service must be running.

Caution: Use the `dhost` option with EXTREME caution, since it can overwrite existing catalogs on the destination host. To permit recovery in case you unintentionally overwrite the wrong catalogs, you can move existing catalogs to a temporary directory on the destination host.

Note: Do not specify `-r all` (or ALL) with `-dhost` when you use this command. Either explicitly specify an image (for example, `-r 2`) or use the interactive mode (`-r`).

`-v`

Selects the verbose mode. This option is meaningful only when you run with the debug log function on (that is, when the following directory is defined):

```
install_path\NetBackup\logs\admin
```

`-vxss`

When `-vxss` is used with the `-p policy_name` option, it enables you to recover the following: Symantec Product Authentication and Authorization Service data that was backed up by an online, hot catalog backup. The image is recovered from the following location:

```
install_path\NetBackup\db\NBU_VSSDB_IMAGE\policy_name
```

`-wizard`

This parameter enables a user to perform the same functions from a command line that are present on the recovery wizard. For example, a user can do the following.

- Specify the full pathname to the catalog disaster recovery file:
- Recover the entire NetBackup catalog

EXAMPLES

Example 1

List the backup header information for the catalog backup that was done to disk path `D:\apps\dbbackup`.

```
cd D:\VERITAS\NetBackup\bin\admincmd\  
bprecover -l -dpath D:\apps\dbbackup  
Database Backup Information from D:\apps\dbbackup
```

```
Created:      03/31/97 11:31:34  
Server:      bphost
```

```
Path  
----
```

```
IMAGE1 D:\VERITAS\NetBackup\db
```

```
IMAGE2 D:\VERITAS\Volmgr\database
```

Example 2

List the backup header information from media ID 000001, which is density dlt.

```
cd D:\VERITAS\NetBackup\bin\admincmd
bprecover -l -m 000001 -d dlt
Database Backup Information from 000001
```

```
Created:      03/31/97 05:50:51
Server:      bphost
Block size:  32768
```

```
Path
----
```

```
IMAGE1 D:\VERITAS\NetBackup\db
IMAGE2 D:\VERITAS\Volmgr\database
```

Example 3

Recover the D:\VERITAS\NetBackup\db files from disk path

D:\apps\dbbackup.

```
cd D:\VERITAS\NetBackup\bin\admincmd
bprecover -r 1 -dpath D:\apps\dbbackup
Recovering bphost:D:\VERITAS\NetBackup\db
```

Example 4

Recover all the backed up catalogs from media ID JBL29.

```
cd D:\VERITAS\NetBackup\bin\admincmd
bprecover -r ALL -m JBL29 -d 8mm
Recovering bphost:D:\VERITAS\NetBackup\db
Recovering bphost: D:\VERITAS\Volmgr\database
```

Example 5

Interactively restore selected images. Use raw tape path \\.\Tape1. Assume that the media that is loaded into the drive is the same one as in example 4.

```
cd D:\VERITAS\NetBackup\bin\admincmd
bprecover -r -tpath \\.\Tape1
Recover bphost: D:\VERITAS\NetBackup\db y/n (n)? n
Recover bphost: D:\VERITAS\Volmgr\database y/n (n)? y
Recovering bphost: D:\VERITAS\Volmgr\database
```

ERRORS

If errors occur during the recover operation, NetBackup writes error messages to the MS-DOS command window when you run the `bprecover` command.

FILES

```
install_path\NetBackup\logs\admin\*
install_path\NetBackup\db\*
```

```
install_path\Volmgr\database\*
```

SEE ALSO

`tpreq`

NetBackup Troubleshooting Guide for information on disaster recovery.

bprestore

NAME

bprestore - restore files from the NetBackup server

SYNOPSIS

```
install_path\NetBackup\bin\bprestore [-A | -B] [-drs] [-F file_options]
[-K] [-l | -H | -y] [-r] [-T] [-L progress_log [-en]] [-R rename_file]
[-C client] [-D client] [-S master_server] [-t policy_type] [-p
policy] [-s date] [-e date] [-w [hh:mm:ss]] [-k "keyword_phrase"] -f
listfile | filenames [-cm] [-drs] [-md] [-td temp_dir]
[-spsredir_server hostname] [-BR portal_name | teamsite_name] [copy
-x]
```

DESCRIPTION

bprestore lets users restore a backed up or archived file or list of files. You can also name directories to restore. If you include a directory name, bprestore restores all files and subdirectories of that directory. You can exclude a file or a directory path that was previously included in the restore by placing an exclamation mark (!) in front of the file or the directory path (does not apply to NDMP restores). For example, the exclude capability is useful if you want to exclude part of a directory from the restore.

Note: If a policy, schedule type, or date range is not specified, bprestore starts with the most recent full backup image. It includes all subsequent incremental and differential backup images. The most recent copy of a file is restored from these images.

By default, you are returned to the system prompt after bprestore is successfully submitted. The command works in the background and does not return completion status directly to you. The -w option lets you change this behavior so bprestore works in the foreground and then returns completion status after a specified time period.

The bprestore command restores the file from the most recent backups within the time period you specify, except for a true-image restore. (See the -T option description.)

bprestore overwrites any file of the same name that already exists on the local client disk, unless you include the -K option. You also can restore the files that

were backed up or archived on another client (-C option). To restore from other clients, the NetBackup administrator must validate you.

bprestore writes informative and error messages to a progress-log file if you do the following: create the file before you run the bprestore command and then specify the file with the -L *progress_log* option. If bprestore cannot restore the requested files or directories, you can use the progress log to find the reason for the failure.

For detailed troubleshooting information, create a directory that is named *install_path\NetBackup\logs\bprestore* with write access. bprestore then creates a debug log file in this directory.

The following restrictions apply to bprestore:

- You can restore the files and the directories that you own and those owned by other users if you have read access. You need write access to another user's directories and files to restore that user's files to their original location.
- The operating system restricts the number of files and directories that you can specify on a single bprestore command line. If this restriction is a problem, use the -f option to restore the files.

Use the bplist command to display information on the files and directories that were backed up or archived.

OPTIONS

-A | -B

Specifies whether to restore from archives (-A) or backups (-B). The default is -B.

-BR *portal_name* | *teamsite_name*

Specifies a portal name or the team site name to where the selected portal or team site is to be redirected in a SharePoint farm. A user should specify the redirected portal or team site as `http://portalname` | `http://teamsitename`, and should already exist in a farm.

-cm

Enables the restore operation to play through log files and roll back any uncompleted transactions. Use this option if your selection contains the last backup to be restored. If this option is not selected, the database is left in an intermediate state and is not yet usable.

-copy *x*

Specifies the copy number to restore from. The user is able to restore from a different copy than the primary copy. For example, -copy 3 restores copy 3 of a file or list of files.

Alternatively, you may specify the copy from which to restore at a global level (for all restore operations) by putting the copy number into the file `ALT_RESTORE_COPY_NUMBER`.

Refer to the “Restoring from a specific backup copy” section of the *NetBackup Backup, Archive, and Restore Getting Started Guide* for a complete description.

`-drs`

Restores the files without access-control attributes. By default, access-control attributes are restored along with file and directory data. Option `-drs` is available only to NetBackup administrators.

`-F file_options`

Allows either Backup Exec files to be restored, or both Backup Exec and NetBackup files to be restored. The default (`-F` is not specified), is to restore only NetBackup files.

To restore only Backup Exe files specify:

`-F 524288`

To restore Backup Exe and NetBackup files specify:

`-F 1048576`

`-K`

Causes `bprestore` to keep existing files rather than overwrite them when it restores files with the same name. The default is to overwrite existing files.

Note: The `-l` | `-H` | `-y` options apply only when you restore UNIX files to a UNIX system.

`-l` | `-H` | `-y`

Specify `-l` to rename the targets of UNIX links by using the `-R rename_file` option in the same way as when you rename files.

Specify `-H` to rename UNIX hard links by using the `-R rename_file` option in the same way as when you rename files. Soft links are unchanged.

Specify `-y` to rename UNIX soft links by using the `-R rename_file` option in the same way as when you rename files. Hard links are unchanged.

See Example 5 in the EXAMPLES section.

`-md`

Mounts the database so that it is available to users. This option is only available if Commit after restore completes is selected.

`-r`

Specify this option to restore disk images instead of file systems.

-L *progress_log* [-en]

Specifies the name of an existing file in which to write progress information.

For example: `c:\proglog`

The default is not to use a progress log.

Include the `-en` option to generate a log in English. The name of the log contains the string `_en`. This option is useful to support any personnel that assist in a distributed environment where different locales may create logs of various languages.

-R *rename_file*

Specifies the name of a file with name changes for alternate-path restores.

For example: `bprestore -R /C/renamefile /C/origfile`

Where `/C/rename_file` is the file with the name change and `/C/origfile` is the file to be renamed.

Use the following form for entries in the rename file:

`change backup_filepath to restore_filepath`

The file paths must start with `/` (slash)

The first *backup_filepath* that is matched is replaced with the *restore_filepath* string.

Use all upper case for the drive letter.

The default is to restore by using the original path.

For example, the following entry renames `C:\users\fred` to `C:\users\fred2`:

`change /C/users/fred to /C/users/fred2`

(Be sure to end the entry with a return).

When you restore to a Windows client, you can also use the following method for specifying entries in the rename file:

(Do not use this method for other clients.)

`rename bulength backup_filepath reslength restore_filepath`

Where:

bulength is the number of ASCII characters in the backup path.

reslength is the number of ASCII characters in the restore path.

The first *backup_filepath* that is matched is replaced with the *restore_filepath* string.

For example, the following entry renames `C:\fred.txt` to `C:\fred2.txt`:

`rename 11 /C/fred.txt 12 /C/fred2.txt`

(Be sure to end the entry with a return.)

-C client

Specifies a client name to use for finding backups or archives from which to restore files. This name must be as it appears in the NetBackup catalog. The default is the current client name.

Note: The destination client does not default to the source client. See the description for *-D client* option.

-D client

Specifies a destination client. The default is the current client name.

The master server administrator can use this option to direct restored files to a machine other than the client that the *-C* option specifies.

-S master_server

Specifies the name of the NetBackup server. The default is the server designated as current on the Servers tab of the **Specify NetBackup Machines** dialog. To display this dialog box, start the Backup, Archive, and Restore user interface on the client. Then click **Specify NetBackup Machines** on the File menu.

-spsredir_server hostname

This option specifies the Web server on which the redirected portal or team site resides in a SharePoint farm. The redirected Web server should be specified as *hostname*.

-t policy_type

Specifies one of the following numbers that corresponds to the policy type. The default is 0 for all clients except Windows, where the default is 13.

0 = Standard

4 = Oracle

6 = Informix-On-BAR

7 = Sybase

8 = MS-SharePoint

10 = NetWare

13 = MS-Windows

14 = OS/2

15 = MS-SQL-Server

16 = MS-Exchange-Server

19 = NDMP

Note that the following policy types apply only to NetBackup Enterprise Server:

11 = DataTools-SQL-BackTrack

17 = SAP

18 = DB2

20 = FlashBackup

21 = Split-Mirror

22 = AFS

35 = NBU-Catalog

`-p policy`

Specifies the policy for which the backups or archives were performed.

`-s date`

`-e date`

Specifies the start and the end date range for the listing. The `bprestore` command restores only files from backups or the archives that occurred within the specified start and end date range.

`-s` specifies a start date and time for the restore window. `bprestore` restores files only from the backups or the archives that occurred at or after the specified date and time.

The valid range of dates is from 01/01/1970 00:00:00 to 01/19/2038 03:14:07. The default start date is 01/01/1970 00:00:00.

The default is to return the most recent image. For backups, this image is the most recent full backup if a full backup exists. If a full backup does not exist, then the most recent incremental or user-directed backup is restored.

`-e` specifies an end date and time for the restore window. `bprestore` restores only files in the backups or the archives that occurred at or before the specified date and time. Use the same format as for the start date and time.

The end backup date and time do not need to be exact, except for a true-image restore (see the `-T` option description). `bprestore` restores the file that has the specified backup date and time. Or it restores the file that precedes the end date and time, which is most recent backup. The default is the current date and time.

`-td temp_dir`

This option provides a location where the associated log and any patch files are to be kept until the database is restored. If storage groups are restored, a subdirectory in `temp_dir` is created for each storage group. The log and patch files for each storage group are kept in the corresponding subdirectory.

The default location is C:\temp.

`-T`

Specifies a true-image restore, where only the files and the directories that existed in the last true-image backup are restored. This option is useful only if true-image backups were performed. If this option is not specified, all files and directories that meet the specified criteria are restored, even if they were deleted.

When the `-T` option is specified, the image that is requested must be uniquely identified. Unique identification is accomplished by using the `-e` option with seconds granularity. The `-s` option (if any) is ignored. The seconds granularity of an image can be retrieved by using the `bplist` command with the `-l` and `-Listseconds` options.

`-w [hh:mm:ss]`

Causes NetBackup to wait for a completion status from the server before returning you to the system prompt.

You can optionally specify a wait time in hours, minutes, and seconds. The maximum wait time you can specify is 23:59:59. If the wait time expires before the restore is complete, the command exits with a timeout status. The restore, however, still completes on the server.

If you specify 0 or do not specify a time, the wait time is indefinite for the completion status.

`-k "keyword_phrase"`

Specifies a keyword phrase for NetBackup to use when it searches for backups or archives from which to restore files. The phrase must match the one that was previously associated with backup or archive by the `-k` option of the `bbackup` or the `barchive` command.

Use this option in place of or in combination with the other restore options to make it easier to restore your backups and archives. The following meta characters can simplify the match of keywords or parts of keywords in the phrase:

* matches any string of characters.

? matches any single character.

[] matches one of the sequence of characters that is specified within the brackets.

[-] matches one of the range of characters that the "-" separates.

The keyword phrase can be up to 128 characters in length. All printable characters are permitted including space (" ") and period (".").

The phrase must be enclosed in double quotes ("...") or single quotes ('...').

The default keyword phrase is the null (empty) string.

`-f listfile`

Specifies a file (*listfile*) that contains a list of files to be restored and can be used instead of the *filenames* option. In *listfile*, list each file path on a separate line.

The required format for the file list depends on whether the files have spaces or newlines in the names.

To restore the files that do not have spaces or new lines in the names, use this format:

filepath

Where *filepath* is the path to the file that you restore. For example:

Note: Use upper case for the drive letter. For example,
C:\NetBackup\Log1.

C:\programs

C:\winnt

C:\documents\old_memos

To restore the files that have spaces or new lines in the names, use one of the following formats:

filepathlen filepath

filepathlen filepath start_date_time end_date_time

filepathlen filepath -s datetime -e datetime

The *filepath* is the path to the file you restore.

The *filepathlen* is the total number of characters in the file path.

The *start_date_time* and *end_date_time* are the decimal number of seconds since 01/01/1970 00:00:00.

datetime is the same as the command line (*mm/dd/yy [hh[:mm[:ss]]]*). The command uses the start date, end date, and time from the command line unless a line in *listfile* overrides it. The dates may change from line to line.

To exclude a file or a directory path that was previously included in the restore, place an exclamation mark (!) in front of the file or the directory path. (Exception: NDMP restores)

The following is an example that uses *filepathlen filepath*:

11 C:\programs

8 C:\winnt

22 C:\documents\old memos

17 !C:\programs\test

filenames

Names one or more files to be restored and can be used instead of the `-f` option.

Any files that you specify must be listed at the end, following all other options. You must also specify absolute file paths. To exclude a file or a directory path that was previously included in the restore, place an exclamation mark (!) in front of the file or the directory pat. (Exception: NDMP restores.)

Use upper case for the drive letter. For example, `C:\NetBackup\log1`.

EXAMPLES

Example 1

Restore files from backups of `file1` that were performed between 04/01/2006 06:00:00 and 04/10/2006 18:00:00. Enter the following:

(Enter all on one line.)

```
bprestore -s 04/01/06 06:00:00 -e 04/10/06 18:00:00 C:\user1\file1
```

Example 2

To restore the files that are listed in a file named `restore_list` by using the most recent backups, enter the following:

```
bprestore -f c:\restore_list
```

Example 3

Restore directory `C:\kwc` from the backups that are associated with a keyword phrase that contains "My Home Directory". Use a progress log named `d:\kwc\bkup.log`.

Enter the following (on one line):

```
bprestore -k "*My Home Directory*" -L d:\kwc\bkup.log C:\kwc
```

Example 4

Restore the D drive on the Windows client `slater` from the backups that are associated with a keyword phrase that contains "My Home Dir".

Use a progress log named `c:\kwc\bkup.log`.

Enter the following:

(Enter all on one line or use the backslash continuation character.)

```
bprestore -k "*My Home Dir*" -C slater -D slater -t 13 -L  
c:\kwc\bkup.log D:\
```

Example 5

Assume you have a rename file named `/home/kwc/rename` on a UNIX client and it contains the following:

```
change /home/kwc/linkback to /home/kwc/linkback_alt
```

To restore the hard link that is named `/home/kwc/linkback` to alternate path `/home/kwc/linkback_alt` on that client, run the following command:

```
bprestore -H -R /home/kwc/ rename /home/kwc/linkback
```

Example 6

Assume you want to restore files from backups of the file `C:\user1\`.

The backups were performed between `04/01/06 06:00:00` and `04/10/06 18:00:00`.

You also want to exclude all files with a `.pdf` extension, except for the file named `final_doc.pdf`. To perform this operation, run the following (on one line):

```
bprestore -s 04/01/06 06:00:00 -e 04/10/06 18:00:00  
C:\user1\ !C:\user1\*.pdf C:\user1\final_doc.pdf
```

FILES

```
install_path\NetBackup\logs\bprestore\*.log
```

SEE ALSO

`bp`, `bparchive`, `bpbackup`, `bplist`

bpschedule

NAME

bpschedule - add, delete, or list disk staging storage unit (DSSU) schedules

SYNOPSIS

```

install_path\NetBackup\bin\admincmd\bpschedule [-v] [-M
  master_server,...] -add sched_label [-freq frequency] [-stage_priority
  number] [-altreadhost hostname] [-number_copies number] [-residence
  storage_unit_label [,stunit-copy2,...]] [-pool volume_pool_label
  [,pool-copy2,...]] [-fail_on_error 0|1[,0|1,...0|1] [-window
  start_duration]] [-cal 0|1|2] [-ut] [-incl mm/dd/yyyy] [-excl
  mm/dd/yyyy] [-weekday day_name_week] [-dayomonth 1-31 | 1]

install_path\NetBackup\bin\admincmd\bpschedule [-v] [-M
  master_server,...] -delete sched_label ...

install_path\NetBackup\bin\admincmd\bpschedule [-v] [-M
  master_server,...] -deleteall

install_path\NetBackup\bin\admincmd\bpschedule [-v] [-M master_server...]
  [-L | -l | -U] [-label sched_label]

```

DESCRIPTION

The `bpschedule` command does one of the following:

- Add a new disk staging storage unit (DSSU) schedule.
- Delete one or more DSSU schedules.
- Delete all the DSSU schedules.
- List one or all DSSU schedules.
- The default is to list all DSSU schedules.

For the `-add` and `-delete` options, `bpschedule` returns to the system prompt immediately after it submits the DSSU schedule change request to NetBackup. To determine whether the change was successful, run `bpschedule` again to list the updated schedule information.

When the listing option is used, a single entry for each schedule appears, even if the `-M` option is used. The `-l` form lists the information for each schedule on several lines. `-l` does not identify the attributes by name; these are as follows (where the names are not described, they are reserved for internal NetBackup use):

Line 1: SCHED, schedule name, type, max_mpx, frequency, retention level, u_wind/o/d, 2 internal attributes, maximum fragment size, calendar, number of copies, and fail on error. Note that u_wind/o/d is a field reserved for future use. The u_wind entry in the -L display is also reserved for future use.

Line 2: SCHEDWIN, seven pairs of the form start , duration, expresses the start and duration of the window for each day of the week. The week starts with Sunday.

Line 3: SCHEDRES, residence (a value for each copy).

Line 4: SCHEDPOOL, pool (a value for each copy).

Line 5: SCHEDRL, retention level (a value for each copy).

Line 6: SCHEDFOE, fail on error (a value for each copy).

If the -M option is used, bpschedule performs the operation on each of the listed master servers. For instance, if bpschedule adds a schedule, bpschedule adds the schedule to the policy on each of the listed master servers for -M. If -M is used on a listing request, the listing is composed of the returned information from all the master servers in the -M list. If the command fails for any of the master servers, activity stops at that point.

To modify an existing NetBackup schedule, use the NetBackup command bpschedulerep.

Any authorized user can initiate this command.

For more information about NetBackup authorization, refer to the *NetBackup Security and Encryption Guide*.

OPTIONS

These options are common to all forms of bpschedule:

-help

Prints a command line usage message when -help is the only option on the command line.

-M master_server, . . .

A list of alternative master servers. This list is a comma-separated list of host names. If this option is present, each master server in the list runs the bpschedule command. Each master server in the list must allow access by the system that issues the bpschedule command.

If this option is present, the command is run on each master server in the list. If an error occurs for any master server, the process terminates at that point.

If bpschedule produces a listing, the listing is the composite of the returned information from all the master servers in this list.

If `bpschedule` adds or deletes a schedule, all master servers in this list receive the change.

`-v`

Selects verbose the mode. This option causes `bpschedule` to log additional information for debugging purposes. The information goes into the NetBackup administration debug log. This option is meaningful only when NetBackup enables the debug log function (that is, when the following directory is defined):

```
install_path\NetBackup\logs\admin
```

The remaining options depend on the form of `bpschedule`. The first form of `bpschedule` adds a schedule to the specified storage unit name. The following options apply to this form of `bpschedule`:

`-add sched_label [suboptions]`

Add a single schedule to the specified storage unit name.

The following describes the suboptions for the `-add` option. These are attributes of the schedule being added.

Refer to the *NetBackup Administrator's Guide* for details on schedules and their attributes.

`-cal 0|1|2`

Indicates whether `bpschedule` follows a calendar-based schedule or a frequency-based schedule.

0 = frequency-based schedule

1 = calendar-based schedule with no retries after run day

2 = calendar-based schedule with retries after run day

`-dayomonth 1-31 | 1`

Specifies the day of every month to run the schedule. Enter `l` (lowercase L) to run the last day of every month, whether the month contains 28, 29, 30, or 31 days.

For example, to run the schedule the 15th day of every month, enter:

```
-dayomonth 15
```

To run the last day of every month, enter:

```
-dayomonth l
```

`-excl mm/dd/yyyy`

Indicates to exclude this single date.

`-fail_on_error 0|1[,0|1,...,0|1]`

Specifies whether to fail all other copies if one copy fails. If no parameter is specified, 0 is default for all copies. Specify a value for each copy.

0 = Do not fail the other copies

1 = Fail other copies

`-freq frequency`

Determines how often backups run. Represents the number of seconds between the backups that are initiated according to this schedule. Valid range for this option is 0 through 2419200 (number of seconds in four weeks). When this value is omitted on the command line, the default value is 604800 (duration of one week in seconds).

`-incl mm/dd/yyyy`

Indicates to include this single date.

`-number_copies number`

Specify the number of simultaneous backup copies. The minimum value is 1. The maximum value is 4 or the Maximum Backup Copies global parameter, whichever is smaller. The default is 1.

`-pool volume_pool_label[,pool-copy2,... pool-copyn]`

The name of the volume pool. This choice overrides the policy-level volume pool. The value `"*NULL*"` causes NetBackup to use the volume pool that is specified at the policy level. The default is to use the volume pool that is specified at the policy level. The volume pool label cannot be None. If you do not specify a volume pool at either the schedule level or the policy level, NetBackup uses a default value of NetBackup.

When you specify `-number_copies` greater than 1, specify a pool for each copy.

`-residence storage_unit_label [,stunit-copy2,...]`

The name of the storage unit, which specifies the location of the backup images. The value `"*NULL*"` causes NetBackup to use the storage unit that is specified at the policy level. The default is for NetBackup to use the storage unit that is specified at the policy level. If you do not specify a storage unit at either the schedule level or the policy level, NetBackup uses the next storage unit available.

When you specify `-number_copies` greater than 1, specify a residence for each copy.

`-stage priority number`

The order in which storage units are to be selected within a storage unit group:

1 = Use the storage units in the order that appears in the storage unit group dialog box (default).

2 = Use the storage unit least recently used. (The storage units take turns.)

3 = Use the first storage unit in the list that is not full or down. If the storage unit is only busy, the policy waits to write to it.

`-altreadhost hostname`

The server to be used to read a backup image that a different media server originally wrote.

`-ut`

If any of the date or the time arguments follow `-ut`, they are accepted as UNIX time, instead of the standard time format. The `-ut` option is used primarily for Java.

`-weekday day_name week`

Specifies a day of the week, and the week of the month, as a run day in the schedule.

The *day_name* is: Sunday, Monday, Tuesday, Wednesday, Thursday, Friday, or Saturday.

The *week* is the number of the week in the month.

For example, to instruct the policy to run the second Monday of the month, enter:

`-weekday Monday 2`

`-window start_duration`

Specifies when NetBackup can run the backups for this schedule. Every day of the week has the same window.

start is the time at which the backup window opens for this schedule. This number is the number of seconds since midnight. This number is an integer between 0 and 86399 (86400 seconds in a day).

duration is the length of time that the window remains open. The time unit is seconds. This number is a non-negative integer.

The second form of `bpschedule` deletes one or more schedules from the named policy. The following option applies to this form of `bpschedule`:

`-delete sched_label`

Delete the listed schedules from the named policy. Separate the elements of the *sched_label* list with spaces. There can be up to 25 labels in the list.

The third form of `bpschedule` deletes all schedule from the named policy. The following option applies to this form of `bpschedule`:

`-deleteall`

Delete all schedules from the named policy.

The fourth form of `bpschedule` produces a listing of information about the schedules for the named policy. The following options apply to this form of `bpschedule`:

-l

The list type is short. This list is the default list type. This option produces a terse listing that includes all attributes for the schedule. Each schedule occupies one line of the listing. Most attribute values are expressed numerically. This option is useful for scripts or the programs that rework the listing contents into a customized report format.

-L

The list type is long. This listing includes all attributes for the schedule. Some attribute values are descriptive terms, rather than numbers.

-label *sched_label*

List the attributes for this schedule in the named policy. The default is to list information for all schedules for the named policy.

-U

The list type is user. This listing is similar to the long-type list, but it has fewer entries. Most attribute values are descriptive terms, rather than numbers.

EXAMPLES

In this example, `bpschedule` lists the information for schedule `test` in Long mode.

```
bpschedule -L -label test
Schedule:          test
Type:              FULL (0)
Frequency: 7day(s) (604800 seconds)
Retention Level: 1(2 weeks)
u-wind/o/d:       0 0
Incr Type:        DELTA (0)
Incr Depends: (none defined)
Max Frag Size:0 MB (1048576 MB)
Maximum MPX: 1
Number copies:1
Fail on Error:0
Residence:        (specific storage unit not required)
Volume Pool:      (same as policy volume pool)
Daily Windows:
Day              Open          Close          W-Open        W-Close
Sunday          000:00:00  000:00:00
Monday          000:00:00  000:00:00
Tuesday         000:00:00  000:00:00
Wednesday       000:00:00  000:00:00
Thursday        000:00:00  000:00:00
Friday          000:00:00  000:00:00
Saturday        000:00:00  000:00:00
```

FILES

*install_path\NetBackup\logs\admin**
install_path\NetBackup\db\sched\schedule name

SEE ALSO

bpschedulerep

bpschedulerep

NAME

bpschedulerep - modify attributes of disk staging storage unit (DSSU) schedule

SYNOPSIS

```
install_path\NetBackup\bin\admincmd\bpschedulerep sched_label [ -M  
master_server,...] [-v] [-freq backup_frequency] [-stage_priority  
number] [-altreadhost hostname] [-cal 0|1|2] [-incl mm/dd/yyyy] [-excl  
mm/dd/yyyy] [-delincl mm/dd/yyyy] [-delexcl mm/dd/yyyy] [-weekday  
day_name week] [-dayomonth 1-31 | 1] [-delweekday day_name week]  
[-deldayomonth 1-31 | 1] [-ci] [-ce] [-cw] [-cd] [-number_copies  
number] [-fail_on_error 0|1[,0|1,...,0|1]] [-residence  
storage_unit_label [,stunit-copy2,...]] [-pool volume_pool_label  
[,pool-copy2,...]] [-(0..6) start duration]
```

DESCRIPTION

bpschedulerep changes the attributes of a NetBackup disk staging storage unit (DSSU) schedule. The schedule that bpschedulerep named should already exist when this command is run. bpschedulerep changes the schedule on each of the master servers that are listed, if the -M option is used.

Any authorized user can initiate this command.

For more information about NetBackup authorization, refer to the *NetBackup Security and Encryption Guide*.

OPTIONS

-(0..6) *start duration*

Specifies the window during which NetBackup can run the backups for this schedule. This window applies to a specific day of the week. 0 corresponds to Sunday, 1 to Monday, and so on.

start is the time at which the backup window opens for this schedule. This number is the number of seconds since midnight. It is an integer between 0 and 86400 (the number of seconds in a day).

duration is the length of time that the window remains open. The time unit is seconds. It is a non-negative integer.

-cal 0|1|2

Indicates whether bpschedulerep follows a calendar-based schedule or a frequency-based schedule.

0 = frequency-based schedule

1 = calendar-based schedule with no retries after run day

2 = calendar-based schedule with retries after run day

`-dayomonth 1-31 | 1`

Specifies the day of every month to run the schedule. Enter l (lowercase L) to run the last day of every month, whether the month contains 28, 29, 30, or 31 days.

For example, to run the schedule the 15th day of every month, enter:

`-dayomonth 15`

To run the last day of every month, enter:

`-dayomonth l`

`-deldayomonth 1-31 | 1`

Specifies a day of every month to be excluded as a run day. Enter l (lowercase L) to exclude the last day of every month, whether the month contains 28, 29, 30, or 31 days.

For example, to exclude the 10th day of every month from the schedule, enter:

`-deldayomonth 20`

`-delweekday day_name week`

Specifies a day of the week and the week of the month to be excluded as a run day from the schedule.

The *day_name* is: Sunday, Monday, Tuesday, Wednesday, Thursday, Friday, or Saturday.

The *week* is the number of the week in the month.

For example, to exclude the second Monday of the month, enter:

`-delweekday Monday 2`

`-excl mm/dd/yyyy`

Indicates to exclude this single date.

`-delincl mm/dd/yyyy`

Indicates to delete this single date.

`-delexcl mm/dd/yyyy`

Indicates to delete this single date.

`-ci`

Clears all specific include dates.

`-ce`

Clears all specific exclude dates.

-cw

Clears all week days.

-cd

Clears all days of a month.

-fail_on_error 0|1[,0|1,...,0|1]

Specifies whether to fail all other copies if one copy fails. If no parameter is specified, 0 is default for all copies. Specify a value for each copy.

0 = Do not fail the other copies

1 = Fail other copies

-freq *backup_frequency*

The backup frequency controls how much time can elapse between successful automatic backups for clients on this schedule. Frequency does not apply to user schedules because the user can perform a backup or archive any time the backup window is open. This value is a positive integer that represents the number of seconds between successful automatic backups for this schedule.

-help

Prints a command line usage message.

-incl *mm/dd/yyyy*

Indicates to include this single date.

-M *master_server,...*

A list of alternative master servers. This list is a comma-separated list of hostnames. If this option is present, each master server in the list runs the `bpschedulerep` command. Each master server in the list must allow access by the system that issued the `bpschedulerep` command. If an error occurs for any master server, the process terminates at that point.

The schedule attributes are modified on all the master servers in this list.

-number_copies *number*

Specify the number of simultaneous backup copies. The minimum value is 1. The maximum value is 4 or the Maximum Backup Copies global parameter, whichever is smaller. The default is 1.

-pool *volume_pool_label[,pool-copy2,... pool-copyn]*

Specifies the volume pool(s) for the schedule. Do not use this option if a disk storage unit is the residence for the schedule. If `**NULL**` is specified, the volume pool for the schedule is the volume pool of the policy that contains this schedule.

Specify a pool for each copy.

To display the configured volume pools, run the following command:

```
install_path\Volmgr\bin\vmppool -listall
```

`-residence storage_unit_label[,stunit-copy2,... stunit-copyn]`

Specifies the label(s) of the storage unit to be used for storing the backups that were created according to this schedule. If `"*NULL*"` is specified, the residence for the schedule defaults to the residence of the policy that contains this schedule. If the residence value is a storage unit label, the residence for the schedule becomes that storage unit; it overrides the residence for the policy.

Specify a storage unit for each copy.

Run `bpstulist` to display the set of defined storage units.

`-stage priority number`

The order in which storage units are to be selected within a storage unit group:

1 = Use the storage units in the order that appears in the storage unit group dialog box (default).

2 = Use the storage unit least recently used. (The storage units take turns.)

3 = Use the first storage unit in the list that is not full or down. If the storage unit is only busy, the policy waits to write to it.

`-altreadhost hostname`

The server to be used to read a backup image that a different media server originally wrote.

`sched_label`

The name of the schedule to be changed. This schedule has been previously created.

`-weekday day_name week`

Specifies a day of the week, and the week of the month, as a run day in the schedule.

The `day_name` is: Sunday, Monday, Tuesday, Wednesday, Thursday, Friday, or Saturday.

The `week` is the number of the week in the month.

For example, to instruct the policy to run the second Monday of the month, enter:

`-weekday Monday 2`

`-v`

Selects the verbose mode. This option causes `bpschedulerep` to log additional information for debugging purposes. The information goes into the NetBackup administration daily debug log. This option is meaningful only when NetBackup enables the debug log function (that is, when the following directory is defined):

`install_path\NetBackup\logs\admin`

EXAMPLES

Example 1

Change and schedule named test.

```
bpschedulerep test -cal 2
```

The following output is received after the change and a "bpschedule -label test" listing.

```
SCHED test 0 1 604800 1 0 0 0 *NULL* 0 2 0 0 0
SCHEDWIN 0 0 0 0 0 0 0 0 0 0 0 0 0
SCHEDRES *NULL* *NULL* *NULL* *NULL* *NULL* *NULL* *NULL* *NULL*
*NULL* *NULL*
SCHEDPOOL *NULL* *NULL* *NULL* *NULL* *NULL* *NULL* *NULL* *NULL*
*NULL* *NULL*
SCHEDRL 1 1 1 1 1 1 1 1 1 1
SCHEDFOE 0 0 0 0 0 0 0 0 0 0
```

Example 2

For Saturday and Sunday of each week, have the window for schedule test open at 10 pm instead of 11 pm. Also, have the window duration be 2 hours instead of 1 hour. bpschedulerep resets the windows, and bpschedule lists the new schedule values.

```
bpschedulerep test -0 79200 7200 -6 79200 7200
```

```
bpschedule -U -label test
```

```
Schedule:          test
  Type:            Full Backup
  Frequency:       every 7 days
  Retention Level: 1 (2 weeks)
  Maximum MPX:    1
  Residence:       (specific storage unit not required)
  Volume Pool:    (same as policy volume pool)
  Daily Windows:
    Sunday    22:00:00 --> Sunday    24:00:00
    Monday    23:00:00 --> Monday    24:00:00
    Tuesday   23:00:00 --> Tuesday   24:00:00
    Wednesday 23:00:00 --> Wednesday 24:00:00
    Thursday  23:00:00 --> Thursday  24:00:00
    Friday    23:00:00 --> Friday    24:00:00
    Saturday  22:00:00 --> Saturday  24:00:00
```

FILES

```
install_path\NetBackup\logs\admin\*
install_path\NetBackup\db\sched\schedule name
```

SEE ALSO

bpschedule

bpsetconfig

NAME

`bpsetconfig` - update a NetBackup configuration

SYNOPSIS

```
install_path\NetBackup\bin\admincmd\bpsetconfig[-h host] [-u user] [file ...]
```

```
install_path\NetBackup\bin\admincmd\bpsetconfig-H
```

DESCRIPTION

The `bpsetconfig` command is used as a stand-alone program, or as a helper program with the `backuptrace` and the `restoretrace` commands, to update a configuration. This command is available for all NetBackup server platforms.

You must have administrator privileges to run this command.

OPTIONS

`-h host`

Specifies the host name (*host*) of the server or client whose configuration is updated.

`-u user`

Specifies the user (*user*) whose configuration is updated.

`file...`

Specifies the file or files where the updates are listed. If not specified, standard input is read.

`-H`

Displays the help screen.

EXAMPLE

The following example demonstrates how to set a NetBackup configuration on a different system.

```
bpsetconfig -h orange.colors.org
SERVER = yellow.colors.org
SERVER = orange.colors.org
<ctl-Z>
```

Sets the NetBackup configuration on the system `orange.colors.org` to the designated server that follows. This means that `yellow.colors.org` is the master server for the client `orange.colors.org`:

```
SERVER = yellow.colors.org
```

```
SERVER = orange.colors.org
```

bpstsinfo

NAME

bpstsinfo - display information on storage servers, LSUs, images, and plugins

SYNOPSIS

```
install_path\NetBackup\bin\admincmd\bpstsinfo -serverinfo | -si
    [-servername | -sn server_name] [-serverprefix server_prefix] [-remote
    remote_server,...]

install_path\NetBackup\bin\admincmd\bpstsinfo -lsuinfo | -li [-servername
    | -sn server_name] [-serverprefix server_prefix] [-lsuname
    lsu_name,...] [-filteronimagemodetype [ STS_SA_IMAGE | STS_SA_OPAQUEF
    | STS_SA_CLEARF] [-remote remote_server,...]

install_path\NetBackup\bin\admincmd\bpstsinfo -imageinfo | -ii
    [-servername | -sn server_name] [-serverprefix server_prefix]
    [-lsuname lsu_name,...] [-imagename image_name] [-imagedate
    image_date] [[-imagedatestart image_date] [-imagedateend image date]]
    [-imagetype STS_FULL_ONLY | STS_INCR_ONLY] [-remote remote_server,...]

install_path\NetBackup\bin\admincmd\bpstsinfo -diskspaceinfo | -dsi
    -stype name SnapVault | AdvancedDisk | SharedDisk

install_path\NetBackup\bin\admincmd\bpstsinfo -plugininfo | -pi
    [-serverprefix server_prefix] [-stype server_type]

install_path\NetBackup\bin\admincmd\bpstsinfo -imagegroupelist | -igl
    [-servername | -sn server_name] [-serverprefix server_prefix]
    [-lsuname lsu_name,...] [-imagename image_name] [[-imagedatestart
    image_date] [-imagedateend image date]] [-imagetype STS_FULL_ONLY |
    STS_INCR_ONLY ] [-remote remote_server,...]

install_path\NetBackup\bin\admincmd\bpstsinfo -comparedbandstu | -cdas
    -servername | -sn server_name | -storage_server storage_server
    -serverprefix server_prefix | -stype server_type [-lsuname
    lsu_name],... -oldservervolume old_sts_server:old_volume
    [-oldservervolume old_sts_server:old_volume ...] [-remote
    remote_server,...]

install_path\NetBackup\bin\admincmd\bpstsinfo -deleteimage | -di
    -servername | -sn server_name -serverprefix server_prefix -lsuname
    lsu_name -imagename image_name -imagedate image_date [-remote
    remote_server,...]
```

DESCRIPTION

The `bpstsinfo` command displays the attributes for plugins, storage servers, logical storage units (LSUs), and the images that reside on disk. The command also compares images old and current servers and volumes, displays all image IDs for an image group, and deletes a specified image. A log of the command activity is sent to the NetBackup admin log file for the current day. All errors for this command go to `stderr`.

Only authorized users can run this command.

For more information about NetBackup authorization, refer to the *NetBackup Security and Encryption Guide*.

OPTIONS

Only one of the following options can be specified on a single command line.

`-serverinfo | -si`

Prints the storage server information.

`-lsuinfo | -li`

Prints the LSU information.

`-imageinfo | -ii`

Prints the image information.

`-diskspaceinfo | -dsi`

Prints the aggregated space for a specified disk type.

`-plugininfo | -pi`

Prints the plugin information for internal and external plugins on the system. When you use `-plugininfo` with no sub-options, all plugins are printed. Use with `-serverprefix` to restrict the printout to only the plugin with the specified prefix. Use `-stype` to restrict the printout to only plugins of the specified storage server type.

`-imagegroupelist | -igl`

For a given image and image group type, print all associate image IDs

`-comparedbandstu | -cdas`

Compares image information in the catalog to image information on the storage server physical media. The storage server previous OpenStorage servers and volumes to a current OpenStorage server and volume. This option requires `-servername`, `-serverprefix`, `-lsuname`, `-oldservervolume` arguments.

`-deleteimage | -di`

Deletes the specified image. This option requires `-servername`, `-serverprefix`, `-lsuname`, `-imagename`, and `-imagedate` arguments.

SUB-OPTIONS

`-stype SnapVault | AdvancedDisk | SharedDisk`

Specifies the disk type used with the `-diskspaceinfo` option to display the aggregated space. An example of the output display:

```
Disktype: SharedDisk TotalCapacity: 100000000 TotalUsed:
10000000
```

Licensing is based on the TotalCapacity and TotalUsed values.

`-filteronimagemodetype [STS_SA_IMAGE | STS_SA_OPAQUEF | STS_SA_CLEARF]`

Limits the LSUs to be printed on the system to the specified image mode type.

`-imagedate image_date`

Specifies a single image.

Acceptable formats:

```
03/08/2007 09:41:22
```

```
1110296416
```

This option can be used with `-imageinfo` only; it cannot be used with `-imagedatestart` or `-imagedateend`.

`-imagedateend image_date`

Optional filter argument. By default, all images are used. Specify `MM/DD/YYYY HH:MM:SS` to the images to something that is equal to or newer than the *image_date*.

`-imagedatestart image_date`

Optional filter argument. By default, all images are used. Specify `MM/DD/YYYY HH:MM:SS` to limit the images to something that is equal to or newer than the *image_date*.

`-imagegroupstype STS_IGT_SNAP | STS_IGT_REUSE`

`-imagename image_name`

Optional filter argument. By default, all images are used. Specify *image_name* to limit to only the images that match.

`-imagetype STS_FULL_ONLY | STS_INCR_ONLY`

Optional filter argument. By default, both the full and the incremental images are used. `STS_FULL_ONLY` or `STS_INCR_ONLY` to limit to only images from a full backup or an incremental backup.

`-lsuname lsu_name,...`

Optional filter argument. By default, all LSUs are used. Specify *lsu_name* to limit to one LSU for each `-lsuname` supplied.

- `-remote remote_server [-remote remote_server ...]`
 Specifies the name of a remote server to query for disk information. Multiple remote servers can be specified, one for each `-remote` supplied.
- `-servername server_name`
 Specifies the hostname of the STS server. If `-servername` is not specified, the hostname of the local host is used.
- `-serverprefix server_prefix`
 Limit server prefixes to the one that is specified by `server_prefix`. Optional filter argument. By default, all server prefixes are used. This option can be used with `-serverinfo`, `-lsuinfo`, and `-imageinfo`. The following are valid prefixes:
- `ntap:`
 - `STSBasicDisk:`
 - `PureDisk:`
- `-stype server_type`
 Specifies the vendor specific string that identifies the OpenStorage storage server type. This option applies only to the OpenStorage disk type.

EXAMPLES

Example 1

List the attributes of the NearStore storage server named apricot:

```
bpstsinfo -serverinfo -serverprefix "ntap:" -servername apricot
ServerInfo:
  Server Name: apricot
  Supported Stream Formats:
  [
    TAR
  ]
  Server Flags: (STS_SRV_IMAGELIST | STS_SRV_CRED | STS_SRV_CONRW)
  Media: (STS_LSU_MEDIUM_DISK)
  Maximum Connections: 128
  Current Connections: 4
  Supported Interfaces:
  [
    10.80.104.74
  ]
  Supported Credentials:
  [
    STS_CRED_MD5
  ]
```

Example 2

List the attributes of the `lsu /vol/dsu1` on NearStore storage server apricot:

```
bpstsinfo -lsuinfo -serverprefix "ntap:" -servername apricot
-lsuname /vol/dsul
LsuInfo:
  Server Name: mmnetapp2
  LSU Name: /vol/dsul
  Description:
  Attention:
    Severity: STS_ESNONE
    Message:
  Size: 171798691840
  Bytes Used: 8895016960
  Maximum Transfer: 2048
  Block Size: 4096
  Resident Images: 47
  SaveAs: (STS_SA_CLEARF | STS_SA_IMAGE)
  Media: (STS_LSU_MEDIUM_DISK)
```

Example 3

List the attributes of the images on the lsu /vol/dsul on the NearStore storage server apricot:

```
bpstsinfo -imageinfo -serverprefix "ntap:" -servername apricot
-lsuname /vol/dsul
ImageInfo:
  Image Name: monel_1119652734_C1_F1
  Date: 1119652734
  Full Date:
  Policy: db_backup
  SaveAs: (STS_SA_CLEARF | STS_SA_IMAGE)
  Stream Format: TAR
  Type: STS_IMG_FULL
  Server Name: apricot
  LSU Name: /vol/dsul
  Size: 17596416
  Block Size: 8192
  Exports:

/vol/dsul/nbu_monel_C1_F1.CLF_db_backup_0000 (STS_EXFS_NFS)
  Status: (STS_II_IMAGE_CREATED | STS_II_FILES_CREATED)
```

Example 4

List the version number and prefix for all OpenStorage plugins on your system:

```
bpstsinfo -plugininfo
Plugin Info:
  Plugin Name: libstspishareddiskMT.so
  Prefix: shareddisk:
  Label: SharedDisk (VxFI)
  Build Version: 9
  Build Version Minor: 3
  Operating Version: 9
  Vendor Version:

  Plugin Name: libstspibasicdiskMT.so
```

```
Prefix: STSBasicDisk:  
Label: BasicDisk Plugin  
Prefix: AdvancedDisk:  
Label: Advanced Disk Plugin  
Build Version: 9  
Build Version Minor: 3  
Operating Version: 9  
Vendor Version:
```

```
Plugin Name: libstspinearstoreMT.so  
Prefix: ntap:  
Label: Nearstore Plugin  
Build Version: 9  
Build Version Minor: 3  
Operating Version: 9  
Vendor Version: Protocol Version = 3
```

bpstuadd

NAME

bpstuadd - create NetBackup storage unit or storage group

SYNOPSIS

```
install_path\NetBackup\bin\admincmd\bpstuadd -label storage_unit_label  
-path path_name [-dt disk_type] | -dp disk_pool [-dt disk_type] |  
-density density_type [-rt robot_type -rn robot_number] [-host  
host_name] [-cj max_jobs] [-odo on_demand_only_flag] [-flags flags]  
[-cf clearfiles] [-tt transfer_throttle] [-hwm high_water_mark] [-lwm  
low_water_mark] [-okrt ok_on_root] [-mfs max_fragment_size] [-maxmpx  
mpx_factor] [-nh NDMP_attach_host] [-nodevhost] [-verbose] [-hostlist  
host_name...] [-M master_server,...] [-help]
```

```
install_path\NetBackup\bin\admincmd\bpstuadd -group storage_unit_group  
storage_unit_label,... [-sm selection_method]
```

Note: For Pre-NetBackup 6.0 media servers, the `-tt`, `-hwm`, `-lwm`, and `-okrt` options are ignored and set appropriately.

DESCRIPTION

The `bpstuadd` command creates a NetBackup storage unit or storage unit group. When you create a single storage unit, make sure that you include a label for the new storage unit: either the `-density` the `-path`, or the `-dp` option. `bpstuadd` cannot create the storage unit if the master server has already created the maximum number of storage units that its NetBackup configuration allows. The command does not create a storage unit that specifies the same destination medium as an existing storage unit.

Note: This command does not enable you to change a disk storage unit (DSU) or a tape storage unit to a disk staging storage unit (DSSU). In addition, you cannot change a DSSU to a DSU or a tape storage unit.

NetBackup has several types of storage units. The storage-unit type affects how NetBackup stores the data. The options on the `bpstuadd` command line determine one of the following:

- **Disk.** The storage destination is a disk file system directory and/or a disk pool.

- **Disk Staging.** A disk staging storage unit (DSSU) addresses the automatic (or scheduled sweeping) of images from the DSSU to the final storage unit.
- **Media Manager.** The storage destination is a medium (a tape or optical device) managed by the Media Manager.
- **NDMP.** An NDMP is a storage unit that Media Manager controls. The NetBackup for NDMP option must be installed. In this command description, references to Media Manager storage-unit types also apply to the NDMP storage-unit type except where specifically mentioned. The media for an NDMP storage unit always attach directly to an NDMP host and cannot be used to store data for other NetBackup clients. To define an NDMP storage unit, run the `bpstuadd` command on the Master Server. Refer to the *NetBackup for NDMP Administrator's Guide* for more information on how to add NDMP storage units.

Errors go to `stderr`. A log of the command activity goes to the NetBackup admin log file for the current day.

See the *NetBackup Administrator's Guide* for more information on storage units.

Only authorized users can run this command.

For more information about NetBackup authorization, refer to the *NetBackup Security and Encryption Guide*.

OPTIONS

`-cf clearfiles`

Enables the Nearstore P3 feature to share at the block-level and reduces the total amount of disk space being used. This value is valid for disk storage units only. The `clearfiles` variable can be one of the following values:

- 0 - Data is backed up, bit for bit, like a backup to a BasicDisk.
- 1 - Nearstore enables the block level share function.
- 2 - Enables both clear files and block level share functions.

`-cj max_jobs`

Specifies the maximum number of concurrent jobs that are permitted for this storage unit. `max_jobs` is a non-negative integer. The appropriate value depends on your server's ability to run multiple backup processes comfortably and the available space on the storage media. Also, refer to "Maximum Jobs per Policy" in the *NetBackup Administrator's Guide*.

The `max_jobs` option set to zero (0) means that this storage unit is never selected when a job is scheduled. The default is 1.

`-density density_type`

Specifies the density type of the media. If this option is present, the storage unit type is Media Manager. This option has no default. Either `-density`,

`-path`, or `-dp` must be on the command line. If you have specified the robot type on the command line, the value for *density* should be consistent with the robot type. The `-density`, `-path`, and `-dp` options can only be used independently.

Valid *density* types are:

`d1t` - DLT Cartridge

`d1t2` - DLT Cartridge alternate

`8mm` - 8mm Cartridge

`4mm` - 4mm Cartridge

`qscsi` - 1/4 Inch Cartridge

Note: NetBackup supports the following densities on NetBackup Enterprise Servers.

`hcart` - 1/2-inch cartridge

`hcart2` - 1/2-inch cartridge alternate

`dtf` - DTF Cartridge

`odiskwm` - Optical Disk Write-Many

`odiskwo` - Optical Disk Write-Once

`-dp` *disk_pool*

Specifies the name of the disk pool, which is the data storage area for this storage unit. The disk pool must already exist.

`-dt` *disk_type*

Enables the user to specify a disk type. The following are the valid values for *disk_type*:

1 - BasicDisk

2 - NearStore

3 - SnapVault

6 - DiskPool

`-flags` *flags*

Specifies the storage unit to be a staging storage unit, which allows for a quick restore. Valid values for *flags* are: NONE and STAGE_DATA. Currently valid for only disk storage units.

`-group` *storage_unit_group storage_unit_label...*

Adds a storage unit group and specifies the group name and the storage unit(s) that comprise the group. Add multiple storage units to the storage unit group by separating the names with a space. The maximum length of a storage unit group label is 128 characters.

`-help`

Prints a command line usage message when `-help` is the only option on the command line.

`-host host_name`

Indicates a single specific media server that is associated with the storage unit. Only this media server can be selected as the system to read or write from the storage. The default is the host name of the local system.

Note: NetBackup Server does not support remote media servers.

The host you select must be either your NetBackup master server or a remote media server (if you configure remote media servers). The host name must be the network name for the server as known by all NetBackup servers and clients.

If *host_name* is a valid network name, but was not configured previously in NetBackup, it is added to NetBackup's configuration as a media server. On UNIX, this server shows up as a `SERVER` entry in the `bp.conf` file; on Windows, Host Properties specifies the server in the Servers list. If *host_name* is not a valid network name, you must configure it manually.

`-hostlist host_name...`

Indicates that a subset of the media servers with access to the storage should be used. Use this option if multiple media servers share a disk pool. You want to dedicate one set of media servers to service a set of policies and clients. Then you want a different set to service other policies and clients (or for a specific role such as duplication jobs).

`-hwm high_water_mark`

Specifies a percentage of a disk storage unit at which it is considered full. This option is a user-configurable threshold. The valid range for the High Water Mark is 0 to 100 (percentage), and the default setting is 98(%). When the High Water Mark is reached, NetBackup becomes proactive in two different scenarios:

- When you run a job and the total capacity is used, the DSU is considered to be Full. If you choose a storage unit in a Storage Unit Group, the following occurs: the media and the device selection (MDS) does not assign a new job to a storage unit whose used capacity exceeds the High Water Mark. Instead, it looks for another storage unit in the group to assign to the job.
- During a job, if the Staging attribute is set and the total capacity is used, staging expires images to free space on the DSU. This action accommodates more backup data.

`-label storage_unit_label`

Specifies the name of the storage unit. This option is required unless you use `-group`. The maximum length of a storage-unit label is 128 characters.

`-lwm low_water_mark`

This option is a user-configurable threshold that the Disk Storage Units that do staging use. The valid range for the Low Water Mark is 0 to 100 (percent). The default setting is 80 (percent).

When the High Water Mark is reached, do one of the following:

- Migrate images to other storage units until the Low Water Mark is reached.

- Free disk space by expiring disk images for the oldest staged images until the Low Water Mark is reached.

If you want to save most of your data, configure the Low Water Mark to be near the High Water Mark.

`-M master_server, . . .`

A list of master servers. This list is a comma-separated list of hostnames. If this option is present, the command is run on each of the master servers in this list. The master servers must allow access by the system that issues the command. If an error occurs for any master server, the process stops at that point. The default is the master server for the system where the command is entered.

`-maxmpx mpx_factor`

The maximum multiplexing factor. Multiplexing sends concurrent, multiple backups from one or several clients to a single drive.

Refer to "Multiplexing (MPX)" in the NetBackup Administrator's Guide.

The multiplexing factor can range from 1 to 32. The default is 1, which means no multiplexing. A value greater than 1 means that NetBackup can create multiplexed images on the destination medium. The license determines the effective subset of the 1 to 32 range for the local NetBackup installation.

`-mfs max_fragment_size`

Specifies the maximum fragment size in megabytes, or how large a fragment a NetBackup image can be. NetBackup supports a maximum fragment size of 1,000,000 megabytes (1 terabyte).

For removable media, this value is zero. Or it is any integer greater than or equal to 50 (megabytes) and less than or equal to 1,048,576 (megabytes) (1024 GB). The default value is 0, which means the maximum of 1,048,576 Mbytes.

For a Disk storage unit, this value ranges from 20 Mbytes to 512,000 Mbytes (512GB). The default value is 512,000 Mbytes.

`-nh NDMP_attach_host`

Specifies the hostname of the NDMP server. If this option is present, the storage unit type is set to NDMP. The default is no NDMP server.

`-nodevhost`

Indicates that no media server is associated with this storage unit. You can select any media server that can access the storage to move the data (such as backup, duplicate, restore).

`-odo on_demand_only_flag`

The On-Demand-Only flag controls the condition under which NetBackup uses the storage unit:

- To make the storage unit available only to the policies or the schedules that request it, set the flag to 1 (enabled).
- To make the storage unit available to any policy or schedule, set the flag to 0 (disabled).

If the storage unit type is Disk, the default is 1; NetBackup uses the storage unit only when explicitly requested. Otherwise, the default is 0.

DSSUs are on demand only. They have to be chosen explicitly as a backup target.

`-okrt ok_on_root`

If this flag is not set, neither backups nor directory creation occur on the root file system. If the `ok_on_root` flag is set, then backups and directory creations occur normally.

The default value for this flag is 0. Backups and directory creations to a disk storage unit (BasicDisk) do not occur if the path is on the root file system.

`-path path_name`

Specifies the path to a disk file system that expressed as an absolute pathname, which is the data storage area for this storage unit. When this option is present, the storage unit type is Disk. This option does not have a default. Either `-path`, `-dp` or `-density` must be on the command line. The `-density`, `-path`, and `-dp` options can only be used independently.

In general when this option is used, enable the On-Demand-Only flag (see `-odo`). Otherwise, if you have any NetBackup policies that do not require specific storage units, they can fill the disk filesystem `path_name`. This action can cause serious system problems. For example, if the system swap area happens to be on the same filesystem, new processes may fail.

`-rn robot_number`

Specifies the robot number for this storage unit. The robot number must be greater than or equal to 0. The robot number can be obtained from the Media Manager device configuration. The *NetBackup Administrator's Guide*

discusses the rules that concern the use of this number. This option is ignored unless the `-rt` option is present. This option has no default.

`-rt` *robot_type*

The robot type for this storage unit. For non-robotic (stand-alone) devices select `NONE` or omit this option. The default value is `NONE` (Not Robotic). The value for density should be consistent with the robot type.

If this option is set to any value other than `NONE`, the `-rn` option is required. Available robot type codes are:

`NONE` - Not Robotic

`TLD` - Tape Library DLT

`ACS` - Automated Cartridge System

`TL8` - Tape Library 8MM

`TL4` - Tape Library 4MM

`ODL` - Optical Disk Library

`TSH` - Tape Stacker Half-inch

`TLH` - Tape Library Half-inch

`TLM` - Tape Library Multimedia

`-sm` *selection_method*

Selects the method in which a storage unit group is chosen. This option is valid only for storage unit groups. The possible values for *selection_method* are:

Prioritized = 1 (DEFAULT)

Least Recently Selected = 2

Failover = 3

Load Balance = 4

Option 1: Prioritized, selects the first storage unit in the list until either the unit is down, is full, or its `max-concurrent-jobs` setting is reached. Then the next storage unit in the list is examined and so on until an available one is found.

Option 2: Least Recently Selected, selects the least-recently selected storage unit.

Option 3: Failover is the same as Prioritized except MDS queues a job to wait for the first storage unit if the `max-concurrent-jobs` is reached. MDS moves on to the next storage unit in the list only if the first unit is down or full.

Option 4: Load Balance. If the user selects this option and installed the Capacity Management License key, Media Device Selection (MDS) balances the job load. It balances the job load by considering if a media server meets the following conditions:

- Enough disk volume free space available to accommodate the estimated job size.
- Enough CPU and memory resources available to accommodate another job.
- Least amount of estimated job size data being processed compared to other media servers of the same class or rank.

If the user does not have the Capacity Management license key, then Load Balance reverts to Option 2 behavior. It selects the least-recently selected storage unit.

`-tt transfer_throttle`

The Transfer Throttle setting appears for SnapVault storage units only.

The setting indicates the maximum SnapVault data transfer bandwidth. A setting of zero (default) indicates an unlimited bandwidth and data transfer would occur at the full network bandwidth. (Range: 0 (default) to 9999999.)

`-verbose`

Select verbose mode for logging. This option is meaningful only when it runs with debug log function on (that is, when the following directory is defined):

`install_path\NetBackup\logs\admin`

EXAMPLES

Example 1

Create a new storage unit, named hatunit. Its storage unit type is Disk.

The path for the storage unit is `C:\tmp\hatdisk`.

```
bpstuadd -label hatunit -path C:\tmp\hatdisk -verbose
<2>bpstuadd: INITIATING: NetBackup 6.0 created: 0
<2>bpstuadd: EXIT status = 0.
```

Example 2

Note: The following example refers to remote media servers and applies only to NetBackup Enterprise Server. NetBackup Server supports only a master server, not remote media servers.

Create a storage unit by using a UNIX server, which has not been configured previously in NetBackup:

```
% bpstuadd -label parrot_stu -host parrot -density dlt -rt TLD -rn 2
```

Remote media server parrot was added to the `bp.conf` file.

You must also install NetBackup and Media Manager on parrot and run the `add_slave_on_clients` executable on the master server.

```
% grep parrot /usr/openv/netbackup/bp.conf
```

```
SERVER = parrot
```

RETURN VALUES

An exit status of 0 means that the command ran successfully.

Any exit status other than 0 means that an error occurred.

If the administrative log function is enabled, the exit status is logged in the administrative daily log under the log directory:

```
install_path\NetBackup\logs\admin
```

It has the following form:

```
bpstuaddnew: EXIT status = exit status
```

If an error occurred, a diagnostic precedes this message.

FILES

```
install_path\NetBackup\logs\admin\*
```

EMM database

SEE ALSO

bpstudel, bpstulist, bpsturep

bpstudel

NAME

bpstudel - delete NetBackup storage unit or storage unit group

SYNOPSIS

```
install_path\NetBackup\bin\admincmd\bpstudel -label storage_unit_label  
[-verbose] [-M master_server [,...]]  
  
install_path\NetBackup\bin\admincmd\bpstudel -group storage_unit_group  
[-M master_server [,...]]
```

DESCRIPTION

The `bpstudel` command deletes a NetBackup storage unit or storage unit group. The command must include either a label name for the storage unit or a group name for the storage unit group, but not both.

If `bpstudel` cannot delete the storage unit (for example, the storage unit label is mistyped), it does not return an error message. You can run `bpstulist` to verify that the storage unit was deleted.

Errors are sent to `stderr`. A log of the command's activity is sent to the NetBackup admin log file for the current day.

See the *NetBackup Administrator's Guide* for additional information on storage units.

Any authorized user can run this command.

For more information about NetBackup authorization, refer to the *NetBackup Security and Encryption Guide*.

OPTIONS

- `-label storage_unit_label`
The name of the storage unit. This option is required. The maximum length for a storage-unit label is 128 characters.
- `-group storage_unit_group`
Deletes the specified storage unit group the name. If this option is present, the named storage unit group is deleted.
- `-M master_server [,...]`
Runs this command on each of the master servers in this list. This list is a comma-separated list of master servers. The master servers must allow access by the system that issued the command. If an error occurs for any

master server, the process stops at that point. The default is the master server for the system where the command is entered.

`-verbose`

Selects the verbose mode for logging. This mode is meaningful only when you run with the debug log function on (that is, when the following directory is defined):

`install_path\NetBackup\logs\admin`

EXAMPLES

Delete the storage unit named `tst.dsk` and list the existing storage units before and after the deletion:

```
bpstulist
stuunit 0 mango 0 -1 -1 1 0 C:\tmp\stuunit 1 1 2000 *NULL*
tst.dsk 0 mango 0 -1 -1 3 0 C:\hsm3\dsk/ 1 1 2000 *NULL*

bpstudel -label tst.dsk
```

```
bpstulist
stuunit 0 mango 0 -1 -1 1 0 C:\tmp\stuunit 1 1 2000 *NULL*
```

FILES

`install_path\NetBackup\logs\admin*`
EMM database

SEE ALSO

`bpstuadd`, `bpstulist`, `bpsturep`

bpstulist

NAME

`bpstulist` - display one or all of NetBackup storage units or storage unit groups

SYNOPSIS

```
install_path\NetBackup\bin\admincmd\bpstulist -label storage_unit_label  
[,...] [-L | -l | -U | -show_available | -lsa ] [ -g | -go ] [-verbose]  
[-M master_server [,...]]  
  
install_path\NetBackup\bin\admincmd\bpstulist -group storage_unit_group  
[-verbose] [-M master_server [,...]]
```

DESCRIPTION

The `bpstulist` command displays the attributes for a NetBackup storage unit or storage unit group. If no storage label or storage unit group name is specified, `bpstulist` displays the attributes for all NetBackup storage units or storage unit groups. In addition, this command accepts a comma-separated list of storage unit labels and displays the information for each of the storage units. The `-show_available` and `-lsa` flags provide you with a way to list all of the configured media servers for a particular storage unit.

Errors are sent to `stderr`. A log of the command's activity is sent to the NetBackup admin log file for the current day.

See your *NetBackup Administrator's Guide* for more information on storage units.

Any authorized user can run this command.

For more information about NetBackup authorization, refer to the *NetBackup Security and Encryption Guide*.

OPTIONS

List-type options:

`-L`

The list type is long. This option produces a listing with one storage unit attribute per line, in the format `storage-unit attribute: value`. Some attribute values are expressed in both interpreted form and raw form. For instance, a robot-type entry might be `TL4 (7)` (7 is NetBackup's internal value for a TL4 robot).

For a disk storage unit, a long listing has these attributes for each storage unit:

- Label
- Storage Unit Type (For example, Disk (0))
- Media Subtype (For example, BasicDisk (1))
- Host Connection
- Concurrent Jobs
- On Demand Only
- Path
- Robot Type (not robotic)
- Max Fragment Size
- Max MPX
- Stage data
- Block sharing
- File System Export
- High Water Mark
- Low Water Mark
- Ok On Root

A long listing has these attributes for each DiskPool disk storage unit:

- Label
- Storage Unit Type
- Media Subtype (DiskPool (6))
- Host Connection (one host per line)
- Concurrent Jobs
- On Demand Only
- Max Fragment Size
- Max MPX
- Block sharing
- File System Export

A long listing has these attributes for each Media Manager storage unit:

- Label
- Storage Unit Type (For example, Tape (0))
- Host Connection
- Concurrent Jobs
- On Demand Only

- Robot Type
- Max Fragment Size
- Max MPX/drive

-l

The list type is short, which produces a terse listing. This option is useful for the scripts or the programs that rework the listing contents into a customized report format. This option is the default list type.

A single line contains the information for a storage unit, with all attribute values expressed in raw form. The fields on this line are:

- label
- storage unit type
- host
- robot_type
- robot_number
- density
- concurrent_jobs
- initial_mpx
- path
- on_demand_only
- max_mpx
- maxfrag_size
- ndmp_attach_host
- throttle (SnapVault only)
- subtype
- disk_flags
- high_water_mark
- low_water_mark
- ok_on_root
- disk_pool
- host_list (one or more comma delimited)

-U

The list type is user. This option produces a listing with one storage-unit attribute per line, in the format *storage-unit attribute: value*. Attribute values are expressed in interpreted form. For instance, a robot-type value might be `TL4`, instead of 7.

For a disk storage unit, a user-type list has these attributes for each storage unit:

- Label
- Storage Unit Type (the storage-unit type)
- Storage Unit Subtype
- Host Connection
- Concurrent Jobs
- On Demand Only
- Max MPX
- Path
- Max Fragment Size
- Stage data
- High Water Mark
- Ok On Root

For a DiskPool disk storage unit, a user-type list has these attributes for each storage unit:

- Label
- Storage Unit Type
- Host Connection (one host per line)
- Concurrent Jobs
- On Demand Only
- Max Fragment Size
- Max MPX
- DiskPool

For a Media Manager storage unit, a user-type list has these attributes for each storage unit:

- Label
- Storage Unit Type
- Storage Unit Subtype
- Host Connection
- Concurrent Jobs
- On Demand Only
- Max MPX/drive
- Robot Type
- Max Fragment Size

-g

This list type causes the storage unit list to include the storage unit groups. The format of this option produces a listing with one storage unit group per line, in the format *group_name: group_members*. This option also includes the Selection Method value at the beginning of the Storage Unit Group List.

-go

This list type causes the storage unit list to include only information on the storage unit groups.

-label *storage_unit_label1* [,*storage_unit_label2*...]

Specifies the name of the storage unit. This list is a comma-separated list of storage unit labels. If this option is not present, the listing is for all storage units. The maximum length for a storage-unit label is 128 characters.

-group *storage_unit_group*

Specifies a list of defined storage units and storage unit groups. For the list of storage units, the list type is short, which produces a terse listing. The list of storage unit groups is in the format *group_name: group_members*.

-lsa

Lists all storage units in the database including any available media servers on the media server list.

-M *master_server1* [,*master_server2*...]

Specifies a comma-separated list of master servers. If this option is present, the command is run on each of the master servers in this list. The master servers must allow access by the system that issued the command. If an error occurs for any master server, the process stops at that point in the list. The default is the master server for the system where the command is entered.

-show_available

Lists all storage units in the database including any available media servers on the media server list.

-verbose

Select verbose mode for logging. This mode is meaningful when only you run with the debug log function on (that is, when the following directory is defined):

install_path\NetBackup\logs\admin

EXAMPLES

Example 1

List the storage units that defined on the master server apricot by using the `-U display option`:

```
bpstulist -U -M apricot
```

```
Label:                redtest
Storage Unit Type:    Disk
Host Connection:      apricot
Concurrent Jobs:      1
On Demand Only:       yes
Max MPX:              4
Path:                 /usr/redtest
Max Fragment Size:    512000 MB

Label:                bluetest
Storage Unit Type:    Media Manager
Host Connection:      apricot
Number of Drives:     6
On Demand Only:       yes
Max MPX/drive:        1
Density:              4mm - 4mm Cartridge
Robot Type/Number:    TL4 / 0
Max Fragment Size:    1048576 MB
```

Example 2

The following output is realized by using the following `bpstuadd` command to create a regular disk staging storage unit:

```
bpstuadd -label apple -path /tmp/apple -flags STAGE_DATA - creates
a regular Disk STU
```

Short output:

```
apple 0 felix.min.veritas.com 0 -1 -1 1 0 "/tmp/apple" 1 1 2000
*NULL* 0 1 0 98 80 1 apple felix.min.veritas.com
```

Long output:

```
Label:                apple
Media Type:           Disk (0)
Host Connection:      felix.min.veritas.com
Concurrent Jobs:      1
On Demand Only:       yes
Path:                 "/tmp/apple"
Robot Type:           (not robotic)
Max Fragment Size:    512000
Max MPX:              1
Stage data:           no
Block Sharing:        no
File System Export:   no
High Water Mark:      98
Low Water Mark:       80
OK On Root:           no
```

FILES

install_path\NetBackup\logs\admin*
EMM database

SEE ALSO

bpstuadd, bpstulist, bpsturep

bpsturep

NAME

bpsturep - replace selected NetBackup storage unit attributes

SYNOPSIS

```
install_path\NetBackup\bin\admincmd\bpsturep -label storage_unit_label  
[-verbose] [-host host_name | -nodevhost] [-path path_name | -dp  
disk_pool | -density density [-rt robot_type -rn robot_number] [-nh  
NDMP_attach_host] [-cj max_jobs] [-odo on_demand_only_flag] [-mfs  
max_fragment_size] [-maxmpx mpx_factor] [-cf 0 | 1] [-flags flags]  
[-tt transfer_throttle] [-hwm high_water_mark] [-lwm low_water_mark]  
[-okrt ok_on_root] [[-addhost | -delhost] host_name [host_name]]  
[-hostlist host_name [host_name]] [-M master_server [...]]
```

```
install_path\NetBackup\bin\admincmd\bpsturep -group storage_unit_group  
[-addstu | -delstu] storage_unit_label [-M master_server [...]] [-sm  
selection_method]
```

Note: For Pre-NetBackup 6.0 Media Servers, the -tt, -hwm, -lwm, and -okrt options are ignored and set appropriately.

DESCRIPTION

The `bpsturep` command modifies an existing NetBackup storage unit by replacing selected storage-unit or storage-unit-group attributes in the NetBackup catalog. The command line must include a label for the storage unit or a group name for the storage unit group. The label or the group name is the only storage-unit attribute that `bpsturep` cannot modify.

Note: This command does not enable you to change a disk storage unit (DSU) or a tape storage unit to a disk staging storage unit (DSSU). In addition, you cannot change a DSSU to a DSU or a tape storage unit.

Use the `bpsturep` command with care. The changes to the storage unit or storage unit group must be compatible with existing attributes. Make sure resulting attribute combinations are valid, especially for the following attributes:

robot_type
robot_number

density_type
max_fragment_size
path_type
NDMP_attach_host

The safest way to modify these attributes is to run `bpsturep` once for each attribute to be replaced.

`bpsturep` makes the changes by modifying the storage unit with the specified attribute changes. Run `bpstulist` after `bpsturep` to determine whether the intended changes were applied.

Errors go to `stderr`. A log of the command's activity goes to the NetBackup administrative log file for the current day. See your NetBackup system administrator's guide for additional information on storage units.

Any authorized user can run this command.

For more information about NetBackup authorization, refer to the *NetBackup Security and Encryption Guide*.

OPTIONS

`-cf clearfiles`

Enables the Nearstore P3 feature to share at the block-level and reduces the total amount of disk space being used. This value is valid for disk storage units only. The *clearfiles* variable can be one of the following values:

- 0 - Data is backed up, bit for bit, like a backup to a BasicDisk.
- 1 - Nearstore enables the block level share function.
- 2 - Enables both clear files and block level share functions.

`-cj max_jobs`

The maximum number of concurrent jobs that are permitted for this storage unit. *max_jobs* is a non-negative integer. The appropriate value depends on your server's ability to run multiple backup processes comfortably and the available space on the storage media. Also, refer to the Maximum Jobs per Policy topic in the *NetBackup Administrator's Guide*.

0 means that this storage unit is never selected when a job is scheduled. The default is 1.

`-density density_type`

If this option is present, the storage unit type is Media Manager. This option does not have a default. If the command line includes a robot type, the value for density should be consistent with the robot type. The `-density`, `-path`, and `-dp` options can only be used independently.

Valid density types are:

dlt - DLT cartridge
dlt2 - DLT cartridge alternate
8mm - 8mm cartridge
4mm - 4mm cartridge
qscsi - 1/4-inch cartridge

Note: The following densities apply only to NetBackup Enterprise Servers.

hcart - 1/2 Inch Cartridge
hcart2 - 1/2 Inch Cartridge alternate
dtf - DTF Cartridge
odiskwm - Optical Disk Write-Many
odiskwo - Optical Disk Write-Once

-dp *disk_pool*

Specifies the name of the disk pool, which is the data storage area for this storage unit. This option can be used only when the disk type is 6 (DiskPool). The disk pool must already exist.

-dt *disk_type*

Enables the user to specify a disk type. The following are the valid values for *disk_type*:

1 - BasicDisk
2 - NearStore
3 - SnapVault
6 - DiskPool

-flags *flags*

Specifies the storage unit to be a staging storage unit, which allows for a quick restore. Valid values for *flags* are: NONE and STAGE_DATA. Currently valid for only disk storage units.

-group *storage_unit_group*

The name of a storage unit group. This group is the storage unit whose members `bpsturep` adds or deletes. Use `-addstu storage_unit` to add storage units to the group. Use `-delstu storage_unit` to remove storage units from the group.

-host *host_name*

Note: Note: NetBackup Server does not support remote media servers.

The NetBackup host to which the destination media is attached. The default is the hostname of the local system.

The host you select must be either your NetBackup master server or a media server (if you configure media servers). The host name must be the network name for the server as known by all NetBackup servers and clients.

If *host_name* is a valid network name and is not yet configured, the value *host_name* is added to NetBackup's configuration as a media server. On UNIX, this value shows up in `bp.conf`; on Windows, this value shows up in the Configuration window for Servers. If *host_name* is not a valid network name, you must configure it manually.

`-hwm high_water_mark`

This option is a user-configurable threshold. The default setting for the high water mark is 98%. When the high water mark is reached, NetBackup becomes proactive, under two different circumstances:

- When it initiates a job and the total capacity is used, the DSU is considered to be Full. If it selects from multiple storage units in a storage unit group, the following occurs: the media and the device selection (MDS) do not assign new jobs to units that are at or over the high water mark. It looks for another storage unit in the group, to assign to the job.
- During a job, if the Staging attribute is set and the total capacity is used, staging expires images to free space on the DSU. This action occurs to accommodate more backup data.

`-label storage_unit_label`

The name of a storage unit. This unit is the storage unit whose attributes `bpsturep` replaces. This option is required. The maximum length of a storage-unit label is 128 characters.

`-lwm low_water_mark`

This option is a user-configurable threshold, which Disk Storage Units that do staging use. The default setting for the Low Water Mark is 80% (the pre-NetBackup 6.0 behavior is to delete 2 or 10 images).

When the High Water Mark is reached, you should do one of the following:

- Migrate images to other storage units, until the "Low Water Mark" is reached.
- Free disk space by expiring disk images for the oldest staged images, until the "Low Water Mark" is reached.

NOTE: If you want to save most of your available data, configure the Low Water Mark setting near the High Water Mark. In addition, the Low Water Mark must be less than High Water Mark. They cannot be equal settings.

`-mfs max_fragment_size`

The maximum fragment size in megabytes that is specified (how large a fragment for a NetBackup image can be). NetBackup supports a maximum fragment size of 1,000,000 megabytes (1 terabyte).

For a Media Manager storage unit, this value is either zero. Or it is any integer greater than or equal to 50 megabytes (MB) and less than or equal to 1,048,576 megabytes (MB) or (1024 GB). The default value is 0, which is equivalent to the largest value that is allowed, 1024 GB.

For a Disk storage unit, this value ranges from 20 megabytes to 2000 megabytes (2 gigabytes). The default value is 524288 (512 GB).

`-maxmpx mpx_factor`

The maximum multiplexing factor. Multiplexing sends concurrent, multiple backups from one or several clients to a single drive.

Refer to the topic "Multiplexing (MPX)" in your NetBackup system administrator's guide.

The multiplexing factor can range from 1 to 32, where 1 means no multiplexing. A value greater than 1 means that NetBackup can create multiplexed images on the destination medium. Depending on the licensing of the local NetBackup installation, it may not be possible to assign multiplexing factors in the entire range 1..32.

The default is 1.

`-M master_server [,...]`

Specifies a list of master servers. This list is a comma-separated list of host names. If this option is present, the command is run on each of the master servers in this list. The master servers must allow access by the system that issued the command. If an error occurs for any master server, the process stops at that point in the list. The default is the master server for the system where the command is entered.

`-nh NDMP_attach_host`

Specifies the hostname of the NDMP server. If this option is present, the storage unit type is set to NDMP. The default is no NDMP server.

`-nodevhost`

Indicates that no media server is to be associated with this storage unit.

`-odo on_demand_only_flag`

The *on-demand-only* flag controls whether the storage unit is used only for the backups that explicitly request (demand) the storage unit:

To make the storage unit available only to the policies or the schedules that request it, set the flag to 1 (enabled).

To make the storage unit available to any policy or schedule, set the flag to 0 (disabled).

If the storage unit's type is Disk, the default is 1; NetBackup uses the storage unit only when explicitly requested. Otherwise, the default is 0.

`-okrt ok_on_root`

If this flag is not set, neither backups nor directory creation occurs on the root file system. If the `ok_on_root` flag is set, then backups and directory creations happen normally.

The default value for this flag is 0. (The pre-NetBackup 6.0 setting is 1.) Backups and directory creations to a disk storage unit (BasicDisk) do not occur if the path is on the root file system.

Note: Root on Windows is the Volume where the `windows\system` directory resides.

`-path path_name`

The path to a disk file system, expressed as an absolute pathname, the data storage area for this storage unit. When this option is present, the storage unit type is `Disk`. This option does not have a default. The `-density`, `-path`, and `-dp` options can only be used independently.

In general when this option is used, enable the *on-demand-only* flag (see `-odo`). Otherwise, if you have any NetBackup policies that do not require a specific storage unit, they can fill the disk file system `path_name`. This action can cause serious system problems. For instance, if the system swap area happens to be on the same file system, new processes may fail.

If the path name is defined as a disk staging storage unit (DSSU), use this option to change the path name a different DSSU. It cannot be used to change a DSSU to a different type of storage unit.

`-rn robot_number`

The robot number for this storage unit. The robot number must be greater than or equal to 0. The robot number can be obtained from the Media Manager device configuration. The *NetBackup Administrator's Guide* discusses the rules that concern the use of this number. This option is ignored unless the `-rt` option is present. This option does not have a default.

`-rt robot_type`

The robot type for this storage unit. For non-robotic (stand-alone) devices select `NONE` or omit this option. The default value is `NONE` (Not Robotic). The value for density should be consistent with the robot type

If this option is set to any value other than `NONE`, the `-rn` option is required.

Available robot type codes are:

`NONE` - Not Robotic

TLD - Tape Library DLT
ACS - Automated Cartridge System
TL8 - Tape Library 8MM
ODL - Optical Disk Library
TSH - Tape Stacker Half-inch
TLH - Tape Library Half-inch
TLM - Tape Library Multimedia

`-sm` *selection_method*

Selects the method in which a storage unit group is chosen. This option is valid only for storage unit groups. The possible values for *selection_method* are:

Prioritized = 1 (DEFAULT)

Least Recently Selected = 2

Failover = 3

Load Balance = 4 (appears if Capacity Management license key is installed)

Option 1: Prioritized is the default condition. It selects the first storage unit in the list until either the unit is down or full, or its max-concurrent-jobs setting is reached. Then the next storage unit in the list is examined and so on until an available one is found.

Option 2: Least Recently Selected selects the least-recently selected storage unit.

Option 3: Failover is the same as Prioritized except MDS queues a job to wait for the first storage unit if the max-concurrent-jobs is reached. MDS moves to the next storage unit in the list only if the first unit is down or full.

Option 4: Load Balance. For this option to appear, make sure that you have installed the Capacity Management license key. If the user selects this option, Media Device Selection (MDS) balances the job load by considering if a media server meets these conditions:

- Enough disk volume free space available to accommodate the estimated job size.

- Enough CPU and memory resources available to accommodate another job.

- Least amount of estimated job size data being processed compared to other media servers of the same class or rank.

If the license expires, then Load Balance reverts to Option 2 behavior. It selects the least-recently selected storage unit.

`-tt` *transfer_throttle*

The Transfer Throttle setting appears for SnapVault storage units only.

The setting indicates the maximum SnapVault data transfer bandwidth. A setting of zero (default) indicates an unlimited bandwidth and data transfer would occur at the full network bandwidth. (Range: 0 (default) to 9999999.)

`-verbose`

Select `verbose` mode for logging. This mode is meaningful only when it runs with the debug log function on (that is, when the following directory is defined):

`install_path\NetBackup\logs\admin`

EXAMPLES

Change the path for a disk storage unit, `mkbunit`. The path is changed from

`C:\tmp\mkbunit` to `C:\tmp\mkbunit2`:

```
bpstulist
mkbunit 0 beaver 0 -1 -1 1 0 C:\tmp\mkbunit 1 1 2000 *NULL*
bpsturep -label mkbunit -path C:\tmp\mkbunit2
bpstulist
mkbunit 0 beaver 0 -1 -1 1 0 C:\tmp\mkbunit2/ 1 1 2000 *NULL*
```

FILES

`install_path\NetBackup\logs\admin*`

EMM database

SEE ALSO

`bpstuadd`, `bpstudel`, `bpstulist`

bptestbpcd

NAME

bptestbpcd - test bpcd connections and verify connect options

SYNOPSIS

```
install_path\NetBackup\bin\admincmd\bptestbpcd [-connect_options 0|1|2  
0|1|2 0|1|2|3] [-host host_name] [-client client_name] [-M server]  
[-wait_to_close seconds] [-verbose]
```

DESCRIPTION

The `bptestbpcd` command attempts to establish a connection from a NetBackup server to the `bpcd` daemon on another NetBackup system. If successful, it reports information about the sockets that are established.

The first line of output is three digits that represent the effective connect options. The first digit is 0 if reserved ports are used and 1 if non-reserved ports are used. The second digit is 0 if legacy (random port) call-back is used and 1 if `vnetd` call-back is used. The third digit is 1 if the connection is initiated on the `vnetd` port number. The third digit is 2 if the connection is initiated on the legacy `bpcd` port number.

The second and third lines display the following items: the NetBackup server IP address and port number, the connection direction, and the `bpcd` IP address and port number for the first two established sockets. If the connection is to a NetBackup client, a third socket is established. The following items appear in an additional line: the NetBackup server IP address and port number, the direction of the connection, and the `bpcd` IP address and port number.

OPTIONS

`-connect_options 0|1|2 0|1|2|3 0|1|2|3`

The first setting indicates the type of port to use to connect to `bpcd` on the client:

0 = Use a reserved port number.

1 = Use a nonreserved port number. If you select this option, enable Allow Nonreserved Ports for the client. See the Universal Settings dialog under Host Properties > Media Servers.

See "Accept connections on non-reserved ports" in the NetBackup Administrator's Guide, Volume I, Unix and Linux.

2 = Use the value that the DEFAULT_CONNECT_OPTIONS configuration entry on the server defines.

The second setting indicates the bpcd call-back method to use to connect to the client:

0 = Use the traditional call-back method.

1 = Use the vnetd no call-back method.

2 = Use the value that the DEFAULT_CONNECT_OPTIONS configuration entry on the server defines.

The third setting indicates the connection method to use to connect the client:

0 = Connect to a daemon on the client using vnetd if possible, otherwise, connect by using the traditional port number of the daemon.

1 = Connect to a daemon on the host using vnetd only.

2 = Connect to a daemon on the server by using the traditional port number of the daemon only.

3 = Use the value that the DEFAULT_CONNECT_OPTIONS configuration entry on the server defines.

If `-connect_options` is not specified, the configured connect options from the client database, the `CONNECT_OPTIONS` configuration entry, or the `DEFAULT_CONNECT_OPTIONS` configuration entry is used.

`-client` *client_name*

The client name of the system to connect to. If neither `-host` nor `-client` is specified, the host name of the local system is used.

`-host` *host_name*

The host name of the system to connect to. Typically, *host_name* is the host name of a NetBackup server. If neither `-host` nor `-client` is specified, the host name of the local system issued.

`-M` *server*

The host name of the NetBackup server that initiates the connection. If `-server` is specified, the host name of the local system is used.

`-wait_to_close` *seconds*

Number of seconds to wait before you close the sockets after the connection to bpcd is established. The default is 0.

`-verbose`

Display additional information about the bpcd host or client such as the bpcd protocol number.

EXAMPLES

Example 1

In this example, a connection from the local system to server *fred* is attempted by using the legacy connect options:

```
# cd /usr/opensv/netbackup/bin/admincmd
# ./bptestbpcd -host fred -connect_options 0 0 2
0 0 2
10.0.0.32:748 -> 10.0.0.59:13782
10.0.0.32:983 <- 10.0.0.59:635
```

Example 2

In this example, a connection from the server *fred* is attempted to the client *barney* by using the *vnetd* port number if possible:

```
# cd /usr/opensv/netbackup/bin/admincmd
# ./bptestbpcd -M fred -client barney -connect_options 2
2 0
1 1 1
10.0.0.59:40983 -> 10.0.0.104:13724
10.0.0.59:40984 -> 10.0.0.104:13724
10.0.0.59:40985 -> 10.0.0.104:13724
```

bpup

NAME

bpup - start NetBackup services on Windows systems

SYNOPSIS

```
install_path\NetBackup\bin\bpup [-h] [-S|v] [-f] [-a] [-c] [-d] [-m] [-n]  
[-s]
```

DESCRIPTION

The bpup command is used to start NetBackup services including the NetBackup databases, Media Manager, and clients.

OPTIONS

- h
Displays the help screen.
- S
Enables you to select silent mode. With this option, no listing is generated and no confirmation is requested.
- v
Selects the verbose mode and generates a detailed listing.
- f
Forces the startup of the NetBackup services without prompting the user for a confirmation.
- c
Starts the client.
- d
Starts the NetBackup database.
- m
Starts Media Manager.
- n
Starts the NetBackup services.
- s
Starts the server and not the client (NetBackup Media Manager).

SEE ALSO

`bpdown`

bpverify

NAME

`bpverify` - verify the backups that NetBackup creates

SYNOPSIS

```
install_path\NetBackup\bin\admincmd\bpverify [-l] [-p] [-pb] [-v]
[-local] [-client name] [-st sched_type] [-sl sched_label] [-L
output_file [-en]] [-policy name] [-s date] [-e date] [-M
master_server] [-Bidfile file_name] [-pt policy_type] [-hoursago
hours] [[-cn copy number] | [-primary]] [-backupid backup_id] [[-id
media_id or path] | [-stype server_type] [-dp disk_pool_name [-dv
disk_volume]]]
```

DESCRIPTION

`bpverify` verifies the contents of one or more backups by reading the backup volume and by comparing its contents to the NetBackup catalog. This operation does not compare the data on the volume with the contents of the client disk. However, it does read each block in the image, which verifies that the volume is readable. NetBackup verifies only one backup at a time and tries to minimize media mounts and position time.

If either `-Bidfile` or `-backupid` is specified, `bpverify` uses this option as the sole criterion for selecting the set of backups it verifies. If the command line does not contain `-Bidfile` or `-backupid`, then `bpverify` selects the backups that satisfy all the selection options. For instance, if the command line looks like:

```
bpverify -pt Standard -hoursago 10
```

then `bpverify` verifies the set of backups with policy type `Standard` that have been run in the past 10 hours.

If `-p` or `-pb` is specified, `bpverify` previews the set of backups that meet the selection criteria. In this case, `bpverify` displays the backup IDs, but does not perform the verification.

`bpverify` sends its error messages to `stderr`. `bpverify` sends a log of its activity to the NetBackup admin log file for the current day, which are found the following directory:

```
install_path\NetBackup\Logs\admin
```

Any authorized user can run this command.

For more information about NetBackup authorization, refer to the *NetBackup Security and Encryption Guide*.

OPTIONS

`-backupid backup_id`

Specifies the backup ID of a single backup to verify. This option takes precedence over any other selection criteria except `-Bidfile`. The default is any backup.

`-Bidfile file_name`

file_name specifies a file that contains a list of backup IDs to be verified. In addition, this file is removed during the activation of that command line interface (CLI). This file is removed because the NetBackup GUIs commonly use this parameter. The GUIs expect the command-line interface to remove the temporary file that was used for the `-Bidfile` option upon completion. Direct command-line interface users can also use the option, however it removes the file.

The file contains one backup ID per line. If this option is specified, other selection criteria are ignored. The default is no file of backup IDs, which means any backup can be verified.

`-client name`

Specifies the name of the client that produced the original backup. The default is any client.

`-cn copy_number | -primary`

Determines the copy number of the backup ID to verify. Valid values are 1 through the setting that the `bpconfig -max_copies` setting indicates, up to 10. The default is 1.

`-primary` indicates that the primary copy should be verified rather than the copy.

`-dp disk_pool_name [-dv disk_volume]`

Specifies the name of the disk pool, which is the data storage area for this storage unit. Optionally, `bpverify` verifies the images that reside on the specified disk volume only. This option must be used with the `-stype` option. The disk pool must already exist.

`-e date`

Specifies the end of the time range for selecting backups to verify. The `-s` option or the `-hoursago` option specifies the start of the range.

The format of *date* depends on the user's locale setting. See the NOTES section for more information. For the C locale, the date syntax is as follows:

mm/dd/yyyy [hh[:mm[:ss]]]

The default ending time is the current date and time.

-help

Prints a command line usage message when `-help` is the only option on the command line.

-hoursago *hours*

Specifies the number of hours before the current time to search for backups. This number is equivalent to the specification of a start time (`-s`) of the current time minus hours. Do not use both this option and the `-s` option.

Hours is a non-negative integer. The default starting time is 24 hours ago.

-id *media_id* | *path*

Search the image catalog for backups to verify that they are on this media ID or pathname. If a backup has some fragments on this media ID and some fragments on another media ID, NetBackup will verify a spanning image as long as the backup begins on the media of the mediaID provided.

For the images that are stored on disk rather than removable media, specify an absolute pathname instead of *media_id*. The default is any media ID or pathname. BasicDisk and NearStore use this option.

-L *output_file* [-en]

Specifies the name of a file in which to write progress information. The default is not to use a progress file, in which case the progress information is written to `stderr`. For additional information, see DISPLAY FORMATS later in this command description.

Include the `-en` option to generate a log in English. The name of the log contains the string `_en`. This option is useful to the support personnel that assist in a distributed environment where different locales may create logs of various languages.

-l

Specifies that the list type is long, which causes `bpverify` to write additional information to the progress log. The default list type is short. For additional information, see DISPLAY FORMATS later in this command description.

-local

If you initiate `bpverify` from a host other than the master server and do not use `-local` (default), the following occurs: `bpverify` starts a remote copy of the command on the master server.

The remote copy allows the command to be terminated from the **Activity Monitor**.

Use `-local` to prevent the creation of a remote copy on the master server and to run `bpverify` only from the host where it initiated.

If the `-local` option is used, `bpverify` cannot be canceled from the **Activity Monitor**.

`-M master_server`

Specifies the master server that provides the `bpverify` image data. The master server must allow access by the system that issued the `bpverify` command. The default is the master server for the system where `bpverify` is entered:

For NetBackup Server:

The default is always the master server where the command is entered.

For NetBackup Enterprise Server:

If the command is entered on a master server, then that server is the default.

If the command is entered on a remote media server, then the master for that media server is the default.

`-p`

Previews the verification, but does not perform the verification. For additional information, see DISPLAY FORMATS later in this command description.

`-pb`

Previews the verification but does not perform the verification. This option is similar to `-p`, but `-pb` does not display information about the individual backups. For additional information, see DISPLAY FORMATS later in this command description.

`-policy name`

Search for backups to verify in the specified policy. The default is any policy.

`-pt policy_type`

Specifies the policy type for selecting backups to verify. The default is any policy type.

The valid policy types are the following:

AFS

DataStore

DataTools-SQL-BackTrack

DB2

FlashBackup

Informix-On-BAR

Lotus-Notes

MS-Exchange-Server

MS-SharePoint
MS-SQL-Server
MS-Windows
NBU-Catalog
NCR-Teradata
NDMP
NetWare
Oracle
OS/2
SAP
Split-Mirror
Standard
Sybase

`-s date`

Specifies the start of the range of dates and times that include all backups to verify. The `-e` option specifies the end of the range. The format of *date* depends on the user's locale setting. See the NOTES section for more information. For the C locale, the date syntax is as follows:

mm/dd/yyyy [hh[:mm[:ss]]]

The default is 24 hours ago.

`-sl sched_label`

Search for backups to verify that the specified schedule created. The default is all schedules.

`-st sched_type`

Search for backups to verify that the specified schedule type created. The default is any schedule type.

Valid values are:

FULL (full backup)

INCR (differential-incremental backup)

CINC (cumulative-incremental backup)

UBAK (user backup)

UARC (user archive)

NOT_ARCHIVE (all backups except user archive)

`-stype server_type`

A string that identifies the storage server type. Possible values are AdvancedDisk, OpenStorage (*vendorname*), PureDisk, and SharedDisk.

-v

Selects the verbose mode. When `-v` is specified, the debug and progress logs include more information. The default is not verbose.

DISPLAY FORMATS

PREVIEW DISPLAYS:

`bverify` runs a preview by searching for backups and then it displays them.

`bverify` does not verify the backups.

- The `-p` display lists backup IDs that meet the criteria that the `bverify` command-line options set. The `-p` information appears in volume order. For each volume that contains a selected backup, the media ID and server appear. The selected backup IDs that reside on that volume follow them.
- The `-pb` display is a brief version of the `-p` display. It lists the media ID and server for each volume that contains the backups that meet the selection criteria.

VERIFICATION DISPLAYS:

`bverify` creates these displays as it verifies images. If the `bverify` command line contains no option to set the list format, the display format is short. If the command line contains `-l`, the display format is long. If the command line contains both `-l` and `-L`, `bverify` creates a file that contains the progress log.

The verification list appears in volume order.

- In long format, `bverify` displays the following information for each selected backup ID:
 - Policy, schedule, backup ID, media ID or path, and creation time
 - Files that are backed up
 - Any problems that `bverify` detects while verifying the image
 - Whether the image verification is successful or not
- In short format, `bverify` does not list the files that were backed up.

NOTES

The format that you must use for date and time option values varies according to the locale setting. The examples in this command description are for a locale setting of C.

EXAMPLES

Example 1

The following example verifies the backups that ran in the past 36 hours:

```
bpverify -hoursago 36
Verify started Thu Feb 3 11:30:29 2003
INF - Verifying policy mkb_policy, schedule Full
(plim_0949536546), path /tmp/mkbunit, created 02/02/01 18:09:06.
INF - Verify of policy mkb_policy, schedule Full
(plim_0949536546) was successful.
INF - Status = successfully verified 1 of 1 images.
```

Example 2

The following example compares the two preview displays, `-p` and `-pb`:

```
bpverify -p -hoursago 2002
Media id = A00002 Server = plim
Bid = plim_0949616279 Kbytes = 32800 Filenum = 1 Fragment = 1
Bid = gava_0949681647 Kbytes = 12191 Filenum = 2 Fragment = 1
Bid = gava_0949683298 Kbytes = 161 Filenum = 3 Fragment = 1
Bid = gava_0949683671 Kbytes = 11417 Filenum = 4 Fragment = 1
Bid = gava_0949684009 Kbytes = 11611 Filenum = 5 Fragment = 1
Bid = gava_0949684276 Kbytes = 806 Filenum = 6 Fragment = 1
Bid = gava_0949688704 Kbytes = 9869 Filenum = 7 Fragment = 1
Bid = gava_0949688813 Kbytes = 9869 Filenum = 8 Fragment = 1
Bid = gava_0949949336 Kbytes = 10256 Filenum = 9 Fragment = 1
Bid = plim_0949949337 Kbytes = 6080 Filenum = 9 Fragment = 1
Bid = plim_0949949337 Kbytes = 4176 Filenum = 10 Fragment = 2
Bid = gava_0949949686 Kbytes = 10256 Filenum = 11 Fragment = 1
Bid = plim_0949949687 Kbytes = 5440 Filenum = 11 Fragment = 1
Bid = plim_0949949687 Kbytes = 4816 Filenum = 12 Fragment = 2
Bid = gava_0949949902 Kbytes = 10256 Filenum = 13 Fragment = 1
Bid = plim_0949949901 Kbytes = 8832 Filenum = 13 Fragment = 1
Bid = plim_0949949901 Kbytes = 1424 Filenum = 14 Fragment = 2
Bid = plim_0950053561 Kbytes = 10256 Filenum = 15 Fragment = 1

Media id = 400032 Server = plim
Bid = toaster2_0950199621 Kbytes = 298180 Filenum = 1
Fragment = 1
Bid = toaster2_0950199901 Kbytes = 298180 Filenum = 3
Fragment = 1

bpverify -pb -hoursago 200
Media id = A00002 Server = plim
Media id = 400032 Server = plim
```

RETURN VALUES

An exit status of 0 means that the command ran successfully.

Any exit status other than 0 means that an error occurred.

If the administrative log function is enabled, the exit status is logged in the administrative daily log under the log directory:

```
install_path\NetBackup\logs\admin
```

It has the following form:

```
bpverify: EXIT status = exit status
```

If an error occurred, a diagnostic precedes this message.

FILES

```
install_path\NetBackup\logs\admin\*
```

```
install_path\NetBackup\db\error\*
```

```
install_path\NetBackup\db\images\*
```

SEE ALSO

NetBackup Administrator's Guide

cat_convert

NAME

cat_convert - run NetBackup catalog format conversion utility

SYNOPSIS

```
install_path\NetBackup\bin\cat_convert.exe -a2b [-o] [-s] [-v]
    source_file or directory [target_file or directory]

install_path\NetBackup\bin\cat_convert.exe -dump [-short] [-noheader]
    [-nopath] [-nodata] [-srec num] [-erec num] [-sep char] source_file

install_path\NetBackup\bin\cat_convert.exe -check source_file
```

DESCRIPTION

cat_convert converts NetBackup catalog .f files between version 3.4, 4.0v or 4.5 ASCII format and 4.5 or later binary format. It automatically detects the source catalog file format and converts it to the other format. NetBackup 6.5 does not support writing new ASCII catalog images. However, it still supports the ability to read existing ASCII catalog images.

The -dump option enables users to view the contents of the binary catalog image .f (dot-f) files. Run cat_convert -? to see this new option. It echoes the contents of the .f file to stdout in a readable format. It also has helper options to use to limit the output to only certain records in the file or a subset of the output columns.

A new -check option provides a consistency check on specified binary .f files. If cat_convert detects inconsistencies, the utility generates up to four reports depending on the types of inconsistencies reported.

■ Invalid Inode Report

This report lists invalid inodes. The following is an example:

```
Inode Type Problem Name
763657 File      Data xsetremote.ini
1049538 File      Name UNKNOWN
1240334 File      Data Bcabudd$ on 'Data Cluster Node B (s-mtn-1)'.lnk
1432162 File      Data menu-backgr.jpg-5a5e537-7a382b9d.idx
1528335 File      Data Root
1673471 Dir       Name UNKNOWN
1721888 File      Data VAC Regional Office Menu.lnk
2538892 Dir       Data CVS
```

Inode is the inode number of the file or directory that is reported to the catalog.

Type displays whether the item is a file or a directory.

Problem displays whether the the data or the name is the cause of the invalid inode.

Name is the short name of the directory if available, or UNKNOWN if not available.

■ Invalid Directory Report

This report lists inconsistent directories. The following is an example:

Index	Inode	1st Child	1st Dir	Last Child	Next Index	Next Dir	Name
2539	2230	5605F	-1	5605F	788763F	-1	JSP.cla
21281	2229	43380F	-1	1122108F	257809F	56110	fr.tmp
24157	3330	53103F	-1	2688747F	-1F	-1	UNKNOWN
36766	4406	98367F	-1	98367F	-1F	-1	Root
97393	5134	471040F	-1	3136322F	-1F	-1	udst.js
105131	5135	514785F	-1	1325594F	823835F	-1	NEWO.WP
107597	5297	529762F	-1	2625774F	540379F	89162	WNT.ini
114675	1234	575751F	-1	3406262F	784893F	-1	MEM.WPD
215333	1235	-1F	-1	-1F	-1F	-1	UNKNOWN
225464	1236	1420664F	-1	1420666F	-1F	-1	CVS

Total Directories: 150307
 Total Files: 1137006

The following describes the column information in this report:

Index is the relative position of the directory that is reported to the catalog.

Inode is the inode number of the file or directory that is reported to the catalog.

1st Child is the index to the first child (file or directory) under the listed directory. This value is -1 if there is no child. The index is followed by either the character *F* if the first child is a file, or the character *D* if it is a directory.

1st Dir is the index to the first directory under the listed directory. This value is -1 if there is no subdirectory.

Last Child is the index to the last child (file or directory) under the listed directory. This value is -1 if there is no child. The index is followed by either the character *F* if the first child is a file, or the character *D* if it is a directory.

Next Index is the index to the next sibling (file or directory) of the listed file. This value is -1 if there is no sibling. The index is followed by either the character *F* if the next sibling is a file, or the character *D* if it is a directory.

Next Dir is the index to the next sibling directory of the listed directory. This value is -1 if no sibling directory exists.

Name is the short name of the directory if available, or UNKNOWN if not available.

■ Invalid File Report

This report lists inconsistent files. The following is the format of the report:

Index	Inode	Next Index	Name
2364	12180	2368F	Report.doc

```
39774 16642 39776D UNKNOWN
```

The following describes the column information in this report:

Index is the relative position of the file as reported to the catalog.

Inode is the inode number of the file or directory that is reported to the catalog.

Next Index is the index to the next sibling (either a file or directory) of the listed file. This value is -1 if there is no sibling. The index is followed by either the character *F* if the next sibling is a file, or the character *D* if it is a directory.

Name is the short name of the directory if available, or UNKNOWN if not available.

■ Invalid Directory and File Report

This report lists both inconsistent files and directories. The following is the format of the report:

```
Index   Inode   Type           Name
2363    11134   Directory      /Documents/Directory 1
13679   10077   Directory      /Documents/Directory 2
Total Directories: 460724
          Total Files: 3426572
```

The following describes the column information in this report:

Index is the relative position of the file as reported to the catalog.

Inode is the inode number of the file or directory that is reported to the catalog.

Type displays whether the item is a file or a directory.

Name is the short name of the directory if available, or UNKNOWN if not available.

Since this report traverses the directory tree, it may not list all of the files or directories that are reported in the first two reports. Since it provides the fully qualified name of the file or directory, it can be useful in problem resolution. It also provides the total number of files and directories.

These reports are not localized.

You must have administrator privileges to run this command.

OPTIONS

-a2b

Convert NetBackup 3.4, 4.0V, 4.5 ASCII format catalog . *f* file(s) to NetBackup 4.5 binary format . *f* file(s).

-check *source_file*

Checks the consistency of a binary .*f* file. *source_file* must be the fully qualified path. Inconsistencies may be due to faulty FlashBackup or NDMP

type backups. If this utility detects no inconsistencies, it ends silently and returns a zero return code. If the utility detects any inconsistencies, it returns the number of inconsistencies and prints up to three reports depending on the types of inconsistencies reported.

-dump

Enables you to view the contents of catalog image .f files.

-o

Overwrite original catalog file content with the new format that converts. -o cannot be used with *target_file_directory*.

-s

Show statistic information to the console window.

-erec *num*

Modifies the output from the `cat_convert -dump`. Stops the display of records at this record number.

Note: The record number is not necessarily the same as the file number in the first column of the output.

-nodata

Eliminates the data column from the output of the `cat_convert -dump`. The data column can result in large outputs, which are of no interest in some situations.

-noheader

An option that modifies the output from `cat_convert -dump`. An option that modifies the output from the `cat_convert -dump`. Eliminates the column headers.

-nopath

An option that modifies the output from `cat_convert -dump`. An option that modifies the output from the `cat_convert -dump`. Eliminates the path column. The path column can result in large outputs, which are of no interest in some situations.

-sep *char*

An option that modifies the output from `cat_convert -dump`. An option that modifies the output from the `cat_convert -dump`. Use this char to separate the columns instead of the white space default separation. For example, you can use this command to generate a comma-separated output.

-short

An option that modifies the output from `cat_convert -dump`. Limits the output to a subset of the usual columns.

`-srec num`

An option that modifies the output from `cat_convert -dump`. An option that modifies the output from the `cat_convert -dump`. Starts to display the records at this record number.

Note: The record number is not necessarily the same as the file number in the first column of the output.

`-v`

Show current progress information.

Specify either a single source file or an entire directory to convert:

- To specify a target file, the source must be a file.
- To specify a target directory, the source must be a directory.
If the source is a directory, you must use `-a2b`.
The new files that the conversion creates convert to the specified format, and the original file names are used in the target directory.

If you do not specify the target file or directory when you convert source files, the files the conversion process creates have an appended suffix. (`_bin.f` or `_ascii.f`).

If the `catalog .f` file size is more than 4 megabytes, the binary catalog leaves output files separate. It puts them in the `catstore` directory.

EXAMPLES

Example 1

Consider the following command:

```
cat_convert -a2b abc.f
```

If `abc.f` is in ASCII format, the *target_file_path* is `abc_bin.f`.

Example 2

Consider the following command:

```
cat_convert -a2b abc.f C:\usr\tmp\abc1.f
```

`abc.f` is converted to binary and copied to the following directory:

```
C:\usr\tmp\abc1.f
```

Example 3

Consider the following command:

```
cat_convert -a2b C:\home\john\catalog
```

Every ASCII `.f` file in the directory is converted to the NetBackup 4.5 binary format with new file name `*_bin.f`.

Example 4

Consider the following command:

```
cat_convert -a2b abc.f
```

The contents of `abc.f` converts to binary.

Example 5

Consider the following command:

```
cat_convert -dump -short abc.f
```

The contents of `abc.f` appear in `stdout` in a user-readable format.

create_nbdb

NAME

create_nbdb - create NBDB database manually

SYNOPSIS

```
install_path\NetBackup\bin\create_nbdb -db_server server_name [-drop]
[-sz small | medium | large] [-dba new_password] [-data
data_directory] [-index index_directory] [-tlog log_directory] [-mlog
log_mirror_directory]
```

DESCRIPTION

This command is used to create the NetBackup database (NBDB) manually. This command can be used to drop the existing NBDB database, and to recreate it by using non-default parameters that were used during installation. A user can perform the following actions:

- Change the default location of the data, index, and transaction log files
- Change the size of the pre-allocated database files
- Add an additional mirrored transaction log for increased database protection

OPTIONS

Without any options, the create_nbdb command verifies the version of an existing database and is used during upgrades. If a database does not exist, it creates it by using default parameters.

-db_server *server_name*

The name of the ASA server that is located in the server.conf file.

-drop

Used to drop the existing NBDB database.

-sz *small | medium | large*

Changes the size of the pre-allocated database files. During installation, the default size that is used is *small*.

-data *data_directory*

Used to identify the directory of the main database files.

`-dba new_password`

Sets the password for the NBDB and the BMRDB databases for all DBA and application accounts. `nbusql` is the default password that is used during installation. To change only the password for an existing database, use `nbdb_admin -dba new_password`.

`-index index_directory`

Used to identify the directory of the index database files.

`-mlog log_mirror_directory`

Used to create a mirrored log for increased database protection.

`-tlog log_directory`

Identifies the location of the transaction log.

duplicatetrace

NAME

duplicatetrace - trace debug logs for duplicate job(s)

SYNOPSIS

```
install_path\NetBackup\bin\admincmd\duplicatetrace [-master_server name]  
-job_id number [-start_time hh:mm:ss] [-end_time hh:mm:ss] mmddy  
[mmddy ...]
```

```
install_path\NetBackup\bin\admincmd\duplicatetrace [-master_server name]  
-backup_id id [-start_time hh:mm:ss] [-end_time hh:mm:ss] mmddy  
[mmddy ...]
```

```
install_path\NetBackup\bin\admincmd\duplicatetrace [-master_server name]  
[-policy_name name] [-client_name name] [-start_time hh:mm:ss]  
[-end_time hh:mm:ss] mmddy [mmddy ...]
```

DESCRIPTION

duplicatetrace consolidates the debug logs for the specified duplicate job[s] and writes them to standard output. The messages sort by time. *duplicatetrace* attempts to compensate for time zone changes and clock drift between remote servers and clients.

At a minimum, you must enable debug logging for bptm/bpdm on the media server and for the following directory on the master server:

```
install_path\NetBackup\admin
```

For best results, set the verbose logging level to 5. Enable debug logging for bpdbm on the master server and bpcd on all servers and clients in addition to the processes already identified.

If either `-job_id` or `-backup_id` is specified, *duplicatetrace* uses this option as the sole criteria for selecting the duplicate job[s] it traces. The options `-policy_name` or `-client_name` cannot be used with `-job_id` or `-backup_id`. If `-job_id` or `-backup_id` are not specified, then all duplicate jobs that match the specified selection criteria are selected. If none of the following options are specified, all the duplicate jobs that are activated on the days that day stamps (*mmddy*) specify are traced: `-job_id`, `-backup_id`, `-policy_name`, or `-client_name`. If `-start_time`/`-end_time` options are used, then the debug logs in the specified time interval are examined.

If `duplicatetrace` starts with `-backup_id bid`, `duplicatetrace` looks for the duplicate jobs that `bpduplicate` started with `-backup_id bid` where the backup IDs (*bid*) match.

If `duplicatetrace` starts with `-policy_name <policy>`, `duplicatetrace` looks for the duplicate jobs that `bpduplicate` started with `-policy <policy>` option where the policy names (*<policy>*) match.

If `duplicatetrace` starts with `-client_name <client>`, `duplicatetrace` looks for duplicate the jobs that `bpduplicate` started with `-client <client>` option where the client names (*<client>*) match.

duplicatetrace writes error messages to standard error.

You must have administrator privileges to run this command.

OPTIONS

`-master_server`

Name of the master server. Default is the local host name.

`-job_id`

Job ID number of the duplicate job to analyze. Default is any job ID.

`-backup_id`

Backup ID number of the backup image that the duplicate job to analyze duplicates. Default is any backup ID.

`-policy_name`

Policy name of the duplicate jobs to analyze. Default is any policy.

`-client_name`

Client name of the duplicate jobs to analyze. Default is any client.

`-start_time`

Earliest time stamp to start analyzing the logs. Default is 00:00:00.

`-end_time`

Latest time stamp to finish analyzing the logs. Default is 23:59:59.

`mmddy`

One or more "day stamps". This option identifies the log file names (log.mmddy for UNIX, mmddy.log for Windows) that is analyzed.

OUTPUT FORMAT

The format of an output line is:

```
<daystamp>.<millisecs>.<program>.<sequence> <machine>  
<log_line>
```

daystamp

The day of the log in yyyyymmdd format.

millisecs

The number of milliseconds since midnight on the local machine.

program

The name of program (ADMIN, BPTM, BPCD, etc.) being logged.

sequence

Line number within the debug log file.

machine

The name of the NetBackup server or client.

log_line

The line that appears in the debug log file.

EXAMPLES

Example 1

The following example analyzes the log of duplicate job with job ID 3 activated on August 6, 2006.

```
duplicatetrace -job_id 3 080606
```

Example 2

The following example analyzes the log of duplicate jobs that duplicate backup image with backup ID pride_1028666945 executed on August 20, 2006. This command would analyze only those duplicate jobs, which were activated with option -backupid pride_1028666945.

```
duplicatetrace -backup_id pride_1028666945 082006
```

Example 3

The following example analyzes the log of duplicate jobs that are activated on policy *Pride-Standard* and client *pride* on August 16, 2006 and August 23, 2006. This command would analyze only those duplicate jobs, which were activated with options -policy *Pride-Standard* and -client *pride*.

```
duplicatetrace -policy_name Pride-Standard -client_name pride  
081604 082304
```

Example 4

The following example analyzes the log of all duplicate jobs that are activated on August 5, 2006 and August 23, 2006.

```
duplicatetrace 080504 082306
```

importtrace

NAME

`importtrace` - trace debug logs for import job(s)

SYNOPSIS

```
install_path\NetBackup\bin\admincmd\importtrace [-master_server name]  
-job_id number [-start_time hh:mm:ss] [-end_time hh:mm:ss] mmddy  
[mmddy]
```

```
install_path\NetBackup\bin\admincmd\importtrace [-master_server name]  
-backup_id id [-start_time hh:mm:ss] [-end_time hh:mm:ss] mmddy  
[mmddy]
```

```
install_path\NetBackup\bin\admincmd\importtrace [-master_server name]  
[-policy_name name] [-client_name name] [-start_time hh:mm:ss]  
[-end_time hh:mm:ss] mmddy [mmddy]
```

DESCRIPTION

`importtrace` consolidates the debug log messages for the specified import job[s] and writes them to standard output. The messages sort by time.

`importtrace` attempts to compensate for time zone changes and clock drift between remote servers and clients.

At a minimum, you must enable debug logging for `bpbrm`, `bptm`, and `tar` on the media server and for the following directory on the master server:

```
install_path\NetBackup\admin
```

`admin` directory on the master server and for `bpbrm`, `bptm`, and `tar` on the media server. For best results, set the verbose logging level to 5. Enable debug logging for `bpdbm` on the master server and `bpcd` on all servers and clients in addition to the processes already identified.

If either `-job_id` or `-backup_id` is specified, `importtrace` uses this option as the sole criteria for selecting the import job[s] to trace. The options `-policy_name` or `-client_name` cannot be used with `-job_id` or `-backup_id`. If `-job_id` or `-backup_id` are not specified, then all import jobs that match the specified selection criteria are selected. If none of the following options is specified, all the import jobs that are activated on the days that day stamps (*mmddy*) specify are traced: `-job_id`, `-backup_id`, `-policy_name`, or `-client_name`. If `-start_time`/`-end_time` options are used, then the debug logs in the specified time interval are examined.

If `importtrace` starts with `-backup_id id`, `importtrace` looks for the import jobs that `bpimport` started with `-backup_id id` where the backup IDS (*id*) match.

If `importtrace` starts with `-policy_name <policy>`, `importtrace` looks for the import jobs that started with `bpimport` with `-policy <policy>` where the policy names (`<policy>`) match.

If `importtrace` starts with `-client_name <client>`, `importtrace` looks for the import jobs that started with `bpimport` with `-client <client>` where the client names (`<client>`) match.

`importtrace` writes error messages to standard error.

You must have administrator privileges to run this command.

OPTIONS

`-master_server`

Name of the master server. Default is the local host name.

`-job_id`

Job ID number of the import job to analyze. Default is any job ID.

`-backup_id`

Backup ID number of the backup image that the import job imports to analyze. Default is any backup ID.

`-policy_name`

Policy name of the import jobs to analyze. Default is any policy.

`-client_name`

Client name of the import jobs to analyze. Default is any client.

`-start_time`

Earliest time stamp to start analyzing the logs. Default is 00:00:00.

`-end_time`

Latest time stamp to finish analyzing the logs. Default is 23:59:59.

`mmddy`

One or more day stamps. This option identifies the log file names (log.mmddy for UNIX, mmddy.log for Windows) to be analyzed.

OUTPUT FORMAT

The format of an output line is:

```
<daystamp>.<millisecs>.<program>.<sequence> <machine>  
<log_line>
```

daystamp

The day of the log in yyyyymmdd format.

millisecs

The number of milliseconds since midnight on the local machine.

program

The name of program (ADMIN, BPBRM, BPCD, etc.) being logged.

sequence

Line number within the debug log file.

machine

The name of the NetBackup server or client.

log_line

The line that appears in the debug log file.

EXAMPLES

Example 1

The following example analyzes the log of import job with job ID 4 activated on August 6, 2002.

```
importtrace -job_id 4 080602
```

Example 2

The following example analyzes the log of import jobs that import backup image with backup id *pride_1028666945* executed on August 20, 2002. This command would analyze only those import jobs, which were activated with option *-backupid pride_1028666945*.

```
importtrace -backup_id pride_1028666945 082002
```

Example 3

The following example analyzes the log of import jobs that are activated on policy *Pride-Standard* and client *pride* on August 16, 2002 and August 23, 2002. This command would analyze only those import jobs, which were activated with options *-policy Pride-Standard* and *-client pride*.

```
importtrace -policy_name Pride-Standard -client_name pride  
081602 082302
```

Example 4

The following example analyzes the log of all import jobs that are activated on August 5, 2002 and August 17, 2002.

```
importtrace 080502 081702
```

nbdb_admin

NAME

nbdb_admin - start or stop individual databases, and change default password

SYNOPSIS

```
install_path\NetBackup\bin\nbdb_admin -dba new_password | [-start|stop  
[database_name]] | [-vxdbs_nb_data directory] |  
[-vxdbs_nbdb_backup_owner y|n] [-auto_start NONE | NBDB | BMRDB]  
[-list]
```

DESCRIPTION

The `nbdb_admin` command can be used to start or stop the NetBackup database or the BMR database.

The `nbdb_admin` command line utility is required to enable the customer to change the DBA and application passwords. The DBA and application passwords are encrypted and stored in the `vxdbs.conf` file. Secure SSL is used for encryption, and keys are handled in a consistent manner with the rest of NetBackup. The passwords are encrypted with AES-128-CFB by using the NetBackup private key. The permissions on the file enable it to be read or written only by the root user on UNIX or a Windows Administrator.

During installation, the default password of `nbusql` is used for the NBDB and the BMRDB databases for all DBA and application accounts. Note, the same password is used for the NBDB and the BMRDB DBA and application accounts such as `EMM_MAIN`.

OPTIONS

`-auto_start NONE | NBDB | BMRDB`

Sets the databases that are automatically started when the database server is started. Either the NetBackup database (NBDB), or the BMR database (BMRDB) can be specified. The database daemon must be stopped and restarted to take effect. Or the user can elect not to start either database by using `NONE`.

`-dba new_password`

Enables you to change the default password, `nbusql`, for the NBDB and the BMRDB databases for all DBA and application accounts.

`-list`

Lists all database files.

`-start|stop database_name`

Starts or stops the NBDB database that is identified in the `database_name` field. The `database_name` field is optional. Use it to specify the NBDB database or the BMRDB database. The NBDB database is the default for this command.

`-vxdbms_nb_data directory`

This command updates the `VXDBMS_NB_DATA` parameter that is stored in the `bp.conf` file on UNIX systems and in the registry on Windows systems. This parameter contains the main location of the NBDB and the BMRDB databases.

`-vxdbms_nbdb_backup_owner y|n`

This command updates the `VXDMS_NBDB_BACKUP_OWNER` parameter in the `bp.conf` file on UNIX systems and in the registry on Windows systems. This command specifies if the master server owns the backup of the databases that are included in the catalog backup. The default for this parameter is `yes`.

nbdb_backup

NAME

`nbdb_backup` - run the program that is used to make a backup of the databases in a directory

SYNOPSIS

```
install_path\NetBackup\bin\nbdb_backup [-dbn database_name] [-offline  
|-online] destination_directory
```

DESCRIPTION

The `nbdb_backup` command enables the customer to make either an online or offline backup of the ASA database files to a file system directory. Use this command to perform maintenance operations and to make a copy of a database.

OPTIONS

`-dbn database_name`

Sets the database that is identified in *database_name* to be backed up. The possible databases are NBDB and BMRDB. The default is to back up both databases if installed on the server.

`-offline` | `-online`

Enables either an offline or an online backup of the ASA database files. In an online backup, the database is up and in operation during the backup. Offline shuts down the database.

destination_directory

Used to identify the directory where the backup is stored.

nbdb_move

NAME

nbdb_move - move location of the NBDB database files after installation

SYNOPSIS

```
install_path\NetBackup\bin\nbdb_move -data data_directory [-index  
index_directory] [-tlog log_directory] [-mlog log_directory]  
[-config_only]
```

DESCRIPTION

Use `nbdb_move` to move database files from the default directory locations to customer-specified directories to separate data from indexes and transaction logs to improve performance. Users can also use this command to move database files (data files and transaction files) to the default location.

On Windows systems, the default location is

install_path\NetBackupDB\data.

`nbdb_move` moves the database files for both the NBDB and the BMRDB database, if present.

OPTIONS

`-config_only`

This command only updates the configuration files with the directory locations specified. The database files are not moved. Use this command in a recovery situation when the database files were already relocated manually, and they need to save their configuration settings.

`-data data_directory`

Used to move the main database files to the customer-specified directories that *data_directory* designates.

`-index index_directory`

Used to change the directory of the index database files.

`-mlog log_directory`

This option can create a mirrored transaction log and put it in a designated directory location. If a mirrored log already exists, this command can be used to move it to a different location.

`-tlog log_directory`

Used to change the transaction log directory.

nbdb_ping

NAME

`nbdb_ping` - display status of NetBackup database (NBDB) or BMR database (BMRDB).

SYNOPSIS

```
install_path\NetBackup\bin\nbdb_ping [-dbn BMRDB ]
```

DESCRIPTION

The `nbdb_ping` command is used to check and display the status of the NetBackup database (NBDB) or the BMR database (BMRDB). Enter the command with no options to display the status of NBDB.

OPTIONS

-dbn *BMRDB*

Displays the status of the BMRDB database.

nbdb_restore

NAME

nbdb_restore - recover the database that is backed up to a directory using nbdb_backup

SYNOPSIS

```
install_path\NetBackup\bin\nbdb_restore -recover source_directory
```

DESCRIPTION

The nbdb_restore command does a restore and recovery from a backup to a directory using nbdb_backup. The recommended method to protection the Sybase ASA NBDB and BMRDB databases is through the Catalog Backup interfaces.

OPTIONS

-recover source_directory
The location of the backup.

nbdb_unload

NAME

nbdb_unload - unload NetBackup databases (NBDB) or BMR (BMRDB)

SYNOPSIS

```
install_path\NetBackup\bin\nbdb_unload [-dbn database_name] [-t  
tablelist] [-s] destination directory
```

DESCRIPTION

The `nbdb_unload` command unloads the specified database. By default the NBDB database is unloaded. The other value for `-dbn` includes, BMRDB for the Bare Metal Restore database.

Note: The Enterprise Media Manager (EMM) Database is considered a component of the NBDB database. In the future other components will be added to the NBDB such as IRM and POLICY.

This command creates `.dat` files, one for each table in the database or in the table list. Each `.dat` file contains comma-separated lines, one for each row in the table. A `reload.sql` file is also generated. This file contains the SQL statements that are required to reload the database. For example:

```
LOAD TABLE "BmrDb.BMR_Configuration" FROM  
c:\temp\data\345.dat
```

To transfer the destination directory contents to a support machine and use it to create a copy of the customer's database, run the `reload.sql` file.

OPTIONS

`-dbn database_name`

Specifies the database that is to be unloaded.

`-s`

Unloads the schema only - no data is unloaded.

`-t tablelist`

Specifies a comma-separated list of tables to unload instead of all the tables in the database.

destination directory

The directory where a user wants the dump of the data and schema to go.

EXAMPLES

1. To unload the NBDB database (including all of EMM), data and schema:

```
nbdb_unload C:\temp\nbdb_dump
```

2. To unload only the NBDB schema:

```
nbdb_unload -s C:\temp\nbdb_dump
```

3. To unload only the EMM_StorageUnit table (by using fully qualified table names):

```
nbdb_unload -t EMM_MAIN.EMM_StorageUnit C:\temp\emm_stu
```

4. To unload the BMR database:

```
nbdb_unload -dbn BMRDB C:\temp\bmr_dump
```

nbdc

NAME

nbdc - add, modify, or list NetBackup data classifications

SYNOPSIS

```
install_path\NetBackup\bin\nbdc -add -n name -r rank [-v] [-M  
master_server] [-d description]  
install_path\NetBackup\bin\nbdc -L | -l [-v] [-M master_server]  
install_path\NetBackup\bin\nbdc -modify -dc class [-v] [-M master_server]  
[-n name] [-d description] [-r rank]
```

DESCRIPTION

The `nbdc` command names data classifications and sets their rank. Data classifications are labels that the user can attach to backup images. They allow NetBackup to treat different kinds of data differently. Only storage lifecycle policies can use data classifications.

The `nbdc` command can do one of the following:

- Add (`-add`) a new data classification. The new level requires a name and a rank, and optionally, a description and a master server name if multiple master servers are present.
- List (`-L` or `-l`) the data classifications.
- Modify (`-modify`) the name, rank, or description of a specified data classification.

OPTIONS

`-d description`

Specifies the new description for the designated data classification. This description is commentary only.

`-dc class`

Specifies the data classification ID (GUID) to be modified.

`-l`

Lists the data classifications. The output contains only information. The fields do not have names. A line appears for each level with fields that are space delimited.

- L
Lists the data classifications. The field name identifies the output fields. A line is output for each level and is formatted to print within the field headings.
- M *master_server*
Specifies a master server. The default is the local server.
- n *name*
Identifies the new name for the specified data classification. Default names are Platinum, Gold, Silver, and Bronze.
- r *rank*
Identifies the new rank for the specified data classification ID. The rank is the method by which NetBackup determines the importance of a data classification in relation to other data classifications.
- v
Selects the verbose mode for logging.

EXAMPLES

The following example lists all data classifications. Only two levels (ranks) are shown.

```
nbdc -L

Rank: 4
Name: Bronze
Description: "lowest rank"
Classification ID: B1F664D41DD111B2ACFB99708C0940D1

Rank: 1
Name: Platinum
Description: "highest rank"
Classification ID: B4C999D41DD111B2FFFB99704C6660D4
```

The following changes the description of Rank 4 to “really the lowest rank”:

```
nbdc -modify -sl B1F664D41DD111B2ACFB99708C0940D1 -d "really the
lowest rank"
```

SEE ALSO

nbstl, nbstlutil

nbdelete

NAME

`nbdelete` - remove deleted fragments from disk volumes

SYNOPSIS

```
install_path\NetBackup\bin\nbdelete -allvolumes [-force]  
install_path\NetBackup\bin\nbdelete -dt disk_type -media_id name  
[-media_server name] [-storage_server name] [-force]
```

DESCRIPTION

The `nbdelete` command removes all deleted fragments from the disk volumes that are specified on the command line. The `-allvolumes` option removes the fragments from all volumes that contain deleted fragments. The `-dt`, `-media_id`, `-media_server`, and `-storage_server` options specify an individual volume where deleted fragments should be removed.

OPTIONS

- `-allvolumes`
Queries the image list in the EMM database to obtain the list of volumes with deleted fragments. `nbdelete` then removes the fragments from those volumes.
- `-dt disk_type`
Specifies the type of the disk volume.
- `-force`
Removes the database entries whether the disk deletion is successful or not. NetBackup removes image copies at catalog cleanup time and after the disk fragments have been removed. If a problem occurs when you try to delete the fragments, the database entries are retained for the deletion to be retried later. Deletion can fail if one of the following occurs: disk volume is offline, disk volume is corrupted and inaccessible, a hardware or network error occurs, or someone has already manually removed the fragments.
- `-media_id name`
Specifies the name that represents the media ID of the volume whose deleted fragments are to be removed.

`-media_server name`

Specifies the name that represents the media server for the volume whose deleted fragments are to be removed.

`-storage_server name`

Specifies the name that represents the storage server of the volume whose deleted fragments are to be removed.

nbdevconfig

NAME

nbdevconfig - preview, import, create, or inventory disk pools

SYNOPSIS

```
install_path\NetBackup\bin\nbdevconfig -changedp [-noverbose] -stype
server_lifecycle_type -dp disk_pool_name [-add_storage_servers
storage_server...] | [-del_storage_servers storage_server...] [-hwm
high_watermark_percent] [-lwm low_watermark_percent] [-comment
comment] [-M master_server]

install_path\NetBackup\bin\nbdevconfig -changestate [-noverbose] -stype
server_type -dp disk_pool_name [-dv disk_volume_name] -state [UP |
DOWN] [-M master_server]

install_path\NetBackup\bin\nbdevconfig -createdp [-noverbose] -dp
disk_pool_name -stype server_type -storage_servers storage_server...
[-hwm high_watermark_percent] [-lwm low_watermark_percent] [-comment
comment] [-dvlist filename] [-M master_server]

install_path\NetBackup\bin\nbdevconfig -deletedp [-noverbose] stype
service_type -dp disk_pool_name [-M master_server]

install_path\NetBackup\bin\nbdevconfig -importenclr [-noverbose]
-enclosure enclosure_name -storage_servers storage_server... [-hwm
high_watermark_percent] [-lwm low_watermark_percent] [-comment
comment] [-M master_server]

install_path\NetBackup\bin\nbdevconfig -inventorydp [-preview |
-noverbose] -stype server_type -dp disk_pool_name [-media_server
media_server] [-M master_server]

install_path\NetBackup\bin\nbdevconfig -mergedps [-noverbose] -stype
service_type -primarydp disk_group_name -secondarydp disk_pool_name
[-M master_server]

install_path\NetBackup\bin\nbdevconfig -previewenclr [-l|-U] -enclosure
enclosure_name | -storage_server storage_server... [-M master_server]

install_path\NetBackup\bin\nbdevconfig -previewdv -storage_server
storage_server -stype storage_server_type [-media_server media_server]
[-dp disk_pool_name] [-dvlist file_name] [-M master_server]

install_path\NetBackup\bin\nbdevconfig -help operation

install_path\NetBackup\bin\nbdevconfig -creates tests [-noverbose]
-storage_server storage_server -stype server_type -media_server
media_server [-st storage_type]
```

```
install_path\NetBackup\bin\nbdevconfig -deletests [-noverbose]  
-storage_server storage_server -stype server_type
```

DESCRIPTION

Use the `nbdevconfig` command as a command line interface or a menu interface to configure and support disk pool operations. `nbdevconfig` performs the following disk pool operations:

- Preview enclosures (disk arrays) available for disk pool creation
- Import enclosures
- Preview disk volumes
- Create and delete disk pools from an enclosure or from an explicit list of disk volumes
- Merge disk pools
- Inventory disk pools to discover new storage (new volumes, resized volumes, or new LUNs)
- Delete a disk pool from NetBackup and the storage server
- Modify disk pool properties
- Change the state of a disk pool or a disk volume
- Create and delete storage servers

The `vmupdate` command detects whether new tapes have been added to or removed from a robotic library. In the same way, the inventory and the preview options of `nbdevconfig` detect if the storage administrator has changed the composition of the disk pool. An inventory detects if new volumes were added, existing volumes were resized (added more space), or volumes were removed. The inventory operation can also accept new space. (For example, it updates the NBU database with the existence of new disk volumes or configures new volumes from the new space.)

OPTIONS

The following are the `nbdevconfig` command operations.

`-changedp`

Changes the indicated properties of the disk pool. Specify the disk pool name option (`-dp`) and the storage server type (`-stype`) to identify the disk pool uniquely.

`-changestate`

Changes the state of the disk pool or disk volume. If `-dv` is specified, then `-changestate` changes the specified disk volume of the disk pool. Otherwise, it changes the state of the disk pool itself. The value for the state can be UP or DOWN.

`-createdp`

Creates a disk pool from the specified list of disk volumes. Additional properties like High Water Mark and comments can be specified.

`-createts`

Creates a storage server.

`-deletedp`

Deletes the specified disk pool from the NetBackup device database. Expire and delete all images before you run this option.

`-deletets`

Deletes the specified storage server.

`-help operation`

Specifies an operation (`-changestate`, `-deletedp`, `-inventorydp`, ...) for which you want usage information.

`-importenclr`

Creates a disk pool from the specified enclosure. You can also specify additional properties like High Water Mark and comments.

`-inventorydp`

Discover new or changed storage in a disk pool and accept these changes. Storage changes include new volumes, change of volume size, or new LUNs. Use the `-preview` option if you only want to view the details of the changes to the disk pool without accepting them.

Note: For SharedDisk, the `-inventorydp` option resets the freespace value for each LUN to maximum (total capacity) regardless of the actual freespace on the LUN. The first mount of the LUN changes this value to the actual freespace.

`-mergedps`

Merge the specified primary and secondary disk pools.

`-previewdv`

Previews inventory changes to be made, but does not perform the inventory update.

`-previewenclr`

Lists the details of all enclosures (disk arrays) that any disk pool uses or may use.

The following is a description of each of the `nbdevconfig` suboptions. Multiple options may use some of these suboptions (see the Synopsis).

`-comment` *comment*

Adds a comment for the disk pool. Quotation marks (" ") are required if the comment contains any spaces.

`-dp` *disk_pool_name*

Specifies the name of the disk pool that `nbdevconfig` previews, inventories, or creates.

`-dv` *disk_volume_name*

Specifies the name of the disk volume.

`-dvlist` *filename*

Specifies the filename that contains a list of the disk volumes.

`-enclosure` *enclosure_name*

Specifies the unique name of the enclosure. When it is used with the `previewenclr` option, it displays details about the enclosure. This option runs successfully only if the vendor CLI is installed on the master server and its name in the disk array's host map.

When it is used with the `importenclr` option, it creates the disk pool from the specified enclosure.

`-hwm` *high_watermark_percent*

Specifies the percentage of used capacity at which the storage (disk volume) is considered full. No new jobs can be assigned to the volume, and staging expiration operations can be triggered.

`-l`

Sets the list type to short. This option produces parsable output with all fields on one line with no headers. The first field indicates the version of the output as an aid to the script operation.

`-lwm` *low_watermark_percent*

Specifies the percentage of used capacity to which staging and expiration operations drain each volume in the disk pool upon reaching the high watermark.

`-M` *master_server*

Specifies the name of the master server.

`-media_server` *media_server*

Specifies the media server that executes the operation.

`-noverbose`
 Suppresses all `stdout` messages, including successful confirmation output such as "Disk pool *disk_pool_name* was successfully inventoried."

`-st storage_type`
 Specifies the type of storage being used:
 1 -- Formatted disk (default) OR 2 -- Raw disk
 4 -- Direct attached OR 8 -- Network attached (default)
 The two values are added together. For example a *storage_type* of 10 indicates a raw disk (2) that is network attached (8).

`-state UP | DOWN`
 Selects the state of the disk pool or disk volume. Specify UP to up the disk pool or disk volume and DOWN to down the disk pool or disk volume.

`-storage_server storage_server`
 Specifies a single storage server. Interpretation differs depending upon the option that is used with it.

- `previewdv`: `-storage_server` restricts the output to arrays that are connected to the specified servers. All of the hosts must be connected to all storage (LUNs) within the disk volume.
- `createstdv`: `-storage_server` identifies the host name of the storage server.

`-storage_servers storage_servers...`
 Specifies the list of storage server names for creating a disk pool.

`-stype server_type`
 Specifies the string that identifies the storage server type.

`-U`
 Sets the list type to user readable. This option produces a listing with more fields and one attribute per line.

EXAMPLES

Example 1

Preview all SharedDisk enclosures that the storage servers see and display in short mode.

```
# nbdevconfig -previewenclr -l -hosts daloa -M daloa
V6.5 imported_dg 0 1.20 1.20 3 daloa.min.veritas.com
```

Example 2

Preview all SharedDisk enclosures that the storage servers see and display in user readable mode.

```
# nbdevconfig -previewencldr -U -storage_servers daloa -M daloa
Preview of Enclosure imported_dp as Disk pool
Disk Pool Name   : imported_dp
Disk Pool Id    : imported_dp
Disk Type       : SharedDisk
Availability    : Free
Raw Size (GB)   : 1.20
Usable Size (GB) : 1.20
Num Volumes    : 3
Storage Server  : daloa.min.veritas.com
```

Example 3

Preview all SharedDisk enclosures that the storage servers see.

```
# nbdevconfig -previewencldr -U -enclosure imported_dp
Preview of Enclosure imported_dg as Disk Pool
Disk Pool Name   : imported_dp
Disk Pool Id    : imported_dp
Disk Type       : SharedDisk
Availability    : Free
Raw Size (GB)   : 1.20
Usable Size (GB) : 1.20
Num Volumes    : 3
Storage Server  : daloa.min.veritas.com
```

Example 4

Create a disk pool by specifying an enclosure

```
$ nbdevconfig -importencldr -enclosure emc1 -storage_servers server1
-hwm 95
<Disk pool emc1 has been created successfully>
```

Example 5

Create a disk pool by specifying the list of volumes (in a file)

```
$ nbdevconfig -createdp -dp emc2 --storage_servers server1 -stype
SharedDisk -hwm 95 -dvlist file.txt
<Disk pool emc2 has been created successfully>
```

Example 6

Delete a disk pool.

```
$ nbdevconfig -deletedp -dp Disk-Pool-2
failed to delete disk pool
...[user expires all images on the disk group]...
$ nbdevconfig -deletedp -dp Disk-Pool-2
Disk pool Disk-Pool-2 has been deleted successfully
```

Example 7

Mark a disk pool as DOWN.

```
$ nbdevconfig -changestate -stype SharedDisk -dp diskpool_alpha  
-state DOWN
```

Example 8

Mark a disk volume as UP.

```
$ nbdevconfig -changestate -stype SharedDisk -dp diskpool_alpha -dv  
alpha_voll -state UP
```

Example 9

Inventory a disk group.

```
$ nbdevconfig -inventorydp -preview -stype SharedDisk -dp  
Disk-Pool-2
```

```
Old Raw Size (GB): 97.85  
New Raw Size (GB): 103.45
```

```
Old Formatted Size (GB): 97.80  
New Formatted Size (GB): 103.40
```

```
Old Host List: willow,Apple,dunamo  
New Host List: Dellco,carrot,Apple,dynamo
```

Affected Storage Units

```
-----  
SSO-STU-7 - willow [...] would be removed from media server list  
SSO-STU-9 - willow [...] would be removed from media server list,  
switched to "any available" media server list.
```

Affected Storage Units

```
-----  
SSO-STU-7 -willow [...] was removed from media server list  
SSO-STU-9 -willow [...] was removed from media server list, switched  
to "any available" media server list.
```

SEE ALSO

nbemmcmd

nbdevquery

NAME

nbdevquery - display NetBackup disk media status

SYNOPSIS

```
install_path\NetBackup\bin\nbdevquery -listdp -stype server_type [-dp  
disk_pool_name] [-M master_server] [-l | -U | -D]  
install_path\NetBackup\bin\nbdevquery -liststs [-stype server_type]  
[-storage_server storage_server] [-l | -U | -D]  
install_path\NetBackup\bin\nbdevquery -listdv -stype server_type [-dp  
disk_pool_name [-dv disk_volume_name]] [-M master_server] [-l | -U |  
-D]  
install_path\NetBackup\bin\nbdevquery -listmediaid id... [-l | -U]
```

DESCRIPTION

The `nbdevquery` command line utility is the disk equivalent of `bpmedialist` for tape. The following are the three operations that `nbdevquery` performs:

- `-listdp` lists all disk pools.
- `-liststs` lists all storage servers in the system.
- `-listdv` displays status for disk volumes of imported disk pools. It includes such things as whether the volume is online or offline or the number of current readers (or writers) to the volume.
- `-listmediaid` lists all disk volumes that have been given a disk media id.

OPTIONS

- D
Sets the list type to dump. This option dumps information without further processing.
- dp *disk_pool_name*
Specifies the name of the disk pool to be queried. This pool is the data storage area for this storage unit.
- dv *disk_volume*
Displays the status for only the specified disk volume. For NearStore, the input value is the volume path. For BasicDisk, the input value is the path. In all other cases, the input value is the volume name.

- l
Sets the list type to short. This option produces parsable output with all fields on one line, no headers. The first field indicates the version of the output as an aid to the script operation. Date and time values appear in UNIX long format; status values appear in integer form.
- listdp
Lists all imported disk pools in the NetBackup database. For OpenStorage disk, `-listdp` lists all the disk pools that have been configured.
- listdv
Lists the status for all disk volumes of imported disk pools. This returns a list of all disk volumes in the NetBackup database.
- listmediaid *id...*
Lists all disk volumes that have been given the specified disk media IDs.
- liststs
Lists all servers that host storage. These include appliances such as OpenStorage, SAN-attached storage such as SharedDisk, BasicDisk, and Network-attached storage (NAS devices) such as NetApp.
- storage_server *storage_server*
The host name of the storage server. For NearStore, this name is the hostname of the NearStore system. For BasicDisk, the name of the media server. In all other cases, this option is the name given to the storage server when it was created.
- stype *server_type*
Specifies the string that identifies the storage server type.
- U
Lists the configuration information about the specified disk pool, storage server, or disk storage (see Example 1). Some of the items cannot be changed.

EXAMPLES

Example 1:

```
# nbdevquery -liststs -stype AdvancedDisk -U
Storage Server      : <machine_name>
Storage Server Type : AdvancedDisk
Storage Type       : Formatted Disk, Direct Attached
State              : UP
Flag               : OpenStorage
Flag               : AdminUp
Flag               : InternalUp
Flag               : SpanImages
Flag               : LifeCycle
```

```
Flag           : CapacityMgmt
Flag           : FragmentImages
Flag           : Cpr
Flag           : RandomWrites
Flag           : FT-Transfer
```

Example 2:

List all disk pools in the system.

```
# nbdevquery -styp SharedDisk -dp disk-pool-1
V6.5 Disk-Pool-1 0 97456 97480 10 80 90 server1,server2,server3
```

Example 3:

Use all disk pool information in user format.

```
# nbdevquery -styp SharedDisk -dp disk-pool-1 -U
Disk pool name: disk-pool-1
Disk type: SharedDisk
Raw Size: 97456
Usable Size: 97456
Num Volumes: 10
Low watermark: 85%
High watermark: 95%
Comments: xxx
Media Server: server1
Media Server: server2
Media Server: server3
```

Example 4:

```
# nbdevquery -listdp -dp sim_dp1 -styp SharedDisk -D
Disk Drive Dump
  name           : <sim_dgl>
  id             : <sim_dgl>
  server_type    : <SharedDisk>
  master_server  : <daloa.min.veritas.com>
  access_media_server : <>
  disk_storage_type : 6
  total_capacity : 1286602752
  used_space     : 0
  sts_state      : 0
  availability    : 2
  connectivity    : 0
  high_watermark : 98
  low_watermark  : 80
  num_diskvolumes : 3
  num_disks      : 0
  num_stservers  : 2
  system_tag     : <Imported from STS>
  user_tag       : <>
Storage Server [0]
```

```
name : <daloa.min.veritas.com>
id   : <>
server_type      : <SharedDisk>
storage_type     : 6
access_media_serv.: <>
Storage Server [1]
name            : <blackjack.min.veritas.com>
id             : <>
server_type     : <SharedDisk>
storage_type    : 6
access_media_serv.: <>
```

SEE ALSO

nbenmcmd

nbemm

NAME

`nbemm` - run the NetBackup EMM daemon to manage volumes, volume pools, barcode rules, and devices

SYNOPSIS

```
install_path\NetBackup\bin\nbemm [-console] [-terminate]
```

DESCRIPTION

The Enterprise Media Manager daemon or service manages volumes, volume pools, barcode rules, and devices. This daemon performs media, drive, drive path, and storage unit selection. In addition, `nbemm` acts as the device allocator (DA) for SharedDisk environments. In this case, `nbemm` is known as `nbemm/DA`. For more information about `nbemm/DA`, refer to the *NetBackup Administrator's Guide*.

Note: The `nbemm` daemon or service must be active to change the volume configuration, device configuration, storage unit configuration, and for any tape mount activity.

To start `nbemm`, enter `nbemm`.

To stop `nbemm`, enter `nbemm -terminate`.

OPTIONS

`-console`

This option enables you to start NetBackup in console mode.

`-terminate`

This option enables you to stop the `nbemm` binary.

SEE ALSO

`nbemmcmd`

nbemmcmd

NAME

nbemmcmd - update and view information in the EMM database

SYNOPSIS

```
install_path\NetBackup\bin\admincmd\nbemmcmd [-addhost] [-changesetting]
[-deletheost] [-delete_media] [-delete_merge] [-errorsdb]
[-forcemerge] [-getemmserver] [-help] [-listhosts] [-listmedia]
[-listsettings] [-machinealias] [-renamehost] [-servercontrol]
[-setemmserver] [-updatehost]
```

This section contains the usage statements for each of the options.

```
install_path\NetBackup\bin\admincmd\nbemmcmd -addhost [-activenodename
string] [-brief] [-clustername string] [-displayname string]
[-machinedescription string] -machinename string -machinetype api |
app_cluster | cluster | master | media | ndmp [-masterserver string]
[-netbackupversion level[.major_level[minor_level]]] [-operatingsystem
hpux | linux | rs6000 | sgi | solaris | tru64 | windows] [-scanability
unsigned_integer]
```

```
install_path\NetBackup\bin\admincmd\nbemmcmd -changesetting
[-ALLOW_MULTIPLE_RETENTIONS_PER_MEDIA 0|1|no|yes]
[-DISABLE_AUTOMATIC_HOST_NAME_ADD 0|1|no|yes]
[-DISABLE_BACKUPS_SPANNING_DISK 0|1|no|yes]
[-DISABLE_DISK_STU_JOB_THROTTLING 0|1|no|yes]
[-DISABLE_STANDALONE_DRIVE_EXTENSIONS 0|1|no|yes]
[-DISALLOW_NONNDMP_ON_NDMP_DRIVE 0|1|no|yes] [-DO_NOT_EJECT_STANDALONE
0|1|no|yes]
[-DONT_USE_SLAVE 0|1|no|yes]
[-DRIVE_ERROR_THRESHOLD unsigned_integer]
[-DRIVE_NAME_SEED 0|1|no|yes] [-emname string]
[-emmport unsigned_integer] -machinename string
[-MAX_REALLOC_TRIES unsigned_integer] [-MEDIA_ERROR_THRESHOLD
unsigned_integer] [-MEDIA_REQUEST_DELAY unsigned_integer]
[-MPMS_DISABLE_EVENTS 0|1|no|yes]
[-MPMS_DISABLE_RANK unsigned_integer]
[-MUST_USE_LOCAL_DRIVE 0|1|no|yes]
[-NBUFS_DESTINATION_DSU string]
[-NBUFS_DUP_TSU_TO_DSU 0|1|no|yes]
[-NBUFS_RETENTION_LEVEL unsigned_integer]
[-NON_ROBOTIC_MEDIA_ID_PREFIX string]
[-PREFER_NDMP_PATH_FOR_RESTORE 0|1|no|yes]
[-RETURN_UNASSIGNED_MEDIA_TO_SCRATCH_POOL 0|1|no|yes]
[-SCSI_PROTECTION NONE | SPR | SR]
```

```
[-SHAREDISK_MOUNT_POINT string]  
[-TIME_WINDOW unsigned_integer]  
[-UNRESTRICTED_SHARING 0|1|no|yes]  
[-VALIDATE_HOST_NAME 0|1|no|yes]  
[-VAULT_CLEAR_MEDIA_DESC 0|1|no|yes]  
  
install_path\NetBackup\bin\admincmd\nbemmcmd -deletehost [-brief]  
-machinename string -machinetype api | app_cluster | cluster | master |  
media | ndmp | master | media | ndmp-mediaid string  
  
install_path\NetBackup\bin\admincmd\nbemmcmd -deletemedia -mediaid string  
-originhost string  
  
install_path\NetBackup\bin\admincmd\nbemmcmd -deletemerge -assignedhost  
string -mediaid string  
  
install_path\NetBackup\bin\admincmd\nbemmcmd -errorsdb [-brief] [-prune  
[-days no_of_days] [-hours no_of_hours] [-minutes no_of_minutes]]  
  
install_path\NetBackup\bin\admincmd\nbemmcmd -forcemerge -assignedhost  
string -mediaid string -originhost string  
  
install_path\NetBackup\bin\admincmd\nbemmcmd -getemmserver [-masterserver  
string] [-timeout unsigned_integer]  
  
install_path\NetBackup\bin\admincmd\nbemmcmd -listhosts [-brief]  
[-verbose] [-parsable] [-list_snap_vault_filers -machinename string]  
[-list_snap_vault_media_servers -masterserver string]  
[-list_sts_hosts -machinename string]  
[-list_sts_media_servers -masterserver string]  
[-list_app_clusters -masterserver string]  
[-servers_in_emm_cluster -clustername string]  
[-servers_in_app_cluster -clustername string]  
[-nbservers [-masterserver string]]  
[-display_server -machinename string -machinetype string]  
[-netbackupversion level[.major_level[minor_level]]]  
  
install_path\NetBackup\bin\admincmd\nbemmcmd -listmedia [-allrecords]  
[-conflicts] [-mediaid string] [-mediatype unsigned_integer]  
[-mergetable] [-poolname string] [-robotnumber unsigned_integer]  
[-vaultcontainer string]  
  
install_path\NetBackup\bin\admincmd\nbemmcmd -listsettings -machinename  
string  
  
install_path\NetBackup\bin\admincmd\nbemmcmd -machinealias machinealias  
[-addalias] -alias string -machinename string] [-deletealias -alias  
string] [-deleteallaliases -machinename string] [-getaliases  
-machinename string] -machinetype api | app_cluster | cluster | master  
| media | ndmp  
  
install_path\NetBackup\bin\admincmd\nbemmcmd -releasecache [-brief]  
[-emmname string] [-emmport unsigned_integer] -machinename string
```

```
install_path\NetBackup\bin\admincmd\nbemmcmd -renamehost [-brief]
  -machinename string -machinetype api | app_cluster | cluster | master |
  media | ndmp -newmachinename string

install_path\NetBackup\bin\admincmd\nbemmcmd -servercontrol [-brief]
  [-resume] [-suspend]

install_path\NetBackup\bin\admincmd\nbemmcmd -setemmserver [-brief]
  -emmservername string [-masterserver string] -newemmservername string
  [-timeout unsigned_integer]

install_path\NetBackup\bin\admincmd\usr/openv/netbackup/bin/admincmd/nbe
  mmcmd nbemmcmd -updatehost [-activenodename string]
  [-add_server_to_app_cluster] [-brief] [-clustername string]
  [-delete_server_from_app_cluster] [-displayname string]
  [-machinedescription string] -machinename string [-machinestateop
  clr_admin_pause | clr_admin_pause_and_set_active | clr_disk_active |
  clr_ltid_restart | clr_master_server_connectivity | clr_tape_active |
  reset_all | set_admin_pause | set_disk_active |
  set_master_server_connectivity | set_tape_active] [-machinetype pi |
  app_cluster | cluster | master | media | ndmp] [-masterserver string]
  [-netbackupversion level [.major_level[minor_level]]] [-operatingsystem
  hpux | linux | rs6000 | sgi | solaris | tru64 | windows]
```

DESCRIPTION

The `nbemmcmd` command enables users to update a limited set of EMM database information. In addition, this command enables you to manage host entries, configuration options, and other miscellaneous items in the EMM database.

OPTIONS

The following commands contain a variety of options that enable you to manage the EMM database. The names of the options are purposely long to provide the user with a better understanding of how the options are to be used. Because of the option name length, you need only type the first letter or letters of the command that make it a unique option. For example, to use the `-changesetting` option, you can type `-c` because no other command option starts with the letter `c`.

`-addhost`

This option adds the specified host to the EMM database. The following entries can be adjusted by using this command option:

`-activenodename string`

Identifies the active node in a cluster.

`-brief`

Makes the output of the command less verbose.

`-clustername string`

Identifies the cluster to which this machine belongs.

`-displayname string`

Sets the display name of the machine.

`-machinedescription string`

Describes the machine or system being used.

`-machinename string`

Specifies the name of the machine to be updated.

`-machinetype api | app_cluster | cluster | master | media | ndmp`

Defines how the machine is used.

`-masterserver string`

Defines the host master server n a particular domain.

`-netbackupversion level[.major_level[minor_level]]`

Specifies the version that the added host is running. The *level* variable has a range of 0-99. The *major_level* and *minor_level* variables are optional single-digit fields. No spaces are allowed between the *major_level* and *minor_level* variables.

For example, enter the following information to specify NetBackup 6.0:

`-netbackupversion 6.0` or `-netbackupversion 6`

`-operatingsystem hpux | linux | rs6000 | sgi | solaris | tru64 | windows`

Adds a host with a designated operating system.

`-scanability unsigned_integer`

This option applies only to NetBackup Enterprise Servers that use the Shared Storage Option (SSO) feature.

A scan ability factor can range from zero to 9, with a default value of 5. This factor allows the assignment of scan hosts to be prioritized if a drive's scan host changes. Scan hosts with higher scan ability factors are chosen first.

Some SharedDisk configurations contain undesirable servers for use as the scan host for a drive. They have limited resources, are behind firewalls, or people other than NetBackup administrators administer them. These servers can be configured so they never become the scan host for any drive. A scan_factor of zero means that a server cannot become the scan host.

Caution: A drive is unavailable for use until a scan host can be assigned to it. If all hosts that register for a particular drive use `scan_factor = 0`, the drive remains unusable. They are unusable until a host with a non-zero `scan_factor` registers for the drive. If all hosts with a non-zero `scan_factor` have the drive DOWN, then again the drive becomes unavailable due to the lack of a scan host.

The decision to use a `scan_factor` of zero for a server reduces the level of resiliency in your SSO configuration. Be aware of the servers that can be a scan host for a drive. If a drive loses a scan host, it makes the drive unavailable to any server.

`-changesetting`

Changes the configuration setting for a specified host. Also adds the settings that did not previously exist. The following options can be changed by using the `-changesetting` command along with each of these options. The following descriptions are brief. These settings are described in detail in the *NetBackup Administrator's Guide*.

`-ALLOW_MULTIPLE_RETENTIONS_PER_MEDIA 0|1|no|yes`

Allows NetBackup to mix retention levels on media. Default: Each volume can contain backups of only a single retention level.

`-DISABLE_AUTOMATIC_HOST_NAME_ADD 0|1|no|yes`

Disables the ability of EMM to add a host name automatically if it appears to be valid. An example of an invalid host name is a name that duplicates another host.

`-DISABLE_BACKUPS_SPANNING_DISK 0|1|no|yes`

Disables the ability of a backup operation to disk to continue when a file system full condition occurs on a disk storage unit volume. It disables by using image fragments on multiple storage unit volumes.

`-DISABLE_DISK_STU_JOB_THROTTLING 0|1|no|yes`

Disables the disk storage unit job throttle action that occurs when disk storage units approach their high-water mark. Disk storage unit throttling limits the number of jobs that are started simultaneously in order to approach the high-water mark more accurately. Default: Throttle disk storage units that approach their high-water mark.

`-DISABLE_STANDALONE_DRIVE_EXTENSIONS 0|1|no|yes`

Disables non-robotic drive operations. During a backup, NetBackup does not automatically attempt to use whatever labeled or unlabeled media it finds in a non-robotic drive. Default: stand-alone drive extensions are enabled.

`-DISALLOW_NONNDMP_ON_NDMP_DRIVE 0|1|no|yes`

The MDS logic on the EMM server reads this option. NetBackup attempts to use an available drive that is based on the type of request as follows:

For a non-NDMP request of any kind, NetBackup tries to find an available non-NDMP drive. If a non-NDMP drive is not available and an NDMP drive is available, the slower NDMP drive is used. Non-NDMP requests include all type of requests apart from storage unit related requests (backups and write side of duplicates) and NDMP image restores.

`-DO_NOT_EJECT_STANDALONE 0|1|no|yes`

If this entry is enabled, tapes in stand-alone drives are not ejected when a backup has completed on that host. (Tapes are ejected if end-of-media is reached during a backup.) Use this option in a NetBackup environment where you want to keep a stand-alone drive ready after successful backups are performed.

`-DONT_USE_SLAVE 0|1|no|yes`

De-selects the use of drive name rules to assign names to drives automatically.

`-DRIVE_ERROR_THRESHOLD unsigned_integer`

Changes the threshold or number of drive errors that can occur before NetBackup changes the drive state to DOWN. Default: 2.

`-DRIVE_NAME_SEED 0|1|no|yes`

Selects the use of drive name rules to assign names to drives automatically.

`-emmname string`

Specifies the name of the EMM database server. This server contains the database that stores the media and device configuration information.

`-emmport unsigned_integer`

Specifies the EMM port.

`-machinename string`

Names the machine whose settings are changed.

`-MAX_REALLOC_TRIES unsigned_integer`

Specifies the maximum number of attempts that NetBackup makes to reallocate the media for future backups.

`-MEDIA_ERROR_THRESHOLD unsigned_integer`

Changes the threshold or number of media errors that can occur before the media is frozen. Default: 2.

`-MEDIA_REQUEST_DELAY unsigned_integer`

Specifies the number of seconds that NetBackup waits for a drive to become ready. Applies only to non-robotic drives. Default: 0 seconds. For example, assume that the delay is 150 seconds:

`MEDIA_REQUEST_DELAY = 150`

Add this information to the `bp.conf` file on NetBackup servers or enter a value for Media Request Delay in the Media host properties.

`-MPMS_DISABLE_EVENTS 0|1|no|yes`

`-MPMS_DISABLE_RANK 0|1|no|yes`

`-MUST_USE_LOCAL_DRIVE 0|1|no|yes`

If the client is also a master server and this option is active, backups for this client must occur on a local drive. If the client is not a master server, this entry has no effect.

Add this option to the `bp.conf` file on NetBackup master servers. Or check the Must Use Local Drive setting in the General Server host properties dialog box.

`-NBUFS_DESTINATION_DSU string`

`-NBUFS_DUP_TSU_TO_DSU 0|1|no|yes`

`-NBUFS_RETENTION_LEVEL unsigned_integer`

`-NON_ROBOTIC_MEDIA_ID_PREFIX string`

Specifies the media ID prefix used for creating non-robotic media. It applies to the host that the `-machinename` option specifies. The media ID prefix is a one to three alphanumeric string of characters.

`-PREFER_NDMP_PATH_FOR_RESTORE 0|1|no|yes`

`-RETURN_UNASSIGNED_MEDIA_TO_SCRATCH_POOL 0|1|no|yes`

This option is an EMM global option that applies to every host that uses the EMM server. It is not a host option.

Option is set to YES: The Media Manager returns expired and unassigned media (media that was originally from the same scratch pool) to the scratch volume pool automatically.

Option is set to NO: The automatic behavior of returning media to the scratch pool is disabled. Media must be moved by using one of the Media Manager administration interfaces.

`-SCSI_PROTECTION NONE | SPR | SR`

Allows exclusive access protection for tape drives. With access protection, other host bus adaptors cannot issue commands to control the drives during the reservation. The three possible settings for this option are:

NONE - No protection

SPR - SCSI persistent reserve

SR - SPC-2 SCSI reserve (default condition)

`-SHAREDDISK_MOUNT_POINT` *string*

A scan ability factor can range from zero to 9, with a default value of 5. This factor allows the assignment of scan hosts to be prioritized if a drive's scan host changes. Scan hosts with higher scan ability factors are chosen first.

If you back up a media server that uses mount points to any disk storage that contains backup images, do not cross mount points.

See the Policies chapter of the *NetBackup Administrator's Guide* for more information on the **Cross mount points** attribute.

`-TIME_WINDOW` *unsigned_integer*

Enables you to set a value that is equal to the amount of time in which errors can be tracked. You can use this value with an error threshold (for example, `media_error_threshold`) to monitor the number of media errors that occur within the time window. The default setting is 12 hours.

`-UNRESTRICTED_SHARING` 0|1|no|yes

Enables unrestricted media sharing for all media servers.

`-VALIDATE_HOST_NAME` 0|1|no|yes

Enables host name character validation according to NetBackup standard. If this option is disabled, you can use a name like “_host1”, for example, that does not follow the standard.

`-VAULT_CLEAR_MEDIA_DESC` 0|1|no|yes

This option is an EMM global option that applies to every host that uses the EMM server. It is not a host option. When NetBackup media is returned from the off-site vault during a typical tape rotation, it is expired and is ready for reuse by new backups. To avoid confusion, it may be helpful to clear the old media description information when an expired tape is returned to the robot. If this entry is specified, the media description field is cleared when other Vault information is cleared from the Media Manager volume database.

`-deletehost`

Deletes an EMM machine record by using the required machine name and machine type.

`-brief`

Generates a less verbose output of the command.

`-machinename` *string*

Removes the specified host from the EMM database.

`-Machinetype` *api* | *app_cluster* | *cluster* | *master* | *media* | *ndmp*

Identifies by type the machine to be removed.

`-deletemedia`

Deletes an EMM media record with the specified media ID and origin host.

`-mediaid string`

Specifies the media ID of the EMM media record.

`-originhost string`

Specifies the origin host name in the EMM media record. It indicates from which Volume Database host this EMM media record originated.

`-deletemerge`

Deletes a record from the media DB merge table with the specified media ID and assigned host.

When you use optical media, run `deletemerge` twice, once for each side of the platter.

The `deletemerge` option only exists for the life of the NetBackup 6.5 release. All mediaDB merge table issues must be resolved before the next release of NetBackup is installed. At that time, this option is removed from NetBackup and the contents of the mediaDB merge table is deleted.

`-assignedhost string`

Specifies the host name in the mediaDB merge table record. It indicates which media server assigned this media.

`-mediaid string`

Specifies the media id of the record to delete from the mediaDB merge table.

`-errorsdb`

`-brief`

Generates a less verbose output of the command.

`-prune [-days no_of_days] [-hours no_of_hours] [-minutes no_of_minutes]`

Removes the entries from the error database. The optional days, hours, and minutes arguments determine which database entries to delete. It removes any entries older than the specified time.

`-forcemerge`

Moves the contents of a specified record in the mediaDB merge table (media ID and assigned host) to the specified EMM media record (media ID and origin host). First, a new record is created in the media DB merge table. Then the existing media DB fields in the EMM media record are moved there.

The `forcemerge` option exists only for the life of the NetBackup 6.5 release. All mediaDB merge table issues must be resolved before the next release of NetBackup is installed. At that time, this option is removed from NetBackup and the contents of the mediaDB merge table are deleted.

`-assignedhost string`

Specifies the host name in the mediaDB merge table record. It indicates which media server assigned this media.

`-mediaid string`

Specifies the media ID of the record in the mediaDB merge table to match to an EMM media record.

`-originhost string`

This name is the origin host name in the EMM media record. It indicates the Volume Database host that is the origin of this EMM media record.

`-getemmserver`

Displays the information on all the hosts in a particular EMM domain. Use this command to ensure a level of consistency in a newly installed domain or modified domain.

`-brief`

Generates a less verbose output of the command.

`-masterserver string`

Specifies a name of a master server for an EMM domain. If you omit this option when you use this command, the current machine is assumed.

`-timeout unsigned integer`

Specifies a temporary timeout value in seconds to be used during the duration of this command.

`-help`

This option provides usage information and detailed help for the `nbemmcmd` command by entering the following:

```
nbemmcmd -help command
```

The *command* variable is the command for which you want help.

`-listhosts`

This option dumps the table structure for each known host.

`-display_server -machinename string -machinetype string`

Displays only the specified machine by the machine name and machine type.

`-list_app_clusters -masterserver string`

Lists all of the application clusters of the specified master server.

`-list_snap_vault_filers -machinename string`

Lists all of the SnapVault filers of the specified machine name (see `-machinename` option description that follows).

`-list_snap_vault_media_servers -masterserver string`

Lists all of the SnapVault media servers of the specified master server.

`-list_sts_hosts -machinename string`

Lists all OpenStorage hosts connected to the specified machine name.

`-list_sts_media_servers -masterserver string`

Lists all OpenStorage media servers connected to the specified master server.

`-machinename api | app_cluster | cluster | master | media | ndmp`

Defines the type of machine to list.

`-nbservers -masterserver string`

Displays only the media servers and master servers. The default for `-listhosts` is to display all servers.

`-netbackupversion level[.major_level[minor_level]]`

Specifies the version of the machine. The level variable has a range of 0-99. The *major_level* and *minor_level* variables are optional single-digit fields. There should be no spaces between the *major_level* and *minor_level* variables.

For example, enter the following information to specify NetBackup 6.0:

`-netbackupversion 6.0` or `-netbackupversion 6`

`-servers_in_emm_cluster -clustername string`

Lists all servers in the specified cluster.

`-server_in_app_cluster -clustername string`

Lists all of the application cluster servers of the specified cluster.

`-brief`

Makes the output of the command less verbose.

`-parsable`

Makes the output of the command parsable.

`-verbose`

Controls how host information is displayed. Multiple lines of output are printed, one for each parameter of a host.

`-listmedia`

`-allrecords`

Displays all media records.

`-conflicts`

Displays all media records whose conflicts field has been set.

`-mediaid string`

Specifies the media ID of the EMM media record.

`-mediatype unsigned integer`

Queries the volumes by media type.

Valid media types for NetBackup Enterprise Server are:

4mm, 8mm, 8mm2, 8mm3, dlt, dlt2, dlt3, dtf, hcart, hcart2, hcart3, odiskwm, odiskwo, qcart, 4mm_clean, 8mm_clean, 8mm2_clean, 8mm3_clean, dlt_clean, dlt2_clean, dlt3_clean, dtf_clean, hcart_clean, hcart2_clean, hcart3_clean.

Valid media types for NetBackup Server are:

4mm, 8mm, dlt, hcart, qcart, 4mm_clean, 8mm_clean, dlt_clean, hcart_clean.

`-mergetable`

Displays all the records in the mediaDB merge table that cannot be matched to an EMM media record. The mergetable option exists only for the life of the NetBackup 6.5 release. All mediaDB merge table issues must be resolved before the next release of NetBackup is installed. At that time, this nbemmcmd option is removed from NetBackup and the contents of the mediaDB merge table is deleted.

`-poolname string`

Queries the volumes by pool number, an index into the volume pool. Use `vmpool -listall` to determine the index for a given pool name.

`-robotnumber unsigned_integer`

Queries the volumes by robot number. A robot number is a unique, logical identification number for the robot where the volume is located.

`-vaultcontainer string`

Lists the volumes that are stored in the container. The *string* variable is the `vault_container_id`, which can be a string of up to 29 alphanumeric characters.

`-listsettings`

`-machinename string`

Specifies which machine to list settings for.

`-machinealias`

The following parameters are used to maintain the alias list for a particular machine. Use them to view current aliases, add new aliases, and delete current aliases for an identified machine.

`-addalias -alias alias -machinename name -machinetype type`

Adds an alias name to a machine. The proper use of this command requires that you identify the machine name that is to receive the alias as well as the machine type.

For example, to create a media server with the alias name *blue*, use the following command:

```
machinealias -machinename 10.80.91.83 -machinetype media
             -addalias -alias blue
```

```
-deletealias -alias name -machinetype type
```

Deletes an alias name from the database. This operation requires that you identify the alias to be deleted by using the `-alias string` command and machine type with this option.

```
-deleteallaliases -alias name -machinetype type
```

Deletes all aliases for a particular machine. To perform this operation you must identify the machine name and the machine type.

```
-getaliases
```

Retrieves all aliases for a particular machine. To perform this operation you must identify the machine name and the machine type.

```
-alias string
```

Specifies the string that identifies the alias name of a machine.

```
-machinename string
```

Specifies the name of a machine.

```
-Machinetype api | app_cluster | cluster | master | media | ndmp
```

Defines what the machine is used as.

```
-renamehost
```

This command, with the required machine name and new machine name options, renames the current machine name to a new machine name.

```
-machinename string
```

Defines the current machine name.

```
-newmachinename string
```

Defines the new machine name.

```
-servercontrol
```

This option suspends and resumes control of a specified server. You can perform database maintenance without the corruption of existing data because a job began to run during this time.

```
-resume
```

Resumes the control of a specified server.

```
-suspend
```

Suspends the control of a specified server.

```
-setemmserver
```

This command can be used to change the EMM server name for certain hosts in the domain. The EMM server name is changed for each host in the domain whose EMM server name matches the old EMM server name. This command has the following options:

`-emmservername string`

Specifies the EMM server name to be changed.

`-newemmservername string`

Specifies the new, or replacement, value for the EMM server.

`-masterserver string`

Specifies a name of a master server for an EMM domain. If you omit this option when you use this command, the current machine is assumed.

`-timeout unsigned integer`

This option specifies a temporary timeout value in seconds to use for the duration of this command.

`-updatehost -machinename string`

This command, when used with the following options, enables you to make changes to a machine record that was specified by using the required `-machinename` option.

`-add_server_to_app_cluster`

This option designates that the machine should be added to the application cluster that is specified in the `-clustername` option.

`-activenodename string`

Identifies the active node in a cluster.

`-clustername string`

Identifies a cluster to which this machine belongs.

`-delete_server_from_app_cluster`

Designates that the machine should be removed from the application cluster that is specified in the `-clustername` option.

`-displayname string`

Displays the assigned name of a machine that is equivalent to the numbered identifier for that machine.

`-machinename string`

Specifies the machine name to update.

`-machinestateop clr_admin_pause | clr_admin_pause_and_set_active
| clr_disk_active | clr_ltid_restart |
clr_master_server_connectivity | clr_tape_active |
reset_all | set_admin_pause | set_disk_active |
set_master_server_connectivity | set_tape_active`

Sets or clears the specified machine state.

`-Machinetype api | app_cluster | cluster | master | media | ndmp`

Defines what the machine is used as.

`-masterserver string`

Defines the host's master server in the domain.

`-netbackupversion level[.major_level[minor_level]]`

Adds a host and specifies the version it is running. The *level* variable as a range of 0-99. The *major level* and *minor level* variables are optional single-digit fields. There should be no spaces between the *major level* and *minor level* variables.

For example, enter the following information to specify NetBackup 6.5:

`-netbackupversion 6.5`

`-operatingsystem hpux | linux | rs6000 | sgi | solaris | tru64 | windows`

This option enables you to update the operating system of the machine.

EXAMPLES

Example 1

nbemmcmd -getemmserver

These hosts were found in this domain: throttle, upwords

Checking with host: throttle...

Checking with host: upwords...

Server Type	Host	Version	Host Name
EMM Server			
MEDIA		UNKNOWN RELEASE (0)	throttle
throttle			
MASTER	6.0Alpha		upwords
upwords			

One or more hosts had mismatched EMM Servers.

Run-time failure: The consistency check either failed or was incomplete. Command did not complete successfully.

Example 2

nbemmcmd -setemmserver -emmservername throttle -newemm upwords

These hosts were found in this domain: throttle, upwords

Checking with host: throttle...

Checking with host: upwords...

Server Type	Host	Version	Host Name
EMM Server			
MEDIA		UNKNOWN RELEASE (0)	throttle
throttle			throttle
EMM server name was changed.			
MASTER	6.0Alpha		upwords
upwords			

One media hosts had EMM Server name changed. Command was completed successfully.

nbexecute

NAME

`nbexecute`—execute the LiveUpdate policy

SYNOPSIS

```
install_path\NetBackup\bin\nbexecute -LiveUpdate nbmtrans.exe path  
[arguments] -policy policy_name [-schedule schedule_name] -client  
client_name | all [-retryable] [-noretries]
```

DESCRIPTION

The NetBackup master server initiates the NetBackup LiveUpdate policy. The `nbexecute` command submits the request to PEM.

OPTIONS

`nbmtrans.exe path arguments`

Specifies the path arguments and command arguments for the `nbmtrans.exe` command.

`-policy`

Specifies the policy for the LiveUpdate job to be run.

`-schedule`

Specifies the job schedule for the LiveUpdate job to be run.

`-client client_name | all`

Specifies a client *client_name* on which NetBackup runs a job policy. If no client is specified, NetBackup launches a LiveUpdate job for each client in the list.

`-retryable`

Specifies that NetBackup resubmits a failed job.

`-noretries`

Specifies that NetBackup does not attempt to retry job submission if the job fails.

EXAMPLES

The following example on Windows runs LiveUpdate_policy on the `foo_computer` client:

```
nbexecute.exe -LiveUpdate nbmtrans.exe "C:\Program  
Files\VERITAS\NetBackup\bin\nbmtrans.exe" -policy LiveUpdate_policy  
-client foo_computer
```

nbfirescan

NAME

nbfirescan—scan for SCSI disk devices and print out report

SYNOPSIS

install_path\NetBackup\bin\admincmd\firescan

DESCRIPTION

The nbfirescan (Frozen Image Rescan) utility scans for SCSI disk devices and prints what it finds. It is available on all media servers and is used to triage import problems.

Only authorized users can run this command.

For more information about NetBackup authorization, refer to the *NetBackup Security and Encryption Guide*.

EXAMPLES

Example 1

The following is a sample Windows output from the local host SCSI bus scan:

```
C:\Program Files\Common Files\Symantec Shared\VxFI\4\Bin>
nbfirescan.exe
```

```
nbfirescan v4.4.1 - Copyright (c) 2005-2007 Symantec Corp.
Rescanning
devices.....Complete.
Device count: 48
DevicePath          Vendor    Product ID          EnclosureId
DeviceId            [Ctl, Bus, Tgt, Lun]
-----
\\.\PHYSICALDRIVE0 SEAGATE  ST336607LW  -          -
[00,02,00,00]
\\.\PHYSICALDRIVE1 SEAGATE  ST336607LW  -          -
[00,02,01,00]
\\.\PHYSICALDRIVE2 COMPAQ   HSV111 (C)COMPAQ  5000-1FE1-5004-5660
6005-08B4-0010-120F-0000-7000-0956-0000  [00,04,00,01]
\\.\PHYSICALDRIVE3 COMPAQ   HSV111 (C)COMPAQ  5000-1FE1-5004-5660
6005-08B4-0010-4E39-0000-4000-0010-0000  [00,04,00,02]
```

nbftconfig

NAME

`nbftconfig`—configure attributes associated with fibre transport (FT) servers and SAN clients

SYNOPSIS

```
install_path\NetBackup\bin\admincmd\nbftconfig [-addclient]
  [-deleteclient] [-changeclient] [-rescanclient] [-listclients]
  [-addserver] [-deleteserver] [-changeserver] [-listservers]
  [-listactive] [-setconfig] [-getconfig] [verbose] [-help]

install_path\NetBackup\bin\admincmd\nbftconfig [-ac]addclient -C
  client_name [-M master_server] [-ftpref preferred | always | never]
  [-ftwait minutes] [-ftrwait minutes]

install_path\NetBackup\bin\admincmd\nbftconfig [-dc]deleteclient
  client_name

install_path\NetBackup\bin\admincmd\nbftconfig [-cc]changeclient -C
  client_name {-ftpref preferred | always | never} [-ftwait minutes]
  [-ftrwait minutes] | -np number_of_ports}

install_path\NetBackup\bin\admincmd\nbftconfig [-rc]rescanclient -C
  client_name

install_path\NetBackup\bin\admincmd\nbftconfig [-lc]listclients
  [-verbose] [-C client_name | -Me media_server | -M master_server]

install_path\NetBackup\bin\admincmd\nbftconfig [-as]addserver -Me
  media_server [-M master_server] [-l connection_limit] [-state active |
  disabled]

install_path\NetBackup\bin\admincmd\nbftconfig [-ds]deleteserver
  media_server

install_path\NetBackup\bin\admincmd\nbftconfig [-cs]changeserver -Me
  media_server [-l connection_limit] [-state active | disabled]

install_path\NetBackup\bin\admincmd\nbftconfig [-ls]listservers [-Me
  media_server | -M master_server] [-verbose]

install_path\NetBackup\bin\admincmd\nbftconfig [-la]listactive [-C
  -client_name | -Me media_server] [verbose]

install_path\NetBackup\bin\admincmd\nbftconfig -setconfig [-M
  master_server] {-ftpref preferred | always | never [-ftwait minutes]
  [-ftrwait minutes] | -np number_of_ports}
```

```
install_path\NetBackup\bin\admincmd\nbftconfig -getconfig [-M  
master_server] [-verbose]  
install_path\NetBackup\bin\admincmd\nbftconfig -option -help
```

DESCRIPTION

`nbftconfig` is a NetBackup utility that modifies the attributes that are associated with the Fibre Transport (FT) server. It also creates the SAN client entities in the EMM database.

The operations that are available by using the `nbftconfig` CLI are:

- Add a new SAN client and its attributes to the EMM database
- Modify an existing SAN client record
- Delete a SAN client
- Add a new FT server
- Modify the attributes of an existing FT server record
- List SAN clients that are defined within the database
- List FT servers that are defined within the database
- List by all active fibre channel connections

OPTIONS

`-addclient`

Adds the specified SAN client to the EMM database. SAN clients are normally automatically discovered when the SAN client code is installed on the client. However, if the notification from the client to the EMM server is lost, use this command to manually add the client. The following attributes can be set by using this command option:

`-C client_name`

The name of the SAN client that is to be added to the database.

`-M master_server`

Specifies the master server that is associated with the designated client. If this option is omitted, the local client's master server is used.

`-ftpref preferred | always | never`

Determines if the fibre connections to the media server are preferred, must always be used, or should never be used. If preferences are not provided, master server defaults are used. This value is set by default according to the global defined for the EMM server.

`-ftwait minutes`

Defines the number of minutes that a backup job should wait for an available fibre channel connection before it uses a standard network connection. This option is valid only when the `ftpref` type is set to `preferred`.

`-ftrwait minutes`

Defines the number of minutes that a restore job should wait for an available fibre channel connection before it uses a standard network connection. This option is only valid when the `ftpref` type is set to `preferred`.

`-np number_of_ports`

Defines the maximum number of client ports that can be simultaneously used on a single media server. If the maximum number of client ports is set to 0, then all ports will be used. The default number of client ports is 2.

`-deleteclient`

Deletes the specified client from the EMM database. The following attribute may be included with this option.

`client_name`

Specifies the name of the SAN client that is to be deleted from the database.

`-changeclient`

Changes the options that are associated with a specific SAN. The following attributes can be set by using this command option:

`-C client_name`

The name of the SAN client that is to be added to the database.

`-ftpref preferred | always | never`

Determines if the fibre connections to the media server are preferred, must always be used, or should never be used. If preferences are not provided, master server defaults are used. This value is set by default according to the global defined for the EMM server.

`-ftwait minutes`

Defines the number of minutes that a backup job should wait for an available fibre channel connection before it uses a standard network connection. This option is valid only when the `ftpref` type is set to `preferred`.

`-ftrwait minutes`

Defines the number of minutes that a restore job should wait for an available fibre channel connection before it uses a standard network connection. This option is only valid when the `ftpref` type is set to `preferred`.

-rescanclient

This operation scans the client for new FT devices. The following attributes can be set by using this command option:

-C *client_name*

The name of the SAN client to scan.

-listclients

Displays the list of SAN clients and attributes associated with the clients. By default all SAN clients are listed with a subset of attributes. The information output by the `listclients` operation depends on whether all clients are listed or the attributes associated with a specific SAN client.

The following attributes can be set by using this command option:

-C *client_name*

Specifies the name of the SAN client whose information you want listed. If this attribute is omitted, `listclients` lists the information for all clients that are attached to the designated media server or master server.

-Me *media_server*

Specifies the name of the FT server for whose attached clients you want the information listed.

-M *master_server*

Specifies the master server that is associated with the FT servers. If this option is omitted, all FT servers are returned.

-verbose

The output can be displayed in verbose mode and non-verbose mode (by default). When all clients are listed (including all clients by master or media server), the following information appears (multi-client output):

Verbose mode output:**Client Record**

SAN client name

Version – Client NBU software version

State – SAN client state

Master server name

Number of FT servers to which the SAN client can connect

Usage preferences (see `addclient`)

Usage preference wait period (See `addclient`)

If a specific SAN client is included in the `listclients` command, then the following information is displayed for that client (single client output):

Client Device Records

SAN client device state

Media Server name

Media Server state

Media Server HBA port number on which a device was discovered

Media Server HBA port mode

LUN – The LUN that is associated with the HBA Port

Non-verbose mode output (default):-

The output information is the same as for verbose mode in space-separated text format. Client records start with the letter "c" and device records start with the letter "d".

-addserver

Adds a fibre transport server to the EMM database. This operation may not be needed because FT servers are normally added automatically. It is included to allow the manual deletion of an FT server; it does not delete the server from the media servers database. To change server parameters, the `-addserver` command restarts the FT server daemon and causes FSM to reinsert the server as if it were a newly created server.

The following attributes can be set by using this command option:

`-Me media_server`

The name of the FT server to be added.

`-M master_server`

Specifies the master server that is associated with the designated media server.

`-l connection_limit`

The maximum number of connections that the FT server supports. This number is the total for the server and not per LUN or HBA. If this option is omitted, the FT server's default connection limit is used.

`-state [active | disabled]`

Identifies the assigned state of the FT server. The possible values are Active and Disabled.

-deleteserver

Deletes the specified client from the EMM database. The following attribute can be set by using this command option:

`media_server`

The name of the FT server to be deleted. There should be a confirmation step in the CLI operation to ensure that the customer is aware of the consequences of an FT server deletion. If you delete the server, the FT server daemon terminates. If the FT server is added back, it may be necessary to reboot the client to rediscover the FT server.

-changeserver

Changes attributes associated with an FT server. The following attributes can be set by using this command option:

-Me *media_server*

The name of the FT server to be changed.

-M *master_server*

Specifies the master server that is associated with the designated media server.

-l *connection_limit*

The maximum number of connections that the FT server supports. This number is the total for the server and not per LUN or HBA. If this option is omitted, the FT server's default connection limit is used.

-state [active | disabled]

Identifies the assigned state of the FT server. The possible values are Active and Disabled.

-listservers

This operation is used to display the list of FT servers and attributes associated with the servers. By default all FT servers are listed:

The following options are associated with the `listservers` command:

-Me *media_server*

Specifies the name of the media server whose attached FT servers are to be listed.

-M *master_server*

Specifies the name of the master server whose attached FT servers are to be listed.

-verbose

Specifies a detailed output for the server information.

The output can be displayed in verbose mode and non-verbose mode (by default). When all clients are listed (including all clients by master or media server), the following information appears (multi-client output):

Verbose mode output:**Server Record**

FT Server name

Version – Server NBU software version

State – FT Server state

Connection limit

If a specific SAN client is included in the `listclients` command, then the following information is displayed for that client (single client output):

Client Device Records

FT Server HBA port

FT Server HBA port mode

FT Server device state

Associated LUN

FT Connections – number of active FT Connections on the specific HBA/LUN

Non-verbose mode output (default):-

The output information is the same as for verbose mode in space-separated text format. Media Server records start with the letter "m" and device records start with the letter "d". Each HBA port number on each server gets a separate line entry in the output.

-getconfig

Retrieves the default configuration parameters for the FT server and SAN client attributes. These attributes can be set by using this command option:

-M master_server

Specifies the master server that is associated with the FT server. If this option is omitted, the local machine's master server is used.

-verbose

Specifies a detailed output for the configuration information.

-setconfig

Sets the configuration parameters for the FT server and SAN client attributes. These attributes can be set by using this command option:

-ftpref preferred | always | never

Determines if the fibre connections to the media server are preferred, must always be used, or should never be used. This value is set by default according to the global defined for the EMM server.

-ftwait minutes

Defines the number of minutes that a backup job should wait for an available fibre channel connection before it uses a standard network connection. This option is valid only when the *ftpref* type is set to preferred.

-ftrwait minutes

Defines the number of minutes that a restore job should wait for an available fibre channel connection before it uses a standard network connection. This option is only valid when the *ftpref* type is set to preferred.

`-listactive`

Lists the active FT connections. At a minimum, the following information should be obtainable from this command for each FT connection:

- SAN Client Name
- Client HBA Number
- FT Server Name
- Server HBA number
- FT Channel - Number of the FT Channel
- LUN
- Direction
- Job Number

The following options are associated with the `listactive` command:

`-C client_name`

Specifies the name of the SAN client whose active FT connections you want listed. If this attribute and the media server attribute is omitted, `-listactive` lists the information for the local machine's master server.

`-Me media_server`

Specifies the name of the FT server from whose attached clients you want the FT connections listed.

`-verbose`

Specifies a detailed output for the FT connection information.

nbhba

NAME

`nbhba`—run the utility to modify an HBA cards device ID

SYNOPSIS

```
install_path\NetBackup\bin\nbhba -modify -HBAindex string | -wwn string  
-mode target | initiator | -deviceid string  
install_path\NetBackup\bin\nbhba -l | -L
```

DESCRIPTION

`nbhba` enables an administrator to set the mode of the HBA cards in the system. The HBA cards can respond as either target mode or initiator mode devices. To change the mode of the HBA card for use with the SAN Client, change the device ID of the QLogic card. The device ID changes from its standard designation to a special designation that allows only the target mode driver to be loaded.

OPTIONS

`-list`

Lists the drivers. This operation provides a list of all HBA cards that are installed in the system and information about the cards. The following information appears for each HBA port:

- HBA index - a relative number of the HBA card in the system. This number is only valid if the system is not rebooted.
- Device ID - the device ID as read from the card.
- World Wide Name - the world wide name that is read from the card.
- Slot - the physical slot in which the card is installed in the system.
- Port - the port on the HBA card - set to 1 unless the card is multi-port.
- Fibre Attached | Fibre Not Attached - An indication if HBA is currently attached to a fibre channel.
- Mode - the mode of the card, target, or initiator.

`-modify`

Modifies the mode of the HBA card. You specify the HBA card to be changed either through the World Wide Name (wwn) or the HBA index number that is displayed in the list command.

The mode of the card can be target or initiator. Target mode is used as the terminus for a SAN Client. Initiator mode connects the media server disk resources. Optionally, the administrator can input the specific QLogic device ID for either the target mode or initiator mode driver.

Note: The `-modify` option fails if the card is attached to the fibre channel unless you specify the `-force` option.

`-wwn string`

Specifies the World Wide Name of the HBA card. This required selection criteria is used to specify which card and port to mark.

`-mode target | initiator | manual | -deviceid string`

Sets the mode of the specified HBA card. Target mode uses the HBA as the target for a SAN Client. Do not set an existing card to initiator mode unless it had been previously set to target mode.

`-HBAindex string`

Specifies a relative number of the HBA card in the system. This number is only valid if the system is not rebooted.

EXAMPLES

Example 1

The following example sets the HBA port with worldwide name "123456789ABCDEF0" to target mode:

```
nbhba -modify -wwn 123456789ABCDEF0 -mode target
```

Example 2

The following example lists information on all HBA cards in the system:

```
nbhba -L
Card #1
  HBA Index = 12
  Device ID = qldevid1
  World Wide Name = 00:00:12
  Slot = slot12
  Port = 12
  Fibre Attached
  Mode = target
Card #2
  HBA Index = 13
  Device ID = qldevid2
  World Wide Name = 00:00:13
  Slot = slot13
  Port = 13
  Fibre Not Attached
  Mode = initiator
```

nbjm

NAME

nbjm—run NetBackup Job Manager to submit jobs and acquire resources to start jobs

SYNOPSIS

```
install_path\NetBackup\bin\nbjm [-console] [-terminate]
```

DESCRIPTION

The NetBackup Job Manager binary (**nbjm**) service starts when NetBackup is started, and it remains active. The primary function of this binary is to accept the jobs that **nbpem** submitted, acquire the resources to run them, and then start the job. This service then waits for the completion of a job and sends a signal to **nbpem** when a job completes. This service also handles all IRM communications to **bpjobd** for Activity Monitor information, external resource requests, and it writes to the progress log.

OPTIONS

-console

This option enables you to start NetBackup in console mode.

-terminate

This option accepts an option parameter, which is the number of seconds to wait for jobs to finish before it terminates. The default is 60 seconds. If you enter a value of 0, **nbjm** waits until all jobs complete before it terminates. If a limit is placed on the termination, once that limit is reached, **nbjm** terminates without waiting for the completion of jobs.

SEE ALSO

nbpem, **nbrb**

nbnos

NAME

nbnos—run NetBackup binary

SYNOPSIS

```
install_path\NetBackup\bin\nbnos [-console] [-terminate] [-Factory name]  
[-IORoutput file] [-ChannelName name] [-Channel]
```

DESCRIPTION

The `nbnos` command registers an event channel, sets a channel name, starts NetBackup in console mode, and sets a factory name.

OPTIONS

`-channel`

Enables you to register an event channel. The default setting is not to register an event channel.

`-ChannelName`

Enables you to set the channel name. The default channel name is, `VRTS_NotifyEventChannel`.

`-console`

This option enables you to start NetBackup in console mode.

`-Factory name`

This option enables you to set the factory name. The default value for this setting is, `VRTS_NotifyEventChannelFactory`.

`-terminate`

This option enables you to stop `nbnos`.

nbpem

NAME

`nbpem`—run NetBackup Policy Execution Manager to schedule and submit the jobs that are due based on a policy worklist

SYNOPSIS

```
install_path\NetBackup\bin\nbpem [-console] [-terminate]
```

DESCRIPTION

The NetBackup Policy Execution Manager, `nbpem`, is a service that starts when NetBackup is started and remains active until NetBackup stops.

The `nbpem` command determines which jobs are due based on defined policies and the previous backup images. Although the function is the same, `nbpem` develops its worklist differently than `bpsched`. The `nbpem` binary creates its worklist once when it starts. It determines when to submit each job in the worklist needs and then submits that job to `nbjm` to process at the scheduled time. `nbpem` rebuilds its work list only when a job finishes, a policy is modified, or an image expires. Previous versions of `bpsched` would, based on a time interval, rebuild the work list.

In addition, this `nbpem` does the following:

- Determines a policy's priority that is based on how overdue the job is.
- Ensures that the policies are scheduled within the windows in which they are supposed to run.
- Cancels the policies that are queued, late, or outside the parameters of the scheduled window.
- Handles any policy changes and then updates the worklist with the policies that are due to run accordingly.
- Initiates retries if a particular job stops part way through the backup.

OPTIONS

`-console`

Enables you to start NetBackup in console mode.

`-terminate`

Enables you to stop the NetBackup policy execution manager.

SEE ALSO

nbjm, nbrb, nbpemreq

nbpemreq

NAME

`nbpemreq`—run NetBackup Policy Execution Manager Requisition to schedule the jobs that are due

SYNOPSIS

```
install_path\NetBackup\bin\admincmd\nbpemreq -predict -date mm/dd/yyyy  
HH:MM:SS
```

```
install_path\Netbackup\bin\admincmd\nbpemreq -predict -dateu unixtime
```

```
install_path\Netbackup\bin\admincmd\nbpemreq -updatepolicies
```

DESCRIPTION

The `nbpemreq` command enables a user to determine which jobs are due in the near future. It also reads in all entered policy updates that are in a pending state.

OPTIONS

`-predict -date mm/dd/yyyy HH:MM:SS`

Provides feedback by showing what jobs are scheduled to run in the near future. The `-date` command specifies the time more accurately.

`-predict -dateu unixtime`

Provides feedback by showing what jobs are scheduled to run in the near future. The `-dateu` command specifies the time in UNIX time (seconds).

`-updatepolicies`

Tells the NetBackup policy execution manager to read in all pending policy updates.

SEE ALSO

`nbpem`

nbpushdata

NAME

nbpushdata—push information from current database files to EMM database

SYNOPSIS

```
install_path\NetBackup\bin\nbpushdata -add  
install_path\NetBackup\bin\nbpushdata -add_5x_vmhost host  
install_path\NetBackup\bin\nbpushdata -add_5x_inactivenode host  
install_path\NetBackup\bin\nbpushdata -remove host  
install_path\NetBackup\bin\nbpushdata -modify_5x_hosts
```

DESCRIPTION

The `nbpushdata` command moves data from the current database files to the EMM database. This command is run after the upgrade installation is complete. Data is moved to the EMM database only when `nbpushdata` is run for a host that was upgraded to NetBackup 6.5. No data is moved to the EMM database from any other host except the host that is specified for `nbpushdata`.

`nbpushdata` can upgrade only a NetBackup 5.x environment with a single Global Device Database that contains unique robot numbers and unique drive names. If your environment contains the following, it cannot upgrade properly: duplicate robot numbers, duplicate drive names, or other device configuration inconsistencies.

The EMM and database daemons must be running on the EMM Server to accept data from `nbpushdata`. The NetBackup and Media Manager daemons must be started on the local host before running `nbpushdata`.

NOTE: You are only to use `nbpushdata` to upgrade an existing supported NetBackup 5.x environment that contains a single Global Device Database host. It is not a tool for merging multiple NetBackup environments.

The following list shows the required order to run `nbpushdata`. It does not indicate the order in which the hosts must be upgraded to NetBackup 6.5. The upgrade order may be different than the order to run `nbpushdata`.

For more information regarding the install and upgrade to NetBackup 6.5, refer to the *NetBackup Installation Guide* and the upgrade portal at the technical support Web site:

<http://www.symantec.com/enterprise/support/overview.jsp?pid=15143>.

Required order to run `nbpushdata`:

- 1 The server that was the Global Device Database Host in the previous version of NetBackup (`nbpushdata -add`)
- 2 Master servers (`nbpushdata -add`)
- 3 Volume Database host(s) (`nbpushdata -add` or `nbpushdata -add_5x_vmhost`)

If you intend to leave any media servers at a NetBackup 5.x version level, do the following: after you run `nbpushdata` for all Volume Database hosts, run `nbpushdata -modify_5x_hosts` on each master server.

- 4 Any remaining media servers (optional) (`nbpushdata -add`)

Hosts in groups 1, 2, and 3 must be upgraded to NetBackup 6.5 and have `nbpushdata` run on them before the NetBackup environment is functional. Hosts in group 4 are not required to be upgraded at the same time as the hosts in groups 1, 2, and 3. They may be upgraded at a later time.

Data is moved to the EMM database from all of the current database files that exist on the specified host. (See the following list.) NetBackup 6.5 binaries cannot read these files (entries for `vm.conf` and `bp.conf`) and only accesses this data from the EMM database.

- `volmgr/database/globDB`
- `volmgr/database/ltidevs`
- `volmgr/database/robotic_def`
- `volmgr/database/.namespace.chksum` (NDMP)
- `volmgr/database/ruleDB`
- `volmgr/database/poolDB`
- `volmgr/database/volDB`
- `netbackup/db/media/mediaDB`
- `netbackup/db/config/storage_units`
- `netbackup/db/config/stunit_groups`
- `volmgr/vm.conf` (Some entries)
 - `DISALLOW_NONNDMP_ON_NDMP_DRIVE`
 - `DO_NOT_EJECT_STANDALONE`
 - `DRIVE_NAME_SEED`
 - `RETURN_UNASSIGNED_MEDIA_TO_SCRATCH_POOL`
 - `SCRATCH_POOL`
 - `SSO_SCAN_ABILITY`
 - `VAULT_CLEAR_MEDIA_DESC`

- netbackup/bp.conf or the Windows registry (Some entries)
 - ALLOW_MULTIPLE_RETENTIONS_PER_MEDIA
 - DISABLE_STANDALONE_DRIVE_EXTENSIONS
 - MEDIA_ID_PREFIX
 - MEDIA_REQUEST_DELAY
 - MUST_USE_LOCAL_DRIVE
- Touch files (Some)
 - netbackup/DONT_USE_SLAVE
 - netbackup/DRIVE_ERROR_THRESHOLD
 - netbackup/MEDIA_ERROR_THRESHOLD
 - netbackup/TIME_WINDOW
 - volmgr/NO_STANDALONE_UNLOAD

OPTIONS

`-add`

Read the database files on the local host and push the information to the EMM database. Use when you run on a master server or a media server.

When `NOT_DATABASE_HOST` is set in `vm.conf`, the `poolDB`, `ruleDB`, and `volDB` files are ignored.

The size of the file determines the estimated time that remains for the `globDB`, `volDB`, and `mediaDB` files. Files that contain many deleted records cause a high estimate for the remaining time.

When `nbpushdata` runs on the Global Device Database host, it attempts to do the following: contact any host in the `globDB` file that does not yet have a complete host record in the EMM database. If a host is down or inaccessible, it can take several minutes before the operation is timed out and `nbpushdata` continues with the next host. To avoid this delay, use `nbemmcmd -addhost` to create EMM host entries for down or inaccessible hosts before running `nbpushdata`.

Some robot conversions are done when `nbpushdata` is run on a host. The following changes are only done on the hosts that were upgraded to NetBackup 6.5. Robots on NetBackup 5.x hosts are not converted. LMF robots are deleted and their drives are changed to be stand-alone drives. TSD and TS8 robots are changed to TLD and TL8 robots, respectively. The robot type changes are also made to the corresponding media and storage unit records in the EMM database.

When `nbpushdata` runs on Windows, the NetBackup 5.x device names (such as, "Tape0") convert to NetBackup 6.5 SCSI coordinate device names

(such as, "{0,0,1}"). When a device does not return its serial number, `nbpushdata` cannot do the conversion and uses "{999,999,999,999}" as the device name. After `nbpushdata` completes, you can correct the device name by using two methods. The first method is to update the device name manually by using `tpconfig`. The second method is to run the Device Configuration Wizard and let it update the device name.

When `nbpushdata` completes, one of these status messages appears:

- "Successfully added <host> records to EMM." All records for this host have been successfully moved to the EMM database. You can continue.

- "Partially successful adding <host> records to EMM." Some records for this host have not been moved to the EMM database. Depending on the number and type of records that were not moved to EMM, you may need to resolve this issue before you can continue.

- "Failed to push <host> records to EMM." or another failure message. This issue must be resolved before you can continue.

After you run `nbpushdata`, restart the NetBackup and Media Manager daemons to get the updated configuration from the EMM database.

`nbpushdata` does not modify or delete the NetBackup 5.x database files. Do not remove these files.

The `vm.conf` and `bp.conf` or Windows registry entries that moved to the EMM database are obsolete in NetBackup 6.5. Use `nbenmcmd` to modify these entries. Modifying these entries in `vm.conf`, `bp.conf`, or the Windows registry has no effect.

```
-add_5x_vmhost host
```

Use this option to move `poolDB`, `ruleDB`, and `volDB` information to the EMM database for the following situations: a 5.x media server serves as a Volume Database Host and cannot be upgraded to NetBackup 6.5. Use this option when you run on a master server.

At the completion of the command, the media server no longer is a Volume Database host. The `NOT_DATABASE_HOST` entry is added to `vm.conf`.

This option cannot be used when one of the hosts is a 32-bit platform and the other host is a 64-bit platform.

```
-add_5x_inactivenode host
```

Use this option if a clustered media server remains at NetBackup 5.x.

See the description in [“Clusters”](#) on page 417.

```
-modify_5x_hosts
```

After `nbpushdata` runs on all Volume Database hosts, run this command on each master server that has media servers running NetBackup 5.x. The device configuration on the 5.x hosts is updated so that the EMM Server is always the volume database host. In the `mediaDB` on the NetBackup 5.x

hosts, the pool numbers are adjusted to match the new pool numbers in the EMM database. The `NOT_DATABASE_HOST` entry is added to `vm.conf`.

Before `nbpushdata` modifies the database files on a NetBackup 5.x host, it creates the following backup files: `robotic_def.tpacbak`, `ltidevs.tpacbak`, and `mediaDB.bak`.

To revert to NetBackup 5.x after this command runs, manually copy the backup files to original locations on each 5.x host that this command modifies.

Disk only media servers do not require any database modifications.

`-remove host`

Remove the information from the specified host from the EMM database. Use this option to clean up after an incomplete run of `nbpushdata`, such as when a host crashes or the network fails. This command only removes the information from the last host on which you ran `nbpushdata`. You cannot run this command on a host that is updated before the last host. Use this option when you run on a master server or a media server.

NOTES

General

- A log file is automatically created in `netbackup/logs/nbpushdata` when `nbpushdata` starts.
- NetBackup 6.5 does not support pool access that is based on host, user ID, and group ID; `nbpushdata` discards these values.
- On Windows, a command window must be opened to run `nbpushdata`. You cannot be run it by clicking the icon.
- In some configurations, `nbpushdata` cannot automatically run `bpdm -convert_legacy`. If it is necessary to run this command manually, `nbpushdata` displays a message to do so.

Combined media record

- As `nbpushdata` moves records to the EMM database, the corresponding `volDB` and `mediaDB` records combine into a single EMM media record. The match is based on media ID and assigned time. If a match cannot be made automatically, the `mediaDB` record is saved in a merge table for a manual match later. `nbemmcmd` has options to view this `mediaDB` merge table (`-listmedia -mergetable`) and to match the `mediaDB` and `volDB` records manually (`-forcemerge`).

- For imported media, the assigned times are not the same in the volDB and mediaDB records, so EMM cannot match them automatically. Match these records manually by using `nbemmcmd -forcemerge`.

Multiple volume database hosts

- These former `vm.conf` options are now global (options that were applied on a host basis in NetBackup 5.x) for all hosts that use the EMM Server: `RETURN_UNASSIGNED_MEDIA_TO_SCRATCH_POOL` and `VAULT_CLEAR_MEDIA_DESC`. The values from the last volDB host where `nbpushdata` was run become the global options.
- Volume groups are merged into the EMM database by name. If the same volume group exists on two different volDB hosts, the volume groups merge.
- If a volDB host has a pool name that is not a scratch pool, but *is* a scratch pool on another volDB host, the pool becomes a scratch pool. To prevent this action, rename the pool before the upgrade.
- Pools from the various Volume Database hosts (volDB hosts) merge into the EMM database by name. This includes the default pools (None, NetBackup, and DataStore) and the user-defined pools. Scratch pools are the only exception to this rule. All scratch pools merge regardless of name. The merged scratch pool name that is used is the first scratch pool name encountered during the upgrade. Pool numbers adjust during the upgrade to be unique within the EMM database.
- Some customers may use the same pool name on two different volDB hosts. The volumes do not remain logically separated after the merge. Customers with multiple volDB hosts who are required to keep volumes with the same pool names separate, *must* rename the pools before the upgrade.
- In NetBackup 6.5, a single set of barcode rules is stored in the EMM database. The barcode rules from the various volDB hosts are added to the EMM database in the order that they are found. Only the first barcode rule with a particular barcode tag is added to the EMM database. Additional barcode rules with the same tag are not added. Manual adjustment of the barcode rules may be necessary after running `nbpushdata`.
- As media records are moved to the EMM database while `nbpushdata` runs, media record conflicts are detected and the associated media records are marked. The possible conflicts are: media ID, barcode, residence, RSM GUID, and ADAMM GUID.

Clusters

- When you run `nbpushdata` for clusters, only run the `nbpushdata -add` command on the active node. The active node obtains the necessary information from the inactive nodes. You need only run this command once in a cluster.
- If you leave clustered media servers at NetBackup 5.x, for each clustered 5.x media server node, run the following command before running `nbpushdata -modify_5x_hosts`:

```
nbpushdata -add_5x_inactivenode host
```

This command does not overwrite an existing device configuration for a node in the EMM database. You receive an error when the command is run for the active node. This error is expected and is not a problem. You need not run this command for the node that was active when `nbpushdata -add` was run on the Global Device Database host. If you do run it for all nodes, you do not need to know which node was active.
- Before you run `nbpushdata`: if any storage units are associated with an application in a cluster environment, ensure that the application cluster type exists in the EMM database. These type units are also known as an application cluster type in NetBackup 6.5.
 - a Run the following command to add a host with the virtual name of the application cluster:

```
nbemcmd -addhost -machinename virtual_name  
-machinetype app_cluster
```

where *virtual_name* is the virtual name of the application.
 - b After `nbpushdata` is complete, run the following command to associate the host with each cluster node on which the application runs:

```
nbemcmd -updatehost -add_server_to_app_cluster  
-machinename node_name -machinetype media  
-clustername virtual_name -netbackupversion 6.5  
-masterserver master_name
```

where *node_name* is a node where the application can run, *virtual_name* is the cluster virtual name, and *master_name* is the NetBackup master server name.
- If you have a Tru64 cluster that is upgraded to NetBackup 6.5, the procedure to run `nbpushdata` is different than for other types of clusters. Although you need to run `nbpushdata` only once in a typical cluster, do the following for Tru64 clusters:
 - a Run `nbpushdata -add` on the active node, as on other cluster types.
 - b Failover to each of the inactive nodes and run `nbpushdata -add -nocheck`.

nbrb

NAME

nbrb - run NetBackup Resource Broker

SYNOPSIS

```
install_path\NetBackup\bin\nbrb [-console] [-terminate]
```

DESCRIPTION

The NetBackup Resource Broker binary (*nbrb*) is a service that starts when NetBackup starts and remains active. This service makes the allocations for such things as storage units, tape drives, and client reservations. This service works closely with the EMM to obtain physical and logical the resources that a job requires to run. Physical resources can be storage units, tape drives, and media IDs. Logical resources can be named resources, max jobs per client, max jobs per policy, and multiplexed groups as resources that *nbjm* uses.

OPTIONS

-console

Enables you to start NetBackup in console mode.

-terminate

Enables you to stop the *nbrb*.

SEE ALSO

nbjm, *nbpem*

nbshreddisk

NAME

nbshreddisk - run the utility that enumerates and formats the array

SYNOPSIS

```
install_path\NetBackup\bin\nbshreddisk list [-ueid enclosure_id  
[-hosts]]  
install_path\NetBackup\bin\nbshreddisk format -udid UDID##nn#nn##nn |  
-udid_file filename [-fstype native | vxfs | -vxvm]  
install_path\NetBackup\bin\nbshreddisk mask -udid UDID##nn#nn##nn |  
-udid_file filename  
install_path\NetBackup\bin\nbshreddisk unmask -udid UDID##nn#nn##nn |  
-udid_file filename  
install_path\NetBackup\bin\nbshreddisk online -udid UDID##nn#nn##nn |  
-udid_file filename  
install_path\NetBackup\bin\nbshreddisk offline -device device_path |  
-device_file filename  
install_path\NetBackup\bin\nbshreddisk help
```

DESCRIPTION

The nbshreddisk command enables users to enumerate and format the LUNs within an array to be used for SharedDisk storage.

Run the command on one of the media servers that access the array enclosure because you need the vendor's command line interface (CLI) utilities.

OPTIONS

```
list [-ueid enclosure_id [-hosts]]
```

The action that the nbshreddisk list option takes depends on the suboptions that are included on the command line.

- list: (no other options on command line) Lists all array enclosures for which NetBackup has login credentials. The login credentials are from the master server and were expected to be previously input by tpconfig.
- nbshreddisk list -ueid enclosure_id: Lists in stdout the devices (LUNs) for a given enclosure. Only device names with the prefix "nbusd_" appear in the list.

- `nbshreddisk list -ueid enclosure_id -hosts`: Lists in `stdout` all hosts that can communicate with the specified enclosure. You can scan the list to confirm that the wanted Media Server(s) appear.

```
format -udid UDID##nn#nn##nn | -udid_file filename [-fstype native |
vxfs | -vxvm]
```

Formats all specified devices to prepare them for use by SharedDisk. The format operation unmarks, partitions, formats, mounts, unmounts, then masks each device in the device(s). You can use format devices in a call to the `nbdevconfig` command to create a disk group.

The `-udid` option formats only device `UDID##nn#nn##nn`, whereas the `-udid_file` option formats all devices that are listed in `filename`. The file must contain one or more UDIDs (unique device IDs) on separate lines. A valid line must contain a UDID## character string.

Windows does not use the `-fstype` suboption. It formats the device in a simple partition.

```
mask -udid UDID##nn#nn##nn | -udid_file filename
```

Removes the access to a specified LUN. The `mask` and `unmask` options are used to assist in triage by verifying SAN connectivity, management connectivity, and importability of a LUN.

```
unmask -udid UDID##nn#nn##nn | -udid_file filename
```

Grants the local host access to the LUN. The `mask` and `unmask` options are used to assist in triage by verifying SAN connectivity, management connectivity, and importability of a LUN.

```
offline -device device_path | -device_file filename
```

Unmounts the file system for the given device path.

```
online UDID##nn#nn##nn | -udid_file filename
```

Masks the LUN to grant it local host access, then detects the file system type and attempts to mount the file system.

```
help
```

Display usage information on the `nbshreddisk` command.

EXAMPLES

The following shows the overall process and the command line examples that are needed to format a set of devices that SharedDisk can use:

- 1 Issue the `list` command without any options to display all enclosures. From the list, select an enclosure for further discovery.
- 2 Issue another `list` command that specifies the selected enclosure. A list of all UDIDs is sent to `stdout`. Redirect the output to a filename of your choice.

- 3 Edit the file that you created in step 2 to remove the lines that correspond to UDIDs that are not wanted in the disk group. The `format` command erases the disk content of the LUN, so be sure to remove any LUNs that may already be in use in NetBackup. Comment out an unwanted UDID line by adding a `"#"` character at the front of the line. It only examines the lines that contain `UDID##`.
- 4 Issue the `format` command to format all devices in the list.

Example 1

The following example lists the arrays for which NBU has login credentials.

```
$ nbshreddisk list
Enclosure list:
```

Vendor	Array Name	Enclosure ID
NETAPP	ndmpfiler1	UEID##NETAPP##LUN##0a505b7c
IBM	IBM.1750-13ADDTA	UEID##IBM##TOTALSTORAGE##IBM.1750-13ADDTA
HP	HPEVA4000	UEID##HP##HSV##5000-1FE1-5007-0020
HP	VRTS.EVA.ROS	UEID##HP##HSV##5000-1FE1-5004-5660
EMC	000182601092	UEID##EMC##SYMMETRIX##000182601092

Scan the list to determine on which enclosure you want to perform further discovery.

Example 2

After you select an enclosure for further discovery, issue a command to output the UDIDs. The following example shows the information being redirected to a file so that it can be used with the `format` option. It lists the UDIDs in a specified enclosure.

```
$ nbshreddisk list -ueid UEID##HP##HSV##5000-1FE1-5007-0020 >
mydevlist
nbusd_v2
UDID##HP##HSV##5000-1FE1-5007-0020##6005-08B4-0010-5F49-0000-5000-0
B44-0000
nbusd_v3 UDID##HP##HSV##5000-1FE1-5007-0020##6005-08B4-0010-5F49..
nbusd_v4 UDID##HP##HSV##5000-1FE1-5007-0020##6005-08B4-0010-5F49..
```

Example 3

The following example formats all devices that are listed in the `mydevlist` file that use the VxFS file system.

```
$ nbshreddisk format -udid_file mydevlist -fstype vxfs
```

nbstl

NAME

nbstl - add, delete, modify, or list NetBackup storage lifecycle policies

SYNOPSIS

```
install_path\NetBackup\bin\nbstl -add | -modify lifecycle_name [-dc class]  
  [-dp duplication_priority] [-uf used_for,...] [-residence  
  storage_unit,...] [-pool volume_pool,...] [-server_group host,...]  
  [-managed m,...] [-rl retention_level,...][-as alt_read_server,...]  
  [-v] [-M master_server]  
  
install_path\NetBackup\bin\nbstl -delete lifecycle_name [-v] [-M  
  master_server]  
  
install_path\NetBackup\bin\nbstl -L | -l lifecycle_name [-v] [-M  
  master_server]
```

DESCRIPTION

The `nbstl` command can do the following:

- `-add` adds a new storage lifecycle.
- `-delete` deletes an existing storage lifecycle.
- `-modify` modifies an existing storage lifecycle.
- `-L` or `-l` lists one or all storage lifecycles.

OPTIONS

`-dc class`

Specifies the numeric data classification that is associated with this service.

`lifecycle_name`

Identifies the name of the storage lifecycle policy to be created, modified, deleted, or displayed.

`-M master_server`

Specifies the NBU master server. The default is the local server.

`-l`

Lists the specified storage lifecycle policy, or all storage lifecycle policies if `lifecycle_name` is not specified. The output contains only information for the storage lifecycle. It does not identify the name.

- L
Lists the specified storage lifecycle, or all services if *lifecycle_name* is not specified. It identifies the output by name.
 - dp *duplication_priority*
Specifies the duplication job priority that is associated with this storage service.
- The following destination options must all specify the same number of parameters, one for each destination of the storage service. The resulting number of destinations equals the number of parameters.
- managed *m,...*
The capacity-managed flag for each destination. The default value is 0, which disables capacity management. A value of 1 enables capacity management.
 - pool *volume_pool,...*
Specifies the volume pool for each destination.
 - priority *priority,...*
The job priority for each destination.
 - residence *storage_unit,...*
The storage unit that is to be used for each destination.
 - rl *retention_level,...*
The retention level (0-24) applied to each destination.
 - servergroup *servergroup,...*
 - as *alt_read_server,...*
The alternate read server for each destination.
 - uf *used_for,...*
Specifies when each destination is used. A value of 0 is for backup and 1 is for duplication.
 - v
Selects the verbose mode for logging.

SEE ALSO

nbpsl, nbstlutil

nbstlutil

NAME

nbstlutil - run the NetBackup storage lifecycle policies utility

SYNOPSIS

```
install_path\NetBackup\bin\nbstlutil cancel | active | inactive  
[-destination name] [-lifecycle name] [-backupid value]  
  
install_path\NetBackup\bin\nbstlutil list [-l] [-U] [-backupid value]  
[-client name] [-mediaid value] [-mediaserver name] [-storageserver  
name] [-state value]  
  
install_path\NetBackup\bin\nbstlutil diskpaceinfo [-stype name]
```

DESCRIPTION

The `nbstlutil` command provides a way for users to intervene in storage lifecycle operations. The following are the five utility functions:

`cancel`

Cancels pending duplication operations on selected image copies and marks the images as complete.

`list`

Shows the contents of an image list (EMM database). The tables can be listed that hold the information about images that lifecycles process. This option is primarily a debugging tool, but support may use the information to troubleshoot problems.

`active`

Activates lifecycle operations on selected image copies.

`inactive`

Deactivates future lifecycle operations on selected image copies, but retains the image information so that processing can resume.

`diskpaceinfo`

Reports on the space used by all disk volumes or only the disk volumes used by the specified type.

OPTIONS

`-backupid value`

Selects a specific image that is specified by *value*.

- `-client name`
Restricts the listing of images for storage lifecycle operations to only those on the client that is specified by *name*.
- `-destination name`
Selects the images that are scheduled to be duplicated to the storage unit or storage unit group that is specified by *name*.
- `-l`
Produces a condensed parsable output of the listing.
- `-lifecycle name`
Selects the images that the specified lifecycle has created.
- `-mediaid value`
Restricts the listing of images for storage lifecycle operations to only those on the media ID that is specified by *value*.
- `-mediaserver name`
Restricts the listing of images for storage lifecycle operations to only those on the media that is specified by *name*.
- `-state value`
Selects a state field that is specified by *value* in the EMM database. This option is used for debugging.
- `-storageserver name`
Restricts the listing of images for storage lifecycle operations to only those on the storage server that is specified by *name*.
- `-stype name`
Specifies the disk space type to be reported on. Variable *name* can be AdvancedDisk, SharedDisk, NearStore, PureDisk, or a vendor-supplied OpenStorage name.
- `-U`
Produces user-readable output of the listing.

nbsu

NAME

nbsu—run the NetBackup Support Utility

SYNOPSIS

```
install_path\NetBackup\bin\nbsu [-c] [-d diag] [-debug] [-g group_name]  
[-h] [-H] [-i] [-l] [-L] [-mm_e ###] [-nbu_e ###] [-nozip] [-r  
host_role] [-s name] [-t] [-v] [-xml]
```

DESCRIPTION

The `nbsu` command is a Symantec utility used to gather a wide range of diagnostic information. With no command line options, `nbsu` runs all diagnostic commands that are appropriate for the following: OS platform, OS version, NetBackup host roll, and NetBackup version.

By default, `nbsu` gathers appropriate diagnostic information that is based on the operating system and NetBackup environment. A variety of command line options allows the diagnostic information that is gathered to be *tuned* as desired.

Phase I - Determine operating system environment information including:

- Operating system name and version
- hostname
- domain name
- system root directory
- Configured host services

Phase II - Determine NetBackup environment information including:

- NetBackup installation path
- NetBackup version
- NetBackup release information
- NetBackup NBAC authentication (interactive only)
- NetBackup host "role"
 - Master server
 - Media server
 - Disk Media server
 - Tape Media server
 - Volume Database host (if applicable)
 - EMM server (if applicable)
 - Global Domain Manager

Client

Remote Administration Host

Phase III - Gather diagnostic lists:

Operating system (OS) related diagnostics

Device (DEV) related diagnostics

Network (NET) related diagnostics

NetBackup (NBU) related diagnostics

Media Manager (MM) related diagnostics

Phase IV - Select the diagnostic commands or procedures to execute:

Command line options

Operating system release level

NetBackup version level

NetBackup host role

Phase V - Execute the selected diagnostic commands or procedures:

Commands - single command line diagnostic

Procedures - multi-step diagnostic. Groups of related command line diagnostics.

Phase VI - nbsu final processing, including:

Process the information file

Remove temporary files

Update the history file

If necessary, create a bundled support package

PREREQUISITES

- nbsu is designed for use with NetBackup version 3.4 and greater.
- For nbsu to create a support package (if required), the path to the following programs must be included in the %PATH% environment variable:
 - tar
 - gzipIf these programs are not available, nbsu creates a single XML formatted output file.
- For master server and media server environments, the appropriate services or daemons must be running.

PROGRAM USAGE

- With no command line options, nbsu selects all appropriate diagnostics to run and to gather information for.

- To view a list of the diagnostic commands that `nbsu` selects, run `nbsu` with the `-l` command line option.
- Use the appropriate command line options for the following items:
 - Individual diagnostic commands
 - Groups of related diagnostic commands
 - Configuration or troubleshooting related diagnostic commands
 - NetBackup or Media Manager exit status related diagnostic commands
- To omit individual diagnostic commands or groups of related diagnostic commands, use the `-s` command line option.

OPTIONS

- `-c`
Runs only NBU configuration related commands or procedures. This option is the default condition.
- `-d diag`
Runs only the diagnostic command or procedure listed. For a list of diagnostic commands or procedures, run `nbsu` with the `-l` command line option. Multiple `-d` options may appear in the list. For example:
`-d OS_general -d OS_set`
- `-debug`
Runs `nbsu` in debug mode. Debug mode places additional program information into the file.
- `-g group_name`
Runs only the diagnostic commands or procedures that are related to the group name. Diagnostic groups are "OS", "DEV", "NET", "NBU", and "MM". Multiple `-g` options may be listed. For example:
`-g OS -g DEV`
- `-h`
Displays the terse `nbsu` command line help information.
- `-H`
Displays the full `nbsu` command line help information.
- `-i`
Interactive mode. Used to log in as a NetBackup security administrator.
- `-l`
Lists the diagnostic commands to be selected to run. Use with other command line options to display the appropriate diagnostic commands or procedures.

-l

Lists all of the nbsu 1.0 diagnostics and commands. Can be used to output a detailed report of each diagnostic to STDOUT. Includes the selection criteria and commands to be executed.

-mm_e ###

Runs only the diagnostic commands or procedures that are related to the Media Manager exit status. Multiple -mm_e options may be listed. For example:

```
-mm_e 12 -mm_e 20
```

-nbu_e ###

Runs only the diagnostic commands or procedures that are related to the NetBackup exit status. Multiple -nbu_e options may be listed. For example:

```
-nbu_e 25 -nbu_e 41
```

-nozip

Specifies that the output files are not to be compressed.

-r *host_role*

Runs only the diagnostic commands or procedures that are related to the NetBackup host role. The following are the accepted host role parameter abbreviations:

ma = Master server

me = Media server

d_me = Disk media server

t_me = Tape media server

cl = Client

emm = EMM server

gdm = Global Domain Manager

rah = Remote Administration Host

Multiple -r options may be listed. For example:

```
-r ma -r cl
```

-s *name*

Skips the diagnostic command, procedure, or group listed. For a list of diagnostic commands or procedures, run nbsu with the -l command line option. Diagnostic groups are "OS", "DEV", "NET", "NBU" and "MM".

Multiple -s options listed. For example:

```
-s OS_general -s DEV
```

-t

Runs only diagnostic commands or procedures that are related to the NetBackup troubleshooting.

-v

Outputs the internal version of nbsu.

-xml

Outputs all nbsu output into a single XML formatted file.

EXAMPLES

Example 1: List the diagnostics to be selected to run on a NetBackup node:

```
# ./nbsu -l
```

Example 2: Select an individual diagnostic command to run; do not zip the resulting support bundle:

```
# ./nbsu -d NBU_version -nozip
```

Example 3: Select the network group of diagnostics to run, but skip the NET_dd diagnostic:

```
# ./nbsu -g NET -s NET_dd
```

Example 4: Select the diagnostics that are associated with the NetBackup exit status code 41:

```
# ./nbsu -nbsu_e 41
```

Example 5: List the diagnostics that would be selected to run for the network diagnostic groups and operating system diagnostic groups on a NetBackup node:

```
# ./nbsu -l -g NET -g OS
```

Example 6: Select an individual diagnostic command to run and to not zip the resulting support bundle:

```
# ./nbsu -d NBU_version -nozip
```

Example 7: Select the network and operating system groups of diagnostics to run, but skip the NET_dd diagnostic:

```
# ./nbsu -g NET -s NET_dd -g OS
```

Example 8: Select the diagnostics that are associated with the NetBackup exit status codes 21, 25, and 41:

```
# ./nbsu -nbsu_e 21 -nbsu_e 25 -nbsu_e 41
```

nbsvrgrp

NAME

nbsvrgrp—manage server groups

SYNOPSIS

```
install_path\NetBackup\bin\admincmd\nbsvrgrp -add -grpname name [-M
  master_name] -server s1:t1:s2:t2:s3:t3...sN:tN -grptype MediaSharing |
  NOM | AltServerRestore [-grpstate ACTIVE | INACTIVE] -description text

install_path\NetBackup\bin\admincmd\nbsvrgrp -update -grpname name [-M
  master_name] [-addsvr s1:t1:s2:t2:s3:t3...sN:tN] [-remsvr
  s1:t1:s2:t2:s3:t3...sN:tN] [-grptype MediaSharing | NOM |
  AltServerRestore] [-grpstate ACTIVE | INACTIVE] [-description text]

install_path\NetBackup\bin\admincmd\nbsvrgrp -delete -grpname name [-M
  master_name]

install_path\NetBackup\bin\admincmd\nbsvrgrp -list [-M master_name]
  [-grptype MediaSharing | NOM | AltServerRestore] [-grpname name]
  [-grpstate ACTIVE | INACTIVE] [-summary | -verbose | -noverbose]

install_path\NetBackup\bin\admincmd\nbsvrgrp -list_machine_membership [-M
  master_name] -m machine_name [-t machine_type] [-summary | -verbose |
  -noverbose]
```

DESCRIPTION

The `nbsvrgrp` command adds, changes, deletes, or lists server groups.

Any authorized user can run `nbsvrgrp`.

For more information about NetBackup authorization, refer to the *NetBackup Security and Encryption Guide*.

OPTIONS

`-add`

Adds a new server group.

`-addsvr s1:t1:s2:t2:s3:t3...sN:tN`

Specifies a list of server or server-type pairs to be added to a server group. Examples of server types are *master*, *media*, and *ndmp*.

`-change`

Changes an existing server group.

- `-delete`
Deletes a server group. This operation fails if it is a Media Sharing Group and media is assigned to the group.
- `-description text`
Describes the server group. Use double quote marks if the description contains any spaces.
- `-grpname name`
Specifies the human readable name that is given to a server group. This name is case-sensitive. It may only contain the characters a-z, A-Z, 0-9, plus(+), minus(-), underscore(_), and period(.
- `-grptype type`
Specifies the group type that is used to designate the purpose of a server group. The current list of group types is *MediaSharing*, *NOM*, and *AltServerRead*.
- `-grpstate ACTIVE | INACTIVE`
Sets or changes the state of a server group. Allowable states are *ACTIVE* and *INACTIVE*.
- `-list [-summary | -verbose | -noverbose]`
Lists the information about all server groups. The `-summary` option specifies a brief format for the server group information. The `-verbose` option specifies a detailed format for the server group information. The `-noverbose` option specifies a parsable format for the server group information.
- `-list_machine_membership [-summary | -verbose | -noverbose]`
Lists the server groups in which a named machine has membership. The `-summary` option specifies a brief format for the server group information. The `-verbose` option specifies a detailed format for the server group information. The `-noverbose` option specifies a parsable format for the server group information.
- `-m machine_name`
Machine name to use with the `-list_machine_membership` option.
- `-remsvr s1:t1:s2:t2:s3:t3...sN:tN`
Specifies a list of server or server-type pairs to be removed from a server group. Examples of server types are *master*, *media*, and *ndmp*.
- `-server s1:t1:s2:t2:s3:t3...sN:tN`
Specifies a list of server (s1, s2,...) and server type (t1, t2,...) pairs to be configured in the server group. Examples of server types are *master*, *media*, and *ndmp*.

`-t machine_type`

Machine type that corresponds to the machine that is named in the `-m` option. Examples include *master*, *media server*, and *ndmp*.

NOTES

nbsvrgrp provides only limited validation of the option parameters.

EXAMPLES

EXAMPLE 1: The following command adds a new media sharing server group that is called *MyServerGroup*, with media servers *larry* and *moe*, and ndmp filer *myfiler*:

```
nbsvrgrp -add -grpname MyServerGroup -server  
larry:media:moe:media:myfiler:ndmp -grptype MediaSharing -grpstate  
ACTIVE -description "my description with spaces"
```

EXAMPLE 2: The following command lists all server groups that are configured:

```
nbsvrgrp -list -summary
```

restoretrace

NAME

restoretrace—consolidate debug logs for a restore job

SYNOPSIS

```
install_path\NetBackup\bin\admincmd\restoretrace [-master_server name]  
[-job_id number] [-client_name name] [-start_time hh:mm:ss] [-end_time  
hh:mm:ss] mmddyy [mmddyy ...]
```

DESCRIPTION

The `restoretrace` utility can be used to consolidate the debug logs for the specified restore job(s). It copies to standard output the debug log lines relevant to the specified restore job(s). The messages sort by time. The utility attempts to compensate for time zone changes and clock drift between remote servers and clients. The output is formatted so it is relatively easy to sort or group by time stamp, program name, or server or function for the following: `bprd` on the master server, `bpbrm` and `bptm/bpdm` on the media server, and `tar` on the client. For best results, set the verbose logging level to 5. Enable debug logging for `bpdbm` on the master server and for `bpcd` on all servers and clients in addition to already identified processes.

You must have administrator privileges to run this command.

OPTIONS

`-master_server name`

Name of the master server. Default is the local host name.

`-job_id number`

Job ID number of the restore job to analyze.

`-client_name name`

Client name of the jobs to analyze.

`-start_time hh:mm:ss`

Earliest time stamp to start analyzing the logs.

`-end_time hh:mm:ss`

Latest time stamp to finish analyzing the logs.

`mmddyy [mmddyy]`

One or more day stamps. This option identifies the log file names (log.mmddyy for UNIX, mmddyy.log for Windows) that are analyzed.

NOTES

Media Manager logs are not analyzed.

Windows 95/98 and Mac OS 8/9 client logs may not be analyzed.

EXAMPLES

```
C:\Program Files\VERITAS\NetBackup\bin\admincmd\restoretrace  
client peony install_path C:\Program Files\VERITAS 071502  
log.peony
```

When you initiate the utility, it consolidates debug logs for all the restore jobs for the client *peony* on *071502*. Use the *start_time/end_time* arguments to limit the window for the jobs are to be evaluated.

set_ndmp_attr

NAME

set_ndmp_attr - authorize access and set configuration values for NDMP attached robots

SYNOPSIS

```
install_path\Volmgr\bin\set_ndmp_attr
```

The set_ndmp_attr command can take any of the following sets of parameters as a single line. Two or more sets can be combined into one line (see Example 4).

```
set_ndmp_attr [-insert | -update | -delete | -display] -auth  
  [ndmp-server-host] [user-name] [password]  
set_ndmp_attr [-insert | -update | -delete | -display] -robot  
  [ndmp-server-host] [robot-device] [scsi-controller scsi-id scsi-lun]  
set_ndmp_attr -verify [ndmp-server-host]  
set_ndmp_attr -probe [ndmp-server-host] (not available for NDMP V2)  
set_ndmp_attr [-list | -l]  
set_ndmp_attr [-list_compact | -lc]
```

DESCRIPTION

set_ndmp_attr authorizes access and sets configuration values for the robots that are attached to an NDMP host and places them into the NDMP configuration database.

OPTIONS

- insert (optional)
Allows the user to insert a new authorize access entry or a new robot (must be used with -auth or -robot).
- update (optional)
Updates an NDMP entry (must be used with -auth or -robot).
- delete (optional)
Deletes an NDMP entry (must be used with -auth or -robot).
- display (optional)
Displays an NDMP entry (must be used with -auth or -robot).

- auth
Creates an entry to allow access to an NDMP client.
- robot
Sets the configuration values for an NDMP-attached robot.
- verify
Verifies that the NetBackup for NDMP server has access to the NDMP host. If a robot is configured on the NDMP host, this option verifies access to the robot.
- probe
Lists all the devices that are attached to the NDMP host.
- list or -l (optional)
Lists the current entries in the NDMP configuration database.
- list_compact or -lc (optional)
Lists a short version of the NDMP configuration database.

Note: If `-insert`, `-update`, `-delete`, or `-display` precedes the `-robot` or `-auth` options, the default is to insert or update. The default inserts or updates, depending on whether the host or robot already exists.

EXAMPLES

Example 1: Setting the authorization of an NDMP client

```
set_ndmp_attr -insert -auth stripes root
Passwd:XXXXX
Passwd:XXXXX
```

Example 2: Setting the configuration values for a robot that is attached to an NDMP client. The robot is on control 2, SCSI-ID 3, and LUN 0.

```
set_ndmp_attr -insert -robot stripes c2t310 2 3 0
```

Example 3: Run a verify

```
set_ndmp_attr -verify
Verify Host name: stripe
```

Result of Example 3:

```
Verify Host name: stripes
Connecting to host "stripes" as user "root"...
Waiting for connect notification message...
Opening session with NDMP protocol version 2...
Host info is:
  host name "stripes"
  os type "SunOS"
```

```
    os version "5.8"  
    host id "80dd14ba"  
    host supports TEXT authentication  
    host supports MD5 authentication  
Getting MD5 challenge from host...  
Logging in using MD5 method...  
Login was successful  
Opening SCSI device "c2t3l0"...  
Setting SCSI target controller 2 id 3 lun 0...  
Inquiry result is "HP      C5173-7000      3.04"
```

Example of failed verification due to incorrect password:

```
Connecting to host "stripes" as user "root"...  
Waiting for connect notification message...  
Opening session with NDMP protocol version 2...  
Host info is:  
    host name "stripes"  
    os type "SunOS"  
    os version "5.8"  
    host id "80dd14ba"  
    host supports TEXT authentication  
Logging in using TEXT method...  
ndmp_connect_client_auth failed  
set_ndmp_attr: host "stripes" failed  
set_ndmp_attr: unable to continue
```

Example 4: This example shows several sets of parameters combined

```
set_ndmp_attr -auth stripes root -robot stripes c2t3l0 2 3 0 -verify stripes
```

SPSRecoveryAsst

NAME

SPSRecoveryAsst - restore a Sharepoint portal, farm, set of databases, or documents

SYNOPSIS

```
SPSRecoveryAsst -o http://portalname [-start_date | -s start_date]  
  [--end_date | -e enddate] [-progresslog | -l progress_log]  
  [-renamefile | -r renamefiles] [-policy | -P policy] [-restore_retries  
  | -R restore_retries] [-master | -M master_server] [-redirection_host  
  | -rh redirection_host] [-redirection_virtual_server | -rv  
  http://website] [-object_file | -f path] [-disaster_recovery | -dr]  
  [-nomount | -nmt] [-verbose | -v] [-clientname | -c client_name]
```

DESCRIPTION

SPSRecoveryAsst restores an entire portal, farm, set of databases, or documents. The assistant determines the sequence in which SharePoint resources are restored. SPSRecoveryAsst should be used to perform disaster recovery of a SharePoint farm to restore the configuration database. The portals and team sites can be restored from the NetBackup Windows GUI.

OPTIONS

`-clientname | -c client_name`

Specifies a client name to use for finding backups or archives from which to restore files. This name must be as it appears in the NetBackup catalog. For SharePoint it is the front-end server name.

`-disaster_recovery | -dr`

Specify this option if you are performing a disaster recovery for SharePoint Portal Server 2003 and restoring the configuration DB object of the SharePoint farm.

`-master | -M master_server`

Specifies the name of the NetBackup server. The default is the server designated as current on the Servers tab of the Specify NetBackup Machines dialog. To display this dialog box, start the Backup, Archive, and Restore user interface on the client. Then click Specify NetBackup Machines on the File menu.

- `-nomount | -nmt`
Specifies that the database should be restored to a loading state. By default, mount is true.
- `-o http://virtualserver`
Specifies the portal or teamsite to be restored.
- `-object_file | -f path`
Specifies a file (listfile) that contains a list of files (SPSV2 objects) to be restored and can be used instead of the filenames option. List each file path in listfile on a separate line.
- `-policy | -P policy`
Specifies the policy for which the backups were performed.
- `-progresslog | -l progress_log`
Specifies the name of an existing file in which to write progress information.
For example: `c:\proglog`
The default is not to use a progress log.
- `-redirection_host | -rh redirection_hostname`
Specifies the web server on which the redirected portal or teamsite resides in a SharePoint farm. The redirected web server should be specified as `redirection_hostname`.
- `-redirection_virtual_server | -rv http://website`
Specifies a portal name or the team site name to where the selected portal or team site is to be redirected in a SharePoint farm. A user should specify the redirected portal or team site as `http://portalname | http://teamsitename`, and should already exist in a farm.
- `-R rename_file`
Specifies the name of a file with name changes for alternate-path restores.
For example: `bprestore -R /C/renamefile /C/origfile`
Where `/C/rename_file` is the file with the name change and `/C/origfile` is the file to be renamed.
Use the following form for entries in the rename file:
`change backup_filepath to restore_filepath`
The file paths must start with / (slash)
The first `backup_filepath` that is matched is replaced with the `restore_filepath` string. Use all upper case for the drive letter.
The default is to restore by using the original path.
For example, the following entry renames `C:\users\fred` to `C:\users\fred2`:

```
change /C/users/fred to /C/users/fred2
```

(Be sure to end the entry with a return.)

When you restore to a Windows client, you can also use the following method for specifying entries in the rename file:

(Do not use this method for other clients.)

```
rename bulength backup_filepath reslength restore_filepath
```

Where:

bulength is the number of ASCII characters in the backup path.

reslength is the number of ASCII characters in the restore path.

The first *backup_filepath* that is matched is replaced with the *restore_filepath* string.

For example, the following entry renames C:\fred.txt to

C:\fred2.txt:

```
rename 11 /C/fred.txt 12 /C/fred2.txt
```

(Be sure to end the entry with a return.)

```
-restore_retries | -R restore_retries
```

Specifies the number of restore retries for job submission if the job fails.

```
[-start_date | -s start_date ] [--end_date | -e enddate ]
```

Specifies the start and the end date range for the listing. The command restores only files from backups that occurred within the specified start and end date range.

-start_date specifies a start date and time for the restore window. The command restores files only from the backups that occurred at or after the specified date and time. The valid range of dates is from 01/01/1970 00:00:00 to 01/19/2038 03:14:07. The default start date is 01/01/1970 00:00:00.

The default is to return the most recent image. For backups, this image is the most recent full backup if a full backup exists. If a full backup does not exist, then the most recent incremental or user-directed backup is restored.

-end_date specifies an end date and time for the restore window. The command restores only files in the backups that occurred at or before the specified date and time. Use the same format for the start date and time. The command restores the file that has the specified backup date and time. Or it restores the file that precedes the end date and time, which is the most recent backup. The default is the current date and time.

start_date and end_date should be Unix time format.

```
-verbose | -v
```

Selects verbose mode for logging.

EXAMPLES

Example 1:

```
SPSRecoveryAsst -s 1168296907 -e 1168296907 -M combat -dr -v 99 -c  
doc "Microsoft SharePoint Resources:\Configuration DB  
(SNOWWHITE/Sps_Config_DB) "
```

Example 2:

```
SPSRecoveryAsst -f c:\test\restorelist t.txt -M combat --console -v  
99 -s 1168296907 -e 1168296907
```

tl4d

NAME

tl4d—Tape Library 4MM (TL4) process

SYNOPSIS

install_path\Volmgr\bin\tl4d

DESCRIPTION

tl4d interfaces with Media Manager to mount and unmount tapes in a Tape Library 4MM (TL4) robot. The NetBackup Device Manager service (ltid) initiates it if the Media Manager device configuration shows drives in the robot. Stopping ltid stops tl4d.

tl4d communicates with the robotics through a SCSI interface. When the connection is established (the path for robotics can be opened), tl4d puts the TL4 robot in the UP state. It then can mount and unmount tapes. If the robotics are inaccessible, tl4d changes the robot to the DOWN state. In this state, tl4d is still running and returns the robot to the UP state if it is able to make a connection.

Before you access any tapes through the NetBackup Device Manager service and tl4, you must define the following information: the media ID and slot number information for 4-mm tapes in a robot in the Enterprise Media Manager Database .

If a cleaning volume is used, it must be defined in the volume configuration. See tpclean for information on setting the frequency to clean the drive automatically.

The Internet service port number for tl4d must be in %SystemRoot%\system32\drivers\etc\services. To override the services file, create the file *install_path*\Volmgr\database\ports\tl4d with a single line that contains the service port number for tl4d. The default service port number is 13713.

You must have administrator privileges to execute this command.

ERRORS

Media Manager logs any Tape Library 4MM and robotic errors to the Windows application event log. Log entries are also made when the state changes between UP and DOWN.

tl8d

NAME

tl8d, tl8cd—Tape Library 8MM (TL8) process and control process

SYNOPSIS

```
install_path\Volmgr\bin\tl8d
```

```
install_path\Volmgr\bin\tl8cd
```

DESCRIPTION

tl8d and tl8cd interface with Media Manager to mount and unmount volumes in a Tape Library 8MM robot.

tl8d directly interfaces with the NetBackup Device Manager service (ltid). A tl8d process runs on each host with a drive connection and sends mount and unmount requests to the control process (tl8cd). tl8cd communicates with the robotics through a SCSI interface.

The following paragraph applies only to NetBackup Enterprise Server:

Tape Library 8MM robotic control software permits drives in the same robot to be configured on different hosts. tl8cd may be running on a different host than tl8d, depending on where the SCSI connection resides (see EXAMPLES). When the connection is established (the path for robotics can be opened), tl8d puts the TL8 robot in the UP state. It then can mount and unmount volumes. If the robotics are inaccessible, tl8d changes the robot to the DOWN state. In this state, tl8d is still running and returns the robot to the UP state if tl8cd is able to make a connection.

The following paragraph applies only to NetBackup Enterprise Server:

If drives are on different NetBackup hosts, enter the robotic information in the Media Manager configuration on all machines. The robot number must be the same on all machines.

tl8d and tl8cd are started when the NetBackup Device Manager service is started. They are stopped when this service is stopped.

The control process, tl8cd, is on the host that has the robotic control. tl8d starts it automatically on that host (see EXAMPLES). tl8cd stops when you stop the NetBackup Device Manager service.

Before you access any volumes through the NetBackup Device Manager service, tl8d, and tl8cd, you must define the following information: the media ID and slot number for volumes in a robot in the EMM database.

If a cleaning volume is used, it must be defined in the volume configuration. See `tpclean` for information on setting the frequency to clean the drive automatically.

If the `vm.conf` configuration option `PREVENT_MEDIA_REMOVAL` is enabled when `t18cd` is active, `t18cd` disables access to the volumes and the media access port. It disables access by issuing a command to the TL8 robot. If it is necessary to open the door of the cabinet, you must terminate `t18cd` first. By default, access to the library is allowed.

The drives are logically numbered 1 through *n*, where *n* is the number of drives in the robotic library. Use one or more of the following to determine the correct robot drive numbers:

- The Device Configuration wizard (if the robotic library and drives support serialization).
- The robotic library vendor's documentation on how to index the drive.
- The robotic test utility, or experiment by mounting media and then watch the operator display.

The Internet service port number for `t18cd` must be in `%SystemRoot%\system32\drivers\etc\services`. To override the services file, create the file `install_path\Volmgr\database\ports\t18cd` with a single line that contains the service port number for `t18cd`. The default service port number is 13705.

You must have administrator privileges to run this command.

ERRORS

Media Manager logs any Tape Library 8MM and robotic errors to the Windows application event log. Log entries are also made when the state changes between UP and DOWN.

EXAMPLES

In the following diagram, the drives and the robotics are connected to a single host. `ltid` initiates `t18d`, which in turn initiates `t18cd`.

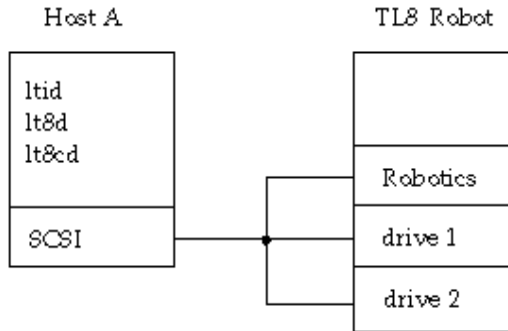

The following example applies only to NetBackup Enterprise Server:

In the following diagram, each host is connected to one drive in the robot and the robotics are connected to host A. `ltid` on each host initiates `t18d`. The `t18d` on host A also initiates `t18cd`, since that is where the robotic control is defined. Requests to mount tapes from host B go to `t18d` on host B, which sends the robotic command to `t18cd` on host A.

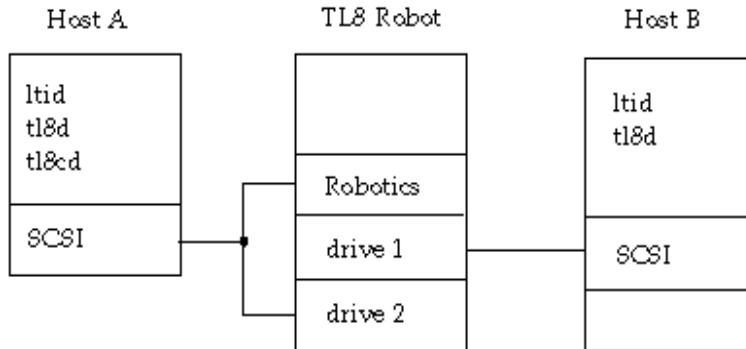

tldd

NAME

tldd, tldcd—Tape Library DLT (TLD) process and control process

SYNOPSIS

```
install_path\Volmgr\bin\tldd
```

```
install_path\Volmgr\bin\tldcd
```

DESCRIPTION

tldd and tldcd interface with Media Manager to mount and unmount volumes in a Tape Library DLT (TLD) robot.

tldd directly interfaces with the NetBackup Device Manager service (ltid). tldd runs on each host with a drive connection and sends mount and unmount requests to the control process (tldcd). tldcd communicates directly with the robotics through a SCSI interface.

The following paragraph applies only to NetBackup Enterprise Server:

TLD robotic control software permits drives in the same robot to be configured on different hosts. tldcd may be running on a different host than tldd, depending on where the interface connection resides (see EXAMPLES). When the connection is established (the path for robotics can be opened), tldd puts the TLD robot in the UP state. It then can mount and unmount volumes. If the robotics are inaccessible, tldd changes the robot to the DOWN state. In this state, tldd is still running and returns the robot to the UP state if tldcd is able to make a connection.

The following paragraph applies only to NetBackup Enterprise Server:

If drives are on different NetBackup hosts, enter the robotic information in the Media Manager device configuration on all machines. The robot number must be the same on all machines.

tldd and tldcd are started when ltid is started and stopped when this service is stopped.

tldcd is on the host that has the robotic control. tldd on that host starts it automatically. tldcd is stopped when you stop the NetBackup Device Manager service.

Before you can access any volumes through the NetBackup Device Manager service, tldd, and tldcd, you must define the following information: the media ID and slot number for volumes in the robot in the EMM database.

If a cleaning volume is used, it must be defined in the volume configuration. See `tpclean` for information on setting the frequency to clean the drive automatically.

The drives are logically numbered 1 through n , where n is the number of drives in the robotic library. Use one or more of the following to determine the correct robot drive numbers:

- The Device Configuration wizard (if the robotic library and drives support serialization).
- The robotic library vendor's documentation on how to index drives.
- The robotic test utility, or experiment by mounting media and watch the operator display.

The Internet service port number for `tldcd` must be in `%SystemRoot%\system32\drivers\etc\services`. To override the services file, create the file `install_path\Volmgr\database\ports\tldcd` with a single line that contains the service port number for `tldcd`. The default service port number is 13711.

You must have administrator privileges to run this command.

ERRORS

Media Manager logs any Tape Library DLT and robotic errors to the Windows application event log. Log entries are also made when the state changes between UP and DOWN.

EXAMPLES

In the following diagram, the two drives and the robotics connect to Host A. `ltid` initiates `tldd`, which in turn initiates `tldcd`.

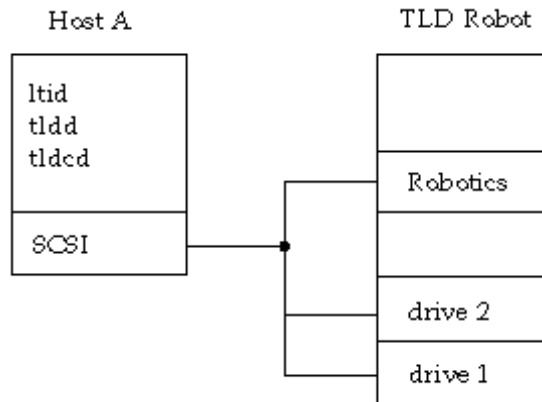

The following example applies only to NetBackup Enterprise Server:

In the following diagram, each host connects to one drive and the robotics connect to host A. `ltid` on each machine initiates `tldd`. The `tldd` on host A also initiates `tldcd`, since that is where the robotic control is defined. Requests to mount tapes from host B go to `tldd` on host B, which sends the robotic command to `tldcd` on host A.

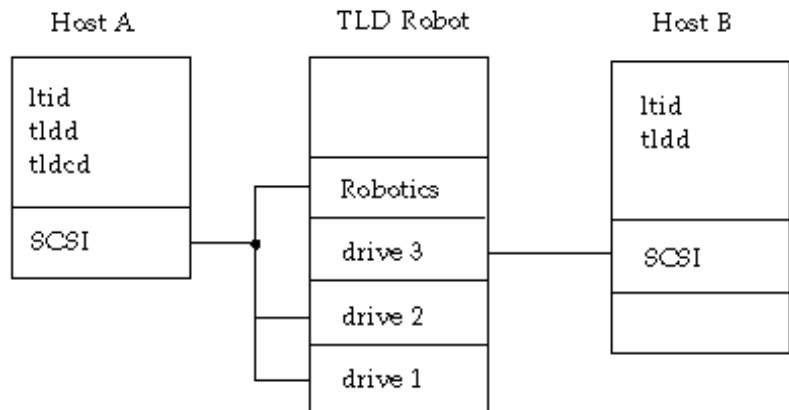

tlhd

NAME

tlhd, tlhcd—Tape Library Half-inch (TLH) process and control process

SYNOPSIS

```
install_path\Volmgr\bin\tlhd
```

DESCRIPTION

tlhd and tlhcd interface with Media Manager to mount and unmount tape volumes in a Tape Library Half-inch (TLH) robot.

tlhd directly interfaces with the NetBackup Device Manager service (ltid). tlhd runs on each host with a drive connection and sends mount and unmount requests to the control process, tlhcd.

tlhcd communicates with the IBM Automated Tape Library (ATL) library manager, which processes all requests and all control functions for the robotic library. TLH robotic control software permits drives in the same robot to be configured on different hosts. tlhcd can be running on a different host than tlhd, depending on where the IBM library control is configured (see EXAMPLES). When communication with the library is established, tlhd puts the TLH robot in the UP state and can request volume mounts and unmounts. If the library or the control process is inaccessible, tlhd changes the robot to the DOWN state. In this state, tlhd is still running and returns the robot to the UP state if tlhcd is able to make a connection.

tlhd and tlhcd are automatically started when the NetBackup Device Manager service is started and stopped when this service is stopped.

tlhcd is on the host that has the robotic control. tlhd on that host automatically starts it. tlhcd is terminated when you stop the NetBackup Device Manager service ltid.

Before you can access any volumes by using the NetBackup Device Manager service ltid, tlhd, and tlhcd, you must define the following information: the Media Manager media ID for volumes to be used in the library in the EMM database. Both the initial EMM database population and future updates can be accomplished by using Media Manager robotic inventory options.

The drives are configured by using IBM device names. Use the robotic test utility, tlhtest (or robtest if the robot is configured), to determine the device names that are associated with the robot. You can also use this utility along with

IBM's `mtlib` command-line interface to verify library communications, status, and functionality.

Configure the drive cleaning operation for the Tape Library Half-inch robotic control through an IBM library manager console. The drive cleaning operations are not available to applications that use the IBM library manager. For this reason, you cannot define the volumes to clean through Media Manager. In addition, you cannot use the Media Manager utilities or the `tpclean` command for cleaning operations on drives under TLH robotic control.

You must have administrator privileges to execute this command.

NOTES

This command applies only to NetBackup Enterprise Server.

If drives are on different hosts, enter the robotic information in the Media Manager device configuration on all machines. The robot number must be the same on all machines.

ERRORS

Media Manager logs any Tape Library Half-inch and robotic errors to the Windows application event log. Log entries are also made when the state changes between UP and DOWN.

EXAMPLES

In the following examples the device hosts can be any supported Windows server or the following UNIX servers: AIX, HP-UX, IRIX, DYNIX/ptx, or Solaris.

In the following diagram, the drives are attached to and the robotics are controlled from a single host. `ltid` initiates `tlhd`, which in turn initiates

tlhcd. The IBM Automated Tape Library service (lmcpd) must be running on Host A.

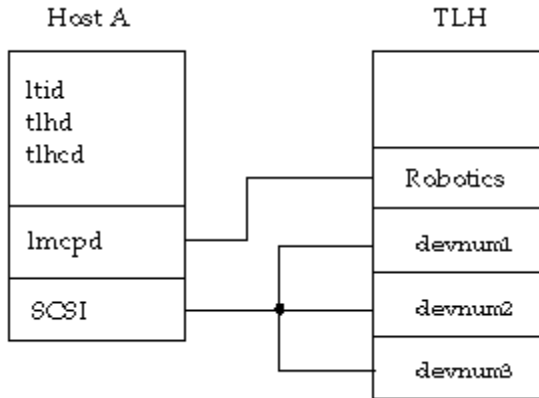

In the following diagram, each host is connected to at least one drive and the robotics are controlled from Host A. ltid on each machine initiates tlhd. The tlhd on Host A also initiates tlhcd, since that is where the robotic control is defined. Requests to mount tapes from Host B go to tlhd on Host B, which sends the robotic command to tlhcd on Host A.

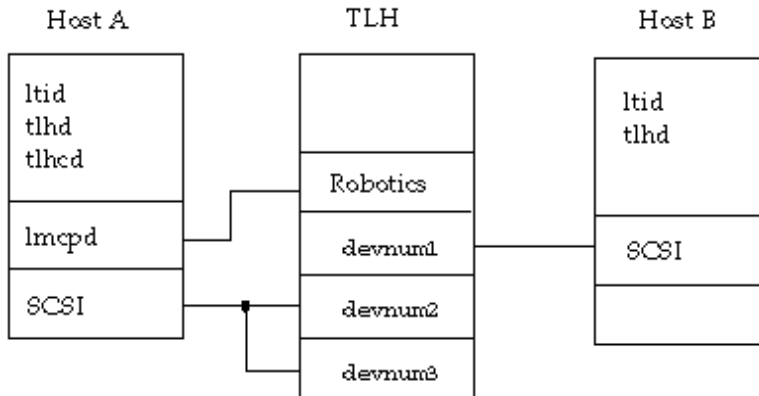

t1md

NAME

t1md—Tape Library Multimedia (TLM) process

SYNOPSIS

install_path\Volmgr\bin\t1md

DESCRIPTION

t1md interfaces with Media Manager to mount and unmount the tapes that are under control of a TLM robot automatically. The NetBackup Device Manager service (ltid) initiates it if the Media Manager device configuration shows drives in a TLM robot. Stopping ltid stops t1md.

t1md performs its tasks by sending requests to the DAS server that controls the robot.

When the connection is established, t1md puts the TLM robot in the UP mode and can mount and unmount tapes. If the connection cannot be established or robotic errors exist, t1md changes the robot to the DOWN mode. In this state, t1md is still running and returns the robot to the UP mode when the problem no longer exists.

The Internet service port number for t1md must be in %SystemRoot%\system32\drivers\etc\services. To override the services file, create the file *install_path*\Volmgr\database\ports\t1md with a single line that contains the service port number for t1md. The default service port number is 13716.

The drives are configured by using DAS/SDLL device names. You can use the robotic test utility, t1mtest (robtest if the robot is configured), to determine the device names that are associated with the robot.

You must have administrator privileges to execute this command.

NOTES

This command applies only to NetBackup Enterprise Server.

ERRORS

Media Manager logs TLM and network errors to the Windows application event log. Log entries are also made when the mode changes between UP and DOWN.

tpautoconf

NAME

tpautoconf—manage the EMM Server

SYNOPSIS

```
install_path\Volmgr\bin\tpautoconf -get_gdbhost
install_path\Volmgr\bin\tpautoconf -set_gdbhost host_name
install_path\Volmgr\bin\tpautoconf -verify ndmp_host_name
install_path\Volmgr\bin\tpautoconf -probe ndmp_host_name
install_path\Volmgr\bin\tpautoconf -report_disc
install_path\Volmgr\bin\tpautoconf -replace_drive drive_name -path
drive_path
install_path\Volmgr\bin\tpautoconf -replace_robot robot_number -path
robot_path
```

DESCRIPTION

The Device Configuration wizard normally uses `tpautoconf` to discover devices. This wizard calls `tpautoconf` with a different set of options.

The `get` and the `set` options that are described here are useful only in special situations. For example, use them to specify a different host as the Enterprise Media Manager Server. The Enterprise Media Manager Server name is automatically defined when NetBackup is installed.

See the Configuring Storage Devices chapter of the *NetBackup Administrator's Guide* for information about how to manage the Enterprise Media Manager Server.

To reconfigure the devices on the EMM database to reflect a serial number change that a configured device replacement caused, use the following options: `-report_disc`, `-replace_drive`, `-replace_robot`. The correction process requires that after hardware replacement, at least one system must be available through the operating system. You may need to re-map, re-discover, and reboot the system.

Refer to "Making Changes to your Existing Configuration" in the *NetBackup Shared Storage Guide* for instruction on how to reconfigure the EMM database.

After you configure the server(s), use the `-report_disc` option to scan the current hardware, and compare it with the configured hardware. A list of

discrepancies is produced and shows the replaced hardware, and the new hardware.

Note: Note: Not all servers have access to robotic hardware. Even though no access is expected, these robots are listed as missing.

All servers must be running NetBackup 5.0 or better for `-replace_drive` or `-replace_robot` to properly reconfigure them. For the servers that run older versions of NetBackup, manual reconfiguration is required after running `-replace_drive` and `-replace_robot`.

The final step to add replacement hardware is to configure the hardware on all servers by their operating systems. Then run the Device Configuration wizard to configure the new path information.

You must have administrator privileges to run this command.

OPTIONS

`-get_gdbhost`

Returns the name of the EMM server host.

`-set_gdbhost host_name`

Sets the name of the EMMSERVER entry in `bp.conf`.

`-probe ndmp_host_name`

Lists all the devices that are attached to the NDMP host..

`-report_disc`

Enables the device data to be queried from the EMM server to enable a "diff" to be run on these data records against those scanned. You can run this command on reconfigured servers to produce a list of new and missing hardware. This command scans for new hardware and produces a report that shows the new and the replaced hardware.

`-replace_drive drive_name -path drive_path`

The EMM database is used to query or update robot drives. In addition, `tpautoconf` updates the systems that run pre-NetBackup 5.1 versions.

NOTE: The `drive_path` variable is a non-NDMP Windows device path for drives. Use the path in the `{p,b,t,l}` format (`p` - port, `b` - bus, `t` - target, and `l` - lun. This information is located in the registry.

`-replace_robot robot_number -path robot_path`

The EMM database is used to query or update robot records. In addition, `tpautoconf` updates the systems that run pre-NetBackup 5.1 versions.

NOTE: The *robot_path* variable is a non-NDMP Windows device path for robots. Use it in the *{p,b,t,l}* format: *p* is the port, *b* is the bus, *t* is the target, and *l* is the lun. This information is located in the registry.

```
-verify ndmp_host_name
```

Verifies the server name of the NDMP host.

EXAMPLES

Example 1

The following command returns the name of the host where the Enterprise Media Manager Database is stored:

```
tpautoconf -get_gdbhost
```

Example 2

The following command sets the Enterprise Media Manager Server to be the host server2:

```
tpautoconf -set_gdbhost server2
```

Example 3

The following example shows how the `-report_disc` command is used to report discrepancies between detected devices and the EMM Database. In addition, an example of how to use the `-replace_drive drive_name -path drive_path` command is included.

```
# install_path\Volmgr\bin\tpautoconf -report_disc
===== New Device (Tape)
=====
Inquiry = "QUANTUM DLT8000          0250"
Serial Number = PXB08P3242
Drive Path = /dev/rmt/119cbn
Found as TLD(6), Drive = 1
===== Missing Device (Drive)
=====
Drive Name = QUANTUMDLT800014
Drive Path = /dev/rmt/9cbn
Inquiry = "QUANTUM DLT8000          0250"
Serial Number = PXB08P1345
TLD(6) definition Drive = 1
Hosts configured for this device:
Host = dandelion
```



```
Host = avocadocat
```

```
# install_path\Volmgr\bin\tpautoconf -replace_drive  
QUANTUMDLT800014 -path /dev/rmt/119cbn
```

```
Found a matching device in EMM DB, QUANTUMDLT800014 on host  
dandelion
```

```
  update on host dandelion completed
```

```
Found a matching device in EMM DB, QUANTUMDLT800014 on host  
avocadocat
```

```
  update on host avocadocat completed
```

tpclean

NAME

`tpclean`—manage the cleaning of the tape drive

SYNOPSIS

```
install_path\Volmgr\bin\tpclean -L  
install_path\Volmgr\bin\tpclean -C drive_name  
install_path\Volmgr\bin\tpclean -M drive_name  
install_path\Volmgr\bin\tpclean -F drive_name cleaning_frequency
```

DESCRIPTION

`tpclean` enables you to monitor Media Manager tape drive usage and optionally configure tape drives to be cleaned automatically. (Exception: drives in ACS,ODL, or TLH robots; or QIC drives).

Media Manager tracks the total amount of time that volumes have been mounted in the drives. You can use `tpclean` to specify a cleaning frequency (in hours) for a drive.

The cleaning of the drive occurs if the following are true:

- The mount time exceeds the cleaning frequency.
- A TapeAlert "CLEAN NOW" or "CLEAN PERIODIC" flag has been raised.
- The drive is in a robot.
- The Media Manager volume configuration shows a cleaning tape in the robot.

The Comment field in the `tpclean -L` output contains the message, NEEDS CLEANING, if the following are true. You can then manually clean the drive and reset the mount time by using the `-M` option.

- The mount time exceeds the cleaning frequency.
- The drive is a stand-alone drive or does not have a defined cleaning tape.

For the `-C`, `-M`, and `-F` options, the NetBackup Device Manager service must be running.

See the appendix of the *NetBackup Administrator's Guide* for information about the TapeAlert feature and other related drive cleaning topics.

You must have administrator privileges to run this command.

OPTIONS

`-C drive_name`

Initiates the cleaning of a drive in a robot. The drive must be defined in a robot and a defined cleaning tape in the Media Manager volume configuration. The mount time is reset to zero. The drive name is the name that was assigned to the drive, when it was added.

`-L`

Prints the cleaning statistics.

`-M drive_name`

Use this option to indicate that the drive was manually cleaned. The mount time is reset to zero. The drive name is the name that was assigned to the drive when it was added to the device configuration.

`-F drive_name cleaning_frequency`

Sets the cleaning frequency for the specified drive to *cleaning_frequency* hours. The drive name is the name that was assigned to the drive when it was added. The value of *cleaning_frequency* must be between 0 hours and 10,000 hours.

The following applies only to NetBackup Enterprise Server:

A frequency-based cleaning is not supported for shared drives.

NOTES

`tpconfig -d`, `tpconfig -l`, and `vmopr cmd` may truncate long drive names. Use `tpconfig -dl` to obtain the full drive name.

`tpclean` truncates drive names to 22 characters.

EXAMPLES

The following example displays cleaning statistics. An asterisk next to the drive type indicates that the device is defined as robotic.

```
#tpclean -L
Drive Name   Type   Mount Time   Frequency   Last Cleaned   Comment
*****     ****   *****     *****     *****     *****
rob_A_drv1   8mm*   11.4         30          14:33 05/29/92
4mm_drv5     4mm    5.6          10          13:01 06/02/92
dlt_drv6     dlt    3.0          0           N/A
```

The following example sets the cleaning frequency for the drive named `dlt_drv6` to 25 hours. The drive is flagged as needing cleaning after 25 hours of mount time has occurred.

```
tpclean -F dlt_drv6 25
```

The following example resets the mount time for the drive named `rob_A_drv1` to zero. You normally use this command after you manually clean the drive.

```
tpclean -M rob_A_drv1
```

The following example initiates the cleaning of drive `rob_A_drv1`. This example assumes that the drive is a robotic drive with a cleaning tape defined. The mount time is reset to zero.

You can use the `-C` option to force the cleaning of a drive before you reach *cleaning_frequency*. Normally, robotic drives are cleaned automatically when their mount time exceeds the cleaning frequency.

```
tpclean -C rob_A_drv1
```

Note: To use a cleaning tape, the Cleanings Remaining for that tape must be greater than zero. (This value appears in the volume list of the **Media** node in the NetBackup Administration Console or from the `vmquery` command.) This cleaning count refers to how many more times the cleaning tape can be used. You can change this count by using the **Media** node or the `vmchange` command.

tpconfig

NAME

tpconfig—run tape configuration utility

SYNOPSIS

display device configuration:

```
install_path\Volmgr\bin\tpconfig -d | -l | -dl
```

add a drive:

```
install_path\Volmgr\bin\tpconfig -add -drive -type drvtype -port port -bus  
bus -target target -lun lun [-asciiiname asciidrivename] [-index  
drvindex] [-shared [yes|no]] [-cleanfreq hours] [-comment comment]  
[-drstatus [UP | DOWN | DISABLED]] [-scsi_protection [SPR | SR | NONE]]  
[-robot robnum -roctype roctype] [-noverify] [-robdrnum robdrvnum |  
-VendorDrvName vendor_drive_name] [-ACS acsnum -LSM lsmnum -PANEL  
panelnum -DRIVE drivenum] [preview]
```

```
install_path\Volmgr\bin\tpconfig -add -drive -type drvtype -path drivepath  
[-nh ndmp_hostname] [-asciiiname asciidrivename] [-index drvindex]  
[-shared [yes|no]] [-cleanfreq hours] [-comment comment] [-drstatus  
[UP | DOWN | DISABLED]] [-robot robnum -roctype roctype] [-robdrnum  
robdrvnum | -VendorDrvName vendor_drive_name | -ACS acsnum -LSM lsmnum  
-PANEL panelnum -DRIVE drivenum] [preview]
```

update a drive:

```
install_path\Volmgr\bin\tpconfig -update -drive drvindex [-type drvtype]  
[-port port -bus bus -target target -lun lun ] [-nh ndmp_hostname -path  
drivepath] [-noverify] [-newasciiiname asciidrivename]] [-shared  
[yes|no]] [-cleanfreq hours] [-comment comment] [-drstatus  
[UP|DOWN|DISABLED]] [-robot robnum -roctype roctype] [-robdrnum  
robdrvnum | -VendorDrvName vendor_drive_name] [-ACS acsnum -LSM lsmnum  
-PANEL panelnum -DRIVE drivenum]
```

delete a drive:

```
install_path\Volmgr\bin\tpconfig -delete -drive drvindex  
install_path\Volmgr\bin\tpconfig -multiple_delete -drive  
drvindex1:drvindex2: ... drvindexN
```

add disk array host credentials:

```
install_path\Volmgr\bin\tpconfig -add -disk_array array_hostname  
-disk_user_id user_ID -arraytype array_type -requiredport  
IP_port_number [-password password [-key encryption_key]]
```

update disk array host credentials:

```
install_path\Volmgr\bin\tpconfig -update -disk_array array_hostname  
-disk_user_id user_ID -requiredport IP_port_number [-arraytype  
array_type] [-password password [-key encryption_key]]
```

delete disk array host credentials:

```
install_path\Volmgr\bin\tpconfig -delete -disk_array array_hostname  
-disk_user_id user_ID [-arraytype array_type]
```

display disk arrays:

```
/usr/opensv/volmgr/bin/tpconfig -ddiskarrays
```

add a robot:

```
install_path\Volmgr\bin\tpconfig -add -robot robnum -rodtype rodtype -port  
port -bus bus -target target -lun lun
```

```
install_path\Volmgr\bin\tpconfig -add -robot robnum -rodtype rodtype [-nh  
ndmp_hostname] [-robpath changername] [-bus bus -target target -lun lun]
```

```
install_path\Volmgr\bin\tpconfig -add -robot robnum -rodtype rodtype  
-cntlhost cntlhost
```

update a robot:

```
install_path\Volmgr\bin\tpconfig -update -robot robnum [-rodtype rodtype]  
[-port port -bus bus -target target -lun lun | -cntlhost cntlhost |  
-tlh_library_name tlh_library_name]
```

```
install_path\Volmgr\bin\tpconfig -update -robot robnum [-rodtype rodtype]  
[-robpath changername] [-nh ndmp_hostname] [-bus bus] [-target target]  
[-lun lun]
```

```
install_path\Volmgr\bin\tpconfig -update -robot robnum [-rodtype rodtype]  
[-pird [yes|no]]
```

delete a robot:

```
install_path\Volmgr\bin\tpconfig -delete -robot robnum
```

```
install_path\Volmgr\bin\tpconfig -multiple_delete -robot robnum1:robnum2:  
... robnumN
```

add a drive path:

```
install_path\Volmgr\bin\tpconfig -add -drpath -path drivepath [-nh  
ndmp_hostname] -asciiname asciidrvname [-drstatus [UP|DOWN|DISABLED]]  
[-noverify]
```

```
install_path\Volmgr\bin\tpconfig -add -drpath -port port -bus bus -target
target -lun lun -asciiname asciidrvname [-drstatus [UP|DOWN|DISABLED]]
[-noverify]
```

update a drive path:

```
install_path\Volmgr\bin\tpconfig -update -drpath -old_path drivepath
-path drivepath [-nh ndmp_hostname] -asciiname asciidrvname [-drstatus
[UP|DOWN|DISABLED]] [-noverify]
```

```
install_path\Volmgr\bin\tpconfig -update -drpath -old_port port -old_bus
bus -old_target target -old_lun lun -port port -bus bus -target target
-lun lun -asciiname asciidrvname [-drstatus [UP|DOWN|DISABLED]]
[-noverify]
```

delete a drive path:

```
install_path\Volmgr\bin\tpconfig -delete -drpath -path drivepath
-asciiname asciidrvname [-nh ndmp_hostname]
```

```
install_path\Volmgr\bin\tpconfig -delete -drpath -port port -bus bus
-target target -lun lun -asciiname asciidrvname
```

display NDMP host credentials for this host:

```
install_path\Volmgr\bin\tpconfig -dnh
```

display NDMP host credentials for all hosts:

```
install_path\Volmgr\bin\tpconfig -dnh -all_hosts
```

display NDMP default credentials for all hosts:

```
install_path\Volmgr\bin\tpconfig -ddnh
```

add an NDMP host using default credentials:

```
install_path\Volmgr\bin\tpconfig -add -nh ndmp_hostname
```

add NDMP host credentials:

```
install_path\Volmgr\bin\tpconfig -add -nh ndmp_hostname
-user_id|-filer_user_id user ID [-password password [-key encryption
key]]
```

update NDMP host credentials:

```
install_path\Volmgr\bin\tpconfig -update -nh ndmp_hostname
-user_id|-filer_user_id user ID [-password password [-key encryption
key]]
```

Note: If the `-key` option is specified, `tpconfig` assumes the password to be provided in MD5 encrypted format.

delete NDMP host credentials:

```
install_path\Volmgr\bin\tpconfig -delete -nh ndmp_hostname  
-user_id| -filer_user_id user ID
```

delete multiple NDMP host credentials. This option applies only to credentials that are specific to this host and the specified filer. In other words, it has no default or no filer credentials.

```
install_path\Volmgr\bin\tpconfig -multiple_delete -nh ndmp_hostname_1 :  
ndmp_hostname_2 : ... : ndmp_hostname_N
```

add default NDMP host credentials:

```
install_path\Volmgr\bin\tpconfig -add -default_user_id user ID [-password  
password [-key encryption key]]
```

update default NDMP host credentials. If the -key option is specified, tpconfig assumes the password to be provided in MD5 encrypted format.

```
install_path\Volmgr\bin\tpconfig -update -default_user_id user ID  
[-password password [-key encryption key]]
```

delete default NDMP host credentials:

```
install_path\Volmgr\bin\tpconfig -delete -default_user_id
```

retrieve default NDMP host credentials:

```
install_path\Volmgr\bin\tpconfig -dev_ping [-drive -path  
drivepath| -robp robotpath] [-nh ndmp_hostname]
```

```
install_path\Volmgr\bin\tpconfig -dev_ping [-drive] -port port -bus bus  
-target target -lun lun
```

add virtual machine credentials:

```
tpconfig -add -virtual_machine virtual_machine_name -vm_user_id user_id  
-vm_type virtual_machine_type -requiredport IP_port_number [-password  
password [-key encryption_key]]
```

update virtual machine credentials:

```
tpconfig -update -virtual_machine virtual_machine_name -vm_user_id  
user_id -vm_type virtual_machine_type -requiredport IP_port_number  
[-password password [-key encryption_key]]
```

delete virtual machine credentials:

```
tpconfig -delete -virtual_machine virtual_machine_name -vm_user_id  
user_id [-vm_type virtual_machine_type]
```

display virtual machine credentials:

```
tpconfig -dvirtualmachines
```

Add OpenStorage credentials:

```
/usr/opensv/volmgr/bin/tpconfig -add -storage_server server_name -stype
server_type -sts_user_id user_ID [-password password] [-st
storage_type]
```

Update OpenStorage credentials:

```
/usr/opensv/volmgr/bin/tpconfig -update -storage_server server_name -stype
server_type -sts_user_id user_ID [-password password]
```

Delete OpenStorage credentials:

```
/usr/opensv/volmgr/bin/tpconfig -delete -storage_server server_name -stype
server_type -sts_user_id user_ID
```

Display OpenStorage credentials:

```
/usr/opensv/volmgr/bin/tpconfig -dsh [-stype server_type]
```

Display OpenStorage credentials for all media servers:

```
/usr/opensv/volmgr/bin/tpconfig -dsh -all_hosts
```

retrieve device information from a device:

```
install_path\Volmgr\bin\tpconfig -dev_ping [-drive -path drivepath |
-robpath robotpath] [-nh ndmp_hostname]
```

list device data in a customer's environment:

```
install_path\Volmgr\bin\tpconfig -emm_dev_list [-noverbose]
```

DESCRIPTION

The `tpconfig` command can be used to configure drives, drive arrays, robots, drive paths, and NDMP hosts for use with NetBackup. The default for `install_path` is `C:\Program Files\VERITAS`.

When your device configuration changes are complete, stop and restart the NetBackup Device Manager service.

OPTIONS

-ACS *acsnum*

-LSM *lsmnum*

-PANEL *panelnum*

-DRIVE *drivenum*

These four options are only applicable for NetBackup Enterprise Server.

These options specify the configuration for ACS (Automated Cartridge System) robots.

acsnum specifies the number for the robotic library as configured on the ACS library software host.

lsmnum specifies the Library Storage Module that has this drive.

panelnum specifies the robot panel where this drive is located.

drivenum specifies the number of this drive.

-add

Adds a drive or a robot, depending on the accompanying options.

-arraytype *array_type*

Specifies the type of the disk array. The following are the possible values:

0 - HP EVA disk array controllers

1 - EMC CLARiiON disk array controllers

2 - EMC Symmetrix disk array controllers

3 - IBM System Storage disk array controllers

4 - NetApp disk array controllers

This option can be used only if the NetBackup Snapshot Client license key has been installed.

-asciiname *asciidrivename*

Specifies a name for the drive. This name identifies the drive to Media Manager. If you do not specify a drive name, Media Manager generates a name.

The following applies only to NetBackup Enterprise Server:

If you add or update shared drives, make the drive name as descriptive as possible.

-bus *bus*

Specifies an existing SCSI bus number to which the robot or drive connects. You can find this information in the registry.

-cleanfreq *hours*

Specifies the number of hours between drive cleanings. When you add a drive, NetBackup starts to record the amount of time that volumes are mounted in that drive.

If the drive is in a robot and a cleaning volume is defined in the robot, the cleaning occurs in the following situation: when the accumulated mount time exceeds the time that you specify for cleaning frequency. NetBackup resets the mount time when the drive is cleaned.

If the drive is stand-alone or a cleaning tape is not defined, the message NEEDS CLEANING appears in the `tpclean -L` output comment field. To clean the drive, use the `tpclean` command.

-cntlhost *cntlhost*

This option is only applicable for NetBackup Enterprise Server.

For a robot whose robotic control is on another host, this option specifies the host that controls the robotic library.

This option applies only to the following robots: TL8, TLD, and TLH robots that can have the robotic control on another host, and ACS robots and TLM robots.

For an ACS robot, specify the host name where the ACS library software is installed.

For a TLM robot, specify the host name where the DAS server software is installed.

`-comment comment`

Adds a comment about the drive. This field is useful for storing SCSI inquiry data so you can easily check the drive type and firmware level.

`-d`

Lists the current configuration information.

`-ddiskarrays`

Displays all configured disk arrays.

`-default_user_id user ID`

The user can configure a user name and password for all media servers and NDMP host combinations under a given master server. A user only needs to add a user name and password once per filer. Use this option with the `-add`, `-update`, or `-delete` commands to specify the user name and password.

`-delete`

Deletes a drive or robot, depending on the accompanying options.

`-disk_array array_hostname`

Specifies the hostname of the disk array. This option can be used only if the NetBackup Snapshot Client license key has been installed.

`-disk_user_id user_ID`

Specifies the user name that NetBackup must use to communicate with a disk array. This option can be used only if the NetBackup Snapshot Client license key has been installed.

`-dl`

Lists the full drive name.

`-drive`

Use this option with the `-add` option to specify that the action is for a drive.

`-drive drvindex`

Use this option with the `-update`, `-delete`, or `-multiple_delete` options to specify the drive index and that the action is for a drive.

`-drpath`

The drive path that is added, updated, or deleted.

`-drstatus UP|DOWN|DISABLED`

Sets the initial status of the tape drive to the UP, DOWN, or DISABLED state. Discovered drive paths are enabled (UP) by default. An administrator or operator can disable or configure the drive path up/down. The user can also perform this action with options in the Device Management window.

A drive status of DISABLED means that NetBackup stores the path but does not use it. In addition, if subsequent discoveries of this drive path occur, NetBackup does not configure it for use.

`-dvirtualmachines`

Displays all configured virtual machines.

`-emm_dev_list [-noverbose]`

Lists the complete tape device configuration as seen by the EMM database. This information includes all media servers, master server, NDMP hosts and their credentials.

`-filer_user_id user ID`

Enables a user to configure a user name and password for all the media servers that are connected to a filer. A user only needs to add a user name and password once per filer. Use this option with the `-add`, `-update`, or `-delete` commands to specify the user name and password.

`-index drvindex`

A drive index is a unique number that is used to identify the drive. When you add a drive you are not required to supply a drive index. Media Manager uses the next available drive index. Each drive on a particular host must have a unique index number.

`-l`

Lists the current device configuration. Displays the Windows device paths in the {p,b,t,l} encoded form: p is the port, b is the bus, t is the target, and l is the lun.

`-lun lun`

Specifies the logical unit number (or SCSI ID) to which the robot or drive connects. You can find this information in the registry.

`-multiple_delete`

Deletes multiple drives or robots, depending on the accompanying options.

`-newasciiname asciidrivename`

Specifies a new name for the drive.

-noverify

If this option is specified, drive paths are not verified. Normally, `tpconfig` verifies that the no rewind on close drive path has the correct minor number bits that relate to the following: no rewind, variable, Berkeley-style, and so on. This option is normally not required, but may be helpful if you use non-standard platform device files. If this option is specified, make sure the device files are correct.

-old_bus *bus*

Specifies the SCSI bus number that a user may want to add, upgrade, or delete.

-old_lun *lun*

Specifies the logical unit number (or SCSI ID) to which the robot or drive connects. You can find this information in the registry. Use this command to add, upgrade, or delete an existing logical unit number.

-old_port *port*

Specifies an existing SCSI port number that a user may want to add, upgrade, or delete.

-old_target *target*

Specifies an existing target number (or SCSI ID) to which the robot or drive connects. Use this command to add, upgrade, or delete an existing target.

-path *drivepath*

Specifies the drive's device path on the NDMP filer.

NOTE: The *drive_path* variable is a non-NDMP Windows device path for drives. Use it in the $\{p,b,t,l\}$ format: *p* is the port, *b* is the bus, *t* is the target, and *l* is the lun. This information is located in the registry.

-pird *yes|no*

This option sets or clears the PIRD state of the robot (pend if the robot is down). If a robot is in a PIRD state, any storage-unit-related mount requests for this robot pend when the robotic control is down.

-port *port*

Specifies the SCSI port number to which the robot or drive connects. You can find this information in the registry.

-requiredport *IP_port_number*

Specifies the IP port number on which the disk array accepts a connection from NetBackup.

-robdrnum *robdrvnum*

Specifies the physical location (within the robot) of the drive. If you assign the wrong number, NetBackup does not detect it. An error eventually occurs because the robotic control attempts to mount media on the wrong drive.

You can usually determine the physical location by checking the connectors to the drives or the vendor documentation.

`-robot robnum`

A unique number that identifies the robot to NetBackup. You assign the robot number when you add the robot by using the `add` option.

The following applies only to NetBackup Enterprise Server:

Robot numbers must be unique for all robots that share the same EMM server (and therefore use the same EMM database). This requirement applies regardless of the robot type or the host that controls them. For example, you have two TLD robots that have different hosts control, but they have the same EMM server. In this example, the robot numbers must be different.

`-robpath robpath`

Specifies the robot's device path on the NDMP filer.

NOTE: The *robpath* variable is a non-NDMP Windows device path for robots. Use it in the `{p,b,t,l}` format: *p* is the port, *b* is the bus, *t* is the target, and *l* is the lun. You can find this information in the registry.

`-roptype roptype`

Specifies the type of robot that you configure and can be any of the types that NetBackup supports on Windows servers.

Robot type can be any of the following for NetBackup Enterprise Server:

`acs`, for Automated Cartridge System robotic libraries

`t14`, for Tape Library 4mm robotic libraries

`t18`, for Tape Library 8mm robotic libraries

`t1d`, for Tape Library DLT robotic libraries

`t1h`, for Tape Library Half-inch robotic libraries

`t1m`, for Tape Library Multimedia robotic libraries

Robot type can be any of the following for NetBackup Server:

`t14` for Tape Library 4mm

`t18` for Tape Library 8mm

`t1d` for Tape Library DLT

`-shared yes/no`

Indicates that you want to add or update shared drives.

`-st storage_type`

Specifies a numeric value that identifies the storage server properties. The storage vendor provides this value. Whether the disk is formatted and how it is attached are mutually exclusive and complementary.

- formatted disk = 1

- raw disk = 2
- direct attached = 4
- network attached = 8

The *storage_type* value is the sum of the numeric value of whether or not the disk is formatted (1 or 2) and the numeric value of how the disk is attached (4 or 8). The default value is 9 (a network attached, formatted disk).

`-storage_server server_name`

Specifies the host name of the storage server.

`-sts_user_id user_id`

Specifies the user name that is needed to log into the storage server. If the storage server does not require login credentials, enter dummy credentials.

`-stype server_type`

Specifies a string that identifies the storage server type. The storage vendor provides the string.

`-target target`

Specifies the target number (or SCSI ID) to which the robot or drive connects. You can find this information in the registry.

`-tlh_library_name tlh_library_name`

Specifies the TLH robotic library name.

`-type drvtype`

Specifies the type of drive that you configure.

Drive type can be any of the following for NetBackup Enterprise Server:

4mm for 4mm tape drives

8mm for 8mm tape drives

8mm2 for 8mm tape drives 2

8mm3 for 8mm tape drives 3

d1t for DLT tape drives

d1t2 for DLT tape drives 2

d1t3 for DLT tape drives 3

hcart for Half-inch cartridge drives

hcart2 for Half-inch cartridge drives 2

hcart3 for Half-inch cartridge drives 3

qscsi for Quarter-inch cartridge drives

Drive type can be any of the following for NetBackup Server:

4mm for 4mm tape drive

8mm for 8mm tape drives

dlt for DLT tape drives

hcart for Half-inch cartridge drives

qscsi for Quarter-inch cartridge drive.

`-VendorDrvName vendor_drive_name`

This option is only applicable for NetBackup Enterprise Server.

Specifies the IBM device name for a TLH robotic drive or the DAS drive name for a TLM robotic drive.

`-virtual_machine virtual_machine_name`

Specifies the host name of the virtual machine whose credentials are to be added, updated, or deleted. This option can be used only if the NetBackup Snapshot Client license key has been installed.

`-vm_type virtual_machine_type`

Specifies the type of virtual machine. The following are possible values:

1 - VMware Virtual Center Servers

2 - VMware ESX Servers

3 - VMware Converter Servers

This option can be used only if the NetBackup Snapshot Client license key has been installed.

`-vm_user_id user_id`

Specifies the user name that NetBackup must use to communicate with a virtual machine's disk array. This option can be used only if the NetBackup Snapshot Client license key has been installed.

`-update`

Changes the configuration information for a drive or robot. For example, you can add a drive to a robot.

`-user_id user ID`

Enables a user to configure a user name and password for all media servers and NDMP host combinations under a given master server. Use this option with the `-add`, `-update`, or `-delete` commands to specify the user name and password.

NOTES

The following paragraphs apply only to NetBackup Enterprise Server:

Configure all locally attached drives and robots on Windows by using the SCSI port, bus, target, and lun. Do this configuration regardless of whether an operating system device name (like `\\.\Changer0` or `\\.\Tape0`) is associated with the device.

If the robotic control is on a remote host, use the `-cntlhost` option.

The following paragraph applies only to NetBackup Server:

`tpconfig -d` may truncate drive names to 22 characters.

`tpconfig -l` may truncate drive names to 32 characters.

Use `tpconfig -dl` to obtain the full drive name.

You must have administrator privileges to run this command.

EXAMPLES

In the following examples, the command that is entered is shown on multiple lines because of page limitations. The actual command is entered on one line.

Example 1: Robotic control on the local Windows server

The following example adds a robot that connects directly to a Windows host, and also adds drives to that robot.

The following procedure applies only to NetBackup Server:

1 Add the robot by using the following command:

```
tpconfig -add -robot 7 -roptype tld -port 0 -bus 0  
-target 2 lun 0
```

2 If there are drives in the robot that have not been configured, add them.

The following command configures the drive with the system name of Tape0 under control of the robot that is configured in step 1. (The server has attached and recognized Tape0.)

```
tpconfig -add -drive -type dlt -port 1 -bus 2 -target 3  
-lun 4 -comment "DEC DLT2000 8414" -index 0 -drstatus  
up -robot 7 -roptype tld -robdrnum 1 -asciiname  
DLT2000_D1
```

The command in this example uses the comment field. This field is useful for storing the drive's SCSI inquiry data so that drive type and firmware level can be easily checked.

3 If the robot contains any drives that are currently configured as stand-alone drives, update the drive configuration to place them under robotic control.

The following commands update the configuration for drives 1 and 2:

```
tpconfig -update -drive 1 -type dlt -robot 7 -roptype tld  
-robdrnum 1  
tpconfig -update -drive 2 -type dlt -robot 7 -roptype tld  
-robdrnum 2
```

Note: Assign the correct robot drive number to the drives. If robot drive numbers are incorrect, tape mounts or backups may fail.

Example 2: Robotic control on the remote host

The following example applies only to NetBackup Enterprise Server:

This example adds a robot that connects to another host. It assumes that one or more tape drives that are in the robot, connect to the Windows host where you currently manage devices.

- 1 Add the robot by executing the following command:

```
tpconfig -add -robot 9 -robrtype tld -cnthost perch
Ensure that the robot number matches the one on the control host.
```

- 2 If the robot contains any drives that are currently configured as stand-alone, update the drive configuration to place them under robotic control.

The following commands update the configuration for drives 1 and 2:

```
tpconfig -update -drive 1 -type dlt -robot 9 -robrtype tld
-robrdrnum 1
tpconfig -update -drive 2 -type dlt -robot 9 -robrtype tld
-robrdrnum 2
```

Note: Assigned the correct robot drive number. If robot drive numbers are incorrect, tape mounts or backups may fail.

- 3 If there are drives in the robot that have not been configured, add them now. The following command configures the drive with the system name of Tape0 under control of the robot that is configured in step 1. (The Windows server has attached and recognized Tape0.)

```
tpconfig -add -drive -type dlt -port 1 -bus 2 -target 3
-lun 4 -comment 'DEC      DLT2000 8414' -index 3 -drstatus
up -robot 9 -robrtype tld -robrdrnum 3 -asciiname
DLT2000_D3
```

Example 3: Configuring new stand-alone drives

The following is an example of how to add a stand-alone drive after the drive is installed:

```
tpconfig -add -drive -type dlt -port 1 -bus 2 -target 3 -lun
4 -comment 'DEC      DLT2000 8414' -index 6 -asciiname
DLT2000_standalone
```

Example 4: Demonstrate how Windows displays device paths

This example demonstrates how to how the -l option displays the Windows device paths in the p, b, t, l format.

```
C:\Program Files\VERITAS\Volmgr\bin>tpconfig -l
```

Device Type	Robot Num	Drive Index	Robot Type	DrNum	Status	Comment	Drive Name	Device Path
robot	0	-	TLD	-	-	-	-	{3,1,0,1}
robot	1	-	TLD	-	-	-	-	{3,1,0,3}

```

robot      2    -    TLD      -    -    -    -    {3,1,2,0}
drive     -    0    pcd      -    DISABL -    SONY.SDX-400V.000 {1,0,0,0}
drive     -    1    hcart2  2    UP    -    IBM.ULTRIUM-TD2.001 {3,1,0,2}
drive     -    1    hcart2  2    UP    -    IBM.ULTRIUM-TD2.001 {3,1,1,2}
drive     -    2    hcart2  1    UP    -    IBM.ULTRIUM-TD2.002 {3,1,0,5}
drive     -    2    hcart2  1    UP    -    IBM.ULTRIUM-TD2.002 {3,1,1,5}
drive     -    3    hcart  1    DOWN  -    IBM.ULTRIUM-TD1.003 {3,1,0,6}
drive     -    3    hcart  1    UP    -    IBM.ULTRIUM-TD1.003 {3,1,1,6}
drive     -    4    hcart  2    UP    -    IBM.ULTRIUM-TD1.004 {3,1,0,7}
drive     -    4    hcart  2    UP    -    IBM.ULTRIUM-TD1.004 {3,1,1,7}
drive     -    5    hcart2  2    UP    -    IBM.ULTRIUM-TD2.005 {3,1,2,1}
drive     -    6    hcart2  1    UP    -    IBM.ULTRIUM-TD2.006 {3,1,2,2}
  
```

tpext

NAME

`tpext`—update EMM database with new versions of device mappings and external attribute files

SYNOPSIS

```
install_path\Volmgr\bin\tpext -loadEMM
```

DESCRIPTION

The `tpext` command updates the EMM database with new versions of the device mappings and external attribute files.

EXAMPLES

- 1 Before you repopulate this data, make sure that you have the most current support for new devices. New devices are added approximately every two months.
 - a Obtain the `external_types.txt` mapping file from <http://entsupport.symantec.com>.
 - b On the EMM server or the master server, place `external_types.txt` in `/usr/openv/var/global` to replace the current `external_types.txt` file.

- 2 Repopulate the EMM data by running the `tpext` utility:

```
install_path\Volmgr\bin\tpext -loadEMM
```

During regular installation, `tpext` is run automatically.

Caution: If you use the `create_nbdbcommand` to create a database manually, you must also run the `tpext` utility. `tpext` loads EMM data into the database.

tpreq

NAME

`tpreq`—request a tape volume for mounting and assign a file name to the drive

SYNOPSIS

```
install_path\Volmgr\bin\tpreq -m media_id [-a accessmode] [-d density] [-p  
poolname] [-f] filename
```

DESCRIPTION

This command initiates a mount request for a tape volume on a removable media device. The information that you specify with this command identifies and registers the specified file as a logical identifier for the mount request with Media Manager. It also manages access to the volume.

Media Manager automatically mounts the media if it is in a robotic drive. Otherwise, an operator mount request appears in the Device Monitor window. `tpreq` does not complete normally in the case of a mount request for a robotic drive, if operator intervention is required. These requests also appear in the Device Monitor window.

When the operation is complete, use the `tpunmount` command to remove the file name from the directory in which the file was created.

You must have administrator privileges to execute this command.

OPTIONS

`-m media_id`

Specifies the media ID of the volume to be mounted. You can enter the ID in upper or lowercase; Media Manager converts it to uppercase.

`-a accessmode`

Specifies the access mode of the volume. Valid access modes are `w` and `r`. If the access mode is `w` (write), the media must be mounted with write enabled. The default is `r` (read), which means the media may be write protected.

`-d density`

Specifies the density of the drive. This option determines the type of drive on which the tape volume is mounted. The default density is `dlt`.

Valid densities for NetBackup Enterprise Server are as follows:

4mm for 4-mm cartridge, 8mm for 8-mm cartridge, 8mm2 for 8-mm cartridge 2, 8mm3 for 8-mm cartridge 3, `dlt` for DLT cartridge, `dlt2` for DLT

cartridge 2, dlt3 for DLT cartridge 3, hcart for 1/2-inch cartridge, hcart2 for 1/2-inch cartridge 2, hcart3 for 1/2-inch cartridge 3, qscsi for 1/4-inch cartridge.

The following applies only to NetBackup Enterprise Server:

The half-inch cartridge densities (hcart, hcart2, and hcart3) can be used to distinguish between any supported half-inch drive types. However, tape requests can only be assigned to drives of the associated media type. For example, is assigns a tape request with density hcart2 that specifies a media ID with media type HCART2 to an hcart2 drive. Likewise, is assigns a tape request with density hcart specifies a media ID with media type HCART to an hcart drive. The same rules apply to the DLT densities (dlt, dlt2, and dlt3) and the 8MM densities (8mm, 8mm2, and 8mm3).

Valid densities for NetBackup Server are as follows:

4mm for 4-mm cartridge, 8mm for 8-mm cartridge, dlt for DLT cartridge, hcart for 1/2-Inch cartridge, qscsi for 1/4-inch cartridge.

The mount request must be performed on a drive type that satisfies the density.

`-p poolname`

Specifies the volume pool where the volume resides. *poolname* is case sensitive. The default is None.

`-f filename`

Specifies the file to be associated with the volume.

The file name can be a single name or a complete path. If you specify only a file name, the file is created in the current working directory. If you specify a path, the file is created in the directory that is named in the path. *filename* cannot be an existing file.

If the `tpreq` command is successful, Media Manager creates a file with the name that you specified. This file contains the name of the tape device where the media is mounted. Do not delete this file. Use the `tpunmount` command to remove it.

The specification of `-f` before *filename* is optional.

EXAMPLES

The following sample `tpreq` command reserves a tape drive and creates a symbolic tape file:

```
tpreq -f tape1 -m jlr01 -a w -d qscsi
```

This command creates a file named `tape1` in the current working directory. It links the file to the drive that contains the volume that has media ID of JLR01.

The access mode for the tape file is set to write, and a 1/4-inch cartridge drive is assigned.

tpunmount

NAME

`tpunmount`—remove a tape volume from a drive and a tape file from the directory

SYNOPSIS

```
install_path\Volmgr\bin\tpunmount [-f] filename [-force]
```

DESCRIPTION

`tpunmount` removes a tape file from the directory and physically removes the tape volume from the drive (if the media was mounted).

Stand-alone drives are *not* unloaded when the `DO_NOT_EJECT_STANDALONE` option is specified (and the `-force` option is *not* specified). This option is now stored in EMM.

The tape file and the device must be closed before you can use `tpunmount`.

You must have administrator privileges to run this command.

OPTIONS

`-f filename`

Specifies the file that is associated with the media. You must specify a file name. The specification of `-f` before *filename* is optional.

`-force`

Ejects the volume from a stand-alone drive, even if `DO_NOT_EJECT_STANDALONE` was specified in the EMM.

EXAMPLE

The following command unmounts the tape volume that is associated with file `tape1` and removes the file from the current directory:

```
tpunmount tape1
```

verifytrace

NAME

verifytrace - trace debug logs for verify job[s]

SYNOPSIS

```
install_path\NetBackup\bin\admincmd\verifytrace [-master_server name]  
-job_id number [-start_time hh:mm:ss] [-end_time hh:mm:ss] mmddy  
[mmddy _]
```

```
install_path\NetBackup\bin\admincmd\verifytrace [-master_server name]  
-backup_id id [-start_time hh:mm:ss] [-end_time hh:mm:ss] mmddy  
[mmddy _]
```

```
install_path\NetBackup\bin\admincmd\verifytrace [-master_server name]  
[-policy_name name] [-client_name name] [-start_time hh:mm:ss]  
[-end_time hh:mm:ss] mmddy [mmddy _]
```

DESCRIPTION

The `verifytrace` command consolidates the debug log messages for the specified verify job[s] and writes them to standard output. The messages sort by time. `verifytrace` attempts to compensate for time zone changes and clock drift between remote servers and clients.

At a minimum, you must enable debug logging for the following:

- The `install_path\NetBackup\bin\admin` directory on the master server
- The `bpbrm`, `bptm/bpdm`, and `tar` commands on the media server

For best results, set the verbose logging level to 5. Enable debug logging for `bpdbm` on the master server and `bpcd` on all servers and clients in addition to already identified processes.

If you specify either `-job_id` or `-backup_id`, `verifytrace` uses this option as the sole criteria for selecting the verify job[s] it traces. You cannot use the options `-policy_name` or `-client_name` with `-job_id` or `-backup_id`. If you do not specify `-job_id` or `-backup_id`, `verifytrace` selects all the verify jobs that match the specified selection criteria. If none of the following options is specified, `verifytrace` traces all the verify jobs that ran on the days that the day stamps (*mmddy*) specify: `-job_id`, `-backup_id`, `-policy_name`, or `-client_name`. If `-start_time`/`-end_time` options are used, the debug logs in the specified time interval are examined.

If `verifytrace` is started with `-backup_id id`, it looks for a verify job that `bpverify` started with `-backup_id id` where the backup IDs (*id*) match.

If `verifytrace` is started with `-policy_name name`, it looks for a verify job that `bpverify` started with `-policy_name name` where the policy names (*name*) match.

If `verifytrace` is started with `-client_name name`, it looks for a verify job that `bpverify` started with `-client_name name` where the client names (*name*) match.

`verifytrace` writes error messages to standard error.

You must have administrator privileges to run this command.

OPTIONS

`-master_server`

Name of the master server. Default is the local host name.

`-job_id`

Job ID number of the verify job to analyze. Default is any job ID.

`-backup_id`

Backup ID number of the backup image that the verify job verified to analyze. Default is any backup ID.

`-policy_name`

Policy name of the verify jobs to analyze. Default is any policy.

`-client_name`

Client name of the verify jobs to analyze. Default is any client.

`-start_time`

Earliest time stamp to start analyzing the logs. Default is 00:00:00.

`-end_time`

Latest time stamp to finish analyzing the logs. Default is 23:59:59.

`mmddy`

One or more "day stamps". This option identifies the log file names (log.mmddy for UNIX, mmddy.log for Windows) that are analyzed.

OUTPUT FORMAT

The format of an output line is:

```
<daystamp>.<millisecs>.<program>.<sequence> <machine>  
<log_line>
```

daystamp

The day of the log in `yyyymmdd` format.

milliseconds
The number of milliseconds since midnight on the local machine.

program
The name of program (ADMIN, BPBRM, BPCD, etc.) being logged.

sequence
Line number within the debug log file.

machine
The name of the NetBackup server or client.

log_line
The line that appears in the debug log file.

EXAMPLES

Example 1

The following example analyzes the log of verify job with job ID 2 that ran on August 6, 2002.

```
verifytrace -job_id 2 080602
```

Example 2

The following example analyzes the verify jobs log that verify backup images with backup ID *pride_1028666945*, which ran on *20th August 2002*. This command only analyzes those verify jobs that were ran with option *-backupid pride_1028666945*.

```
verifytrace -backup_id pride_1028666945 082002
```

Example 3

The following example analyzes the verify jobs log that was ran on policy *Pride-Standard* and client *pride* on August 16, 2002 and August 23, 2002. This command only analyzes those verify job that were ran with options *-policy Pride-Standard* and *-client pride*.

```
verifytrace -policy_name Pride-Standard -client_name pride  
081602 082302
```

Example 4

The following example analyzes the verify jobs log that ran on August 5, 2002 and August 17, 2002.

```
verifytrace 080502 081702
```

vltcontainers

NAME

vltcontainers - move volumes logically into containers

SYNOPSIS

```
install_path\NetBackup\bin\vltcontainers
-run [-rn robot_number]
-run -usingbarcodes [-rn robot_number]
-run -vltcid container_id -vault vault_name -sessionid session_id
-run -vltcid container_id -f file_name [-rn robot_number] [-usingbarcodes]
-view [-vltcid container_id]
-change -vltcid container_id -rd return_date
-delete -vltcid container_id
-version
```

DESCRIPTION

vltcontainers logically adds the media that was ejected from one or more vault sessions to containers. vltcontainers also can view, set, or change the return date of containers that go off-site or are already at the off-site vault. vltcontainers can delete a container from the NetBackup and Media Manager catalogs.

You can add media IDs to containers as follows:

- Use the keyboard to enter the container and the media IDs.
- Use a keyboard interface bar code reader to scan the container IDs and media IDs. Keyboard interface readers are also known as keyboard *wedge* readers because they connect (or wedge) between the keyboard and the keyboard port on your computer.
- Use an input file that contains the media IDs or numeric equivalents of bar codes of all the media that are added to one container. To add media to more than one container, enter the IDs by using the keyboard or a keyboard interface bar code reader. Or the vltcontainers command again and specify different container and filename options.

- Add all the media that a specific session ejects to one container. To add media from a single eject session into more than one container, enter IDs using the keyboard or a keyboard interface bar code reader.

The `vltcontainers` command must be ran from a NetBackup master server that is licensed for Vault.

If the following directory with public-write access exists, `vltcontainers` write to the daily debug log file (`log.DDMMYY` where `DDMMYY` is current date) in the following directory:

```
install_path\netbackup\logs\vault
```

Public-write access is required because not all executable files that write to this file can run as administrator or root user.

OPTIONS

`-change`

Changes the default return date for the container. The default return date of a container is the date of the volume in the container that is returned the latest. Requires the `-vltcid container_id` option and argument.

`-delete`

Deletes the container record from the NetBackup and Media Manager catalogs. You can delete a container only if it contains no media. Requires the `-vltcid container_id` option and argument.

`-f file_name`

Specifies the file from which to read media IDs. All the listed media in the file is added to the container that the `-vltcid` option specifies. The file can be a list of media IDs (one per line). Or it can be the numeric equivalents of bar codes (one per line) scanned into a file by a bar code reader.

`-rd return_date`

Specifies the return date for the container. The return date format depends on the locale setting.

`-rn robot_number`

Specifies the robot, which is used to determine the EMM Server from which the `vltcontainers` command should obtain media information. If `-rn robot_number` is not used, the master server is considered as the EMM server. The only media that can be added to containers is the media in the database on the EMM server.

`-run`

Logically adds media to the container. If you specify no other options, you must enter the container IDs and the media IDs by using the keyboard. To use a bar code reader to scan the container and the media IDs, specify the

`-usingbarcodes` option. To add the media that a specific session ejects, use the `-vault vault_name` and `-sessionid session_id` options. To add the media that is specified in a file, use the `-f file_name` option. To specify an EMM server other than the master server, use the `-rn robot_number` option.

`-sessionid session_id`

The ID of a vault session. All media that the specified session ejects is added to the container that the `-vltcid` option specifies.

`-usingbarcodes`

Specifies the following: a keyboard interface bar code reader scans container IDs and media IDs, or bar code numbers are used in the file that `-f file_name` specifies. Keyboard interface bar code readers (also called keyboard wedge bar code readers) connect between the keyboard and the keyboard port on your computer.

`-vault vault_name`

The name of the vault to which the profile that ejected the media belongs. You also must specify the ID of the session (`-sessionid`) that ejected the media to be added to the container.

`-version`

Display the `vltcontainers` version and exit.

`-view [-vltcid container_id]`

Shows the return date that is assigned to all containers. Use the `-vltcid container_id` option and argument to show the return date of a specific container.

`-vltcid container_id`

Specifies the container ID. Container ID can be a string of up to 29 alphanumeric characters (no spaces). The `-rd return_date` option and argument are required to change a container return date.

EXAMPLES

Example 1

Use the following command to:

- Add the volumes that are ejected from robot number 0 to containers
- Use a bar code reader to scan the container ID and media ID

```
vltcontainers -run -usingbarcodes -rn 0
```

Example 2

To view the return date of container ABC123, use the following command:

```
vltcontainers -view -vltcid ABC123
```

Example 3

To change the return date of container ABC123 to December 07, 2004, use the following command:

```
vltcontainers -change -vltcid ABC123 -rd 12/07/2004
```

Example 4

To delete container ABC123 from the NetBackup and Media Manager catalogs, use the following command:

```
vltcontainers -delete -vltcid ABC123
```

Example 5

To add all media that was ejected to container ABC123 by session 4 of vault MyVault_Cntrs, use the following command:

```
vltcontainers -run -vltcid ABC123 -vault MyVault_Cntrs  
-sessionid 4
```

Example 6

To add the media that is listed in the `medialist` file that are ejected from robot number 0 to container ABC123, use the following command:

```
vltcontainers -run -vltcid ABC123 -f C:\home\jack\medialist  
-rn 0
```

Example 7

Use the following command to:

- Add media to container ABC123 that was ejected from a robot that is attached to the master server
- Read the bar codes for that media from the `medialist` file

```
vltcontainers -run -vltcid ABC123 -f C:\home\jack\medialist  
-usingbarcodes
```

RETURN VALUES

Vault may exit with a status code greater than 255. Such status codes are called extended exit status codes. For such a case, the exit status that returned to the system is 252. The actual exit status is written to `stderr` in the format `EXIT status = exit status`

The extended exit status values are documented in the *NetBackup Troubleshooting Guide for UNIX and Windows* and in the *NetBackup Troubleshooting Wizard*.

FILES

```
install_path\NetBackup\vault\sessions\cntrDB
```

```
install_path\NetBackup\db\vault\vault.xml  
install_path\netbackup\logs\vault
```

NOTES

The format that you use for date and time option values varies according to your locale setting. The examples in this command description are for a locale setting of C.

SEE ALSO

vltadm, vltoffsitemedia, vltopmenu

vlteject

NAME

vlteject - eject media and generate reports for previously run sessions

SYNOPSIS

The syntax for the command is:

```
install_path\NetBackup\bin\vlteject
-eject [-profile profile_name] [-robot robot_name] [-vault vault_name
      [-sessionid id]] [-auto y|n] [-eject_delay seconds]
-report [-profile profile_name] [-robot robot_name] [-vault vault_name
      [-sessionid id]] [-legacy]
-eject -report [-profile profile_name] [-robot robot_name] [-vault
      vault_name [-sessionid id]] [-auto y|n] [-eject_delay seconds]
      [-version] [-legacy]
-preview [-profile profile_name] [-robot robot_name] [-vault vault_name
      [-sessionid id]]
```

DESCRIPTION

vlteject ejects media and generates the corresponding reports (as configured in the profiles) for vault sessions for which media have not yet been ejected.

vlteject can process the pending ejects and reports for all sessions, for a specific robot, for a specific vault, or for a specific profile. To process all pending ejects and reports, do not use the `-profile`, `-robot`, or `-vault` option.

vlteject operates only on sessions for which the session directory still exists. After that directory is cleaned up (removed by NetBackup), vlteject can no longer eject or report for that session.

Depending on how it is called it can run interactively or not. Run interactively when you plan to eject more media than that amount that fits in the media access port.

Do not modify your vault configuration while vlteject is running.

vlteject can be run in any of the following ways:

- Directly from the command line
- By using the NetBackup policy schedule. The policy must be of type Vault, and the policy's file list must consist of a vlteject command.

- By using `vltopmenu` to run an eject operation or a consolidated eject or consolidated report operation

If the following directory exists and has public-write access, `vlt eject` writes to the daily debug log file:

```
install_path\NetBackup\logs\vault\
```

The daily debug log file is `log.DDDMMYY`; the `DDMMYY` is the current date.

Public-write access is required because not all executable files that write to this file can run as administrator or root user. The host property **Keep vault logs for *n* days** determines how long the vault session directories are retained.

Any authorized user can run this command.

For more information about NetBackup authorization, refer to the *NetBackup Security and Encryption Guide*.

OPTIONS

`-auto y|n`

Specifies automatic (y) or interactive mode (n). In automatic mode (y), `vlt eject` runs without input from the user and does not display output. In interactive mode (n - the default), `vlt eject` runs interactively. It accepts input and displays output.

`-eject`

Eject media for the indicated sessions. `-eject` is optional if eject was completed and you only want to generate reports.

`-eject_delay seconds`

The number of seconds to delay before ejecting. This option is useful if an operation such as backing up or duplication recently occurred on the affected media. The default is 0. The maximum is 3600 (one hour).

`-help`

Displays a synopsis of command usage when it is the only option on the command line.

`-legacy`

Generates reports by using the old-style consolidation. Valid only with the `-report` option.

`-preview`

Lists the sessions and the media that are ejected for the sessions. Does not eject the media.

`-profile profile_name`

The name of a profile or a robot number, vault, and profile for which to eject media and generate reports. If `profile` is used without `robot` and `vault`, the

profile must be unique. To process all pending ejects and reports, do not use the `-profile`, `-robot`, or `-vault` option.

`-report`

Generate reports for the indicated sessions. If the corresponding eject process has completed, it generates and distributes any pending reports from the selected sessions. The reports are not generated again if `vlt eject` is run again. If eject has not completed, the subset of reports that do not depend on completion of eject are generated. These reports are generated again if `vlt eject -report` is run again after eject has completed.

`-robot robot_name`

The robot for which to eject media and generate reports. All vaults in the robot should use the same off-site volume group. To process all pending ejects and reports, do not use the `-profile`, `-robot`, or `-vault` option.

`-sessionid id`

The numeric session ID. If `-profile`, `-robot`, or `-vault` is specified, but `-session id` is not specified, `vlt eject` operates on all sessions for the specified profile, robot, or vault.

`-vault vault_name`

The vault for which to eject media and generate reports. To process all pending ejects and reports; do not use the `-profile`, `-robot`, or `-vault` option.

`-version`

Display the `vlt eject` version and exit.

EXAMPLES

Example 1

To eject media and generate reports for all robots that have sessions for which media have not yet been ejected, enter the following:

```
vlt eject -eject -report
```

Example 2

To eject all media that have not yet been ejected for all sessions for the CustomerDB vault and to generate corresponding reports, enter the following:

```
vlt eject -vault CustomerDB -eject -report
```

RETURN VALUES

Vault may exit with a status code greater than 255. Such status codes are called extended exit status codes. For such a case, the exit status that is returned to the

system is 252. The actual exit status is written to `stderr` in the format, `EXIT status = exit status`

The extended exit status values are documented in the *NetBackup Troubleshooting Guide for UNIX and Windows* and in the *NetBackup Troubleshooting Wizard*.

FILES

```
install_path\NetBackup\db\vault\vault.xml  
install_path\NetBackup\logs\bpbrm\vt\mmdyy.log  
install_path\NetBackup\logs\vault\mmdyy.log  
install_path\NetBackup\vault\sessions\vault_name\sidxxx\detail.log  
install_path\NetBackup\vault\sessions\vault_name\sidxxx\summary.log  
install_path\NetBackup\vault\sessions\vault_name\sidxxx\vlteject.status  
install_path\NetBackup\vault\sessions\vlteject.mstr  
install_path\NetBackup\bp.conf
```

SEE ALSO

vltopmenu

vltinject

NAME

vltinject - inject volumes into a robot for a specified vault configuration

SYNOPSIS

```
install_path\NetBackup\bin\vltinject profile|robot/vault/profile  
[-version]
```

DESCRIPTION

vltinject injects volumes into a robot and updates the Enterprise Media Manager Database. It runs `vmupdate` and assigns it the robot number, robot type, and robotic volume group from the vault configuration that matches the specified profile.

If the following directory exists and has public-write access, vltinject writes to the daily debug log file:

```
install_path\NetBackup\logs\vault\
```

The daily debug log file is `log.DDMYY`; the `DDMMYY` is the current date.

You then can use this file for troubleshooting. Public-write access is needed because not all executables that write to this file can run as administrator or root.

Any authorized user can run this command.

For more information about NetBackup authorization, refer to the *NetBackup Security and Encryption Guide*.

OPTIONS

```
profile|robot/vault/profile
```

The name of a profile or a robot number, vault, and profile that are nested within the vault configuration file. If `profile` is used without `robot` and `vault`, the profile must be unique. vltinject executes `vmupdate` with the robot number, robot type, and robotic volume group from this profile's configuration.

```
-version
```

Display the vltinject version and exit.

EXAMPLE

Example 1

To inject the volumes that the Payroll profile has vaulted and that were returned from the off site vault, enter the following:

```
vltinject Payroll
```

Example 2

To inject the volumes that the Weekly profile (in the Finance vault) vaulted and that the off site vault has returned, the user enters the following:

```
vltinject 8/Finance/Weekly
```

RETURN VALUES

0 The EMM Database was successfully updated.

not = 0 There was a problem updating the EMM Database.

Vault may exit with a status code greater than 255. Such status codes are called extended exit status codes. For such a case, the exit status that is returned to the system is 252. The actual exit status is written to `stderr` in the format, `EXIT status = exit status`

The extended exit status values are documented in the NetBackup *Troubleshooting Guide* and in the NetBackup *Troubleshooting Wizard*.

FILES

```
install_path\NetBackup\logs\vault\mmdyy.log
```

vloffsitemedia

NAME

vloffsitemedia - list off site parameter values for a group of media, or change the off site parameter value for a single media

SYNOPSIS

```
install_path\NetBackup\bin\vloffsitemedia -list [-W] [-vault vault_name]
[-voldbhost host_name]

install_path\NetBackup\bin\vloffsitemedia -change -m media_id
[-voldbhost host_name] [-d media_description] [-vltname vault_name]
[-vltsent date] [-vltreturn date] [-vltslot slot_no] [-vltcid
container_id] [-vltsession session_id]

install_path\NetBackup\bin\vloffsitemedia -version
```

DESCRIPTION

Allows the user to change the vault-specific parameters of a given media. This command lets the user change one or more parameters by using a single command. It lets the user view the various vault parameters of all media for a particular EMM server or vault.

If you create the following directory with public-write access, vloffsitemedia creates a daily debug log in this directory:

UNIX: /usr/openv/netbackup/logs/vault

Windows: install_path\netbackup\logs\vault

The log is called log.DDMYY (where *DDMMYY* is the current date). You then can use this file that for troubleshooting.

OPTIONS

-change

Change the attributes of the specified volume.

-d *media_description*

Specifies the description for the volume.

To configure NetBackup so that the media description field is cleared automatically when volumes are returned to the robot, set the VAULT_CLEAR_MEDIA_DESC parameter in EMM.

-list

Lists the off-site parameters for the media in the local EMM database. To restrict the list to a specific vault for the local EMM database, include the -vault option with the command. To list the off-site parameters for media for a specific EMM database, include the -voldbhost option with the command.

-m media_id

Media ID of the volume whose vault parameters are to be changed.

-vault vault_name

Name of the vault for which all media IDs and their vault-specific parameters are to be listed.

-version

Display the vloffsitemedia version and exit.

-vltcid container_id

Specifies the container in which a volume is stored. *container_id* (a string of up to 29 alphanumeric characters (no spaces)) specifies the new container for the volume. You must specify an existing container ID. You cannot assign media from one EMM server to a container that has media from a different EMM server. Use the -m option to specify the media ID of the volume.

-vltname vault_name

Specifies the name of the logical vault that is configured for the robot that ejected the volume.

-vltreturn date

Specifies the date and time the media was requested for return from the vault vendor. For Catalog Backup volumes, this date is the date that the media is requested for return from the vault vendor.

The format of *date* depends on the user's locale setting. See the NOTES section for more information. For the C locale, the date syntax is as follows:

mm/dd/yyyy [hh[:mm[:ss]]]

-vltsent date

Specifies the date and time the media was sent to the off site vault.

The format of *date* depends on the user's locale setting. See the NOTES section for more information. For the C locale, the date syntax is as follows:

mm/dd/yyyy [hh[:mm[:ss]]]

-vltsession session_id

Specifies the identifier of the Vault session that ejected this media.

`-vltslot slot_no`

Specifies the vault vendor's slot number for the slot that this volume occupies.

`-voldbhost host_name`

Name of the EMM server.

`-w`

Specifies the parsable output format for the media off-site parameters. For containers, the output includes the length of the container description, the container description, and the container ID. The output header line is a space that is separated line of column labels; the output data lines are space separated fields.

EXAMPLES

Example 1

The following command changes the vault name and the vault sent dates of the media with the ID BYQ123:

```
vltffsitemedia -change -m BYQ123 -vltname THISTLE -vltsent
08/01/2003 12:22:00
```

Example 2

The following command changes the vault slot number to 100 for a media with ID 000012:

```
vltffsitemedia -change -m 000012 -vltslot 100
```

Example 3

The following command can be used to clear out the vault-specific fields for a media:

```
vltffsitemedia -change -m 000012 -vltname "" -vltsession 0
-vltslot 0 -vltsent 0 -vltreturn 0
```

or:

```
vltffsitemedia -change -m 000012 -vltname - -vltsession 0
-vltslot 0 -vltsent 00/00/00 -vltreturn 00/00/00
```

Example 4

To change the container ID and media description of volume ABC123:

```
vltffsitemedia -change -m ABC123 -vltcid Container001 -d
"Media Added By Jack"
```

Example 5

To clear the container ID and media description of volume ABC123:

```
vltffsitemedia -change -m ABC123 -vltcid - -d ""
```

or:

```
vltoffsitemedia -change -m ABC123 -vltcid "" -d ""
```

The `vltoffsitemedia` command uses the Media Manager commands to query or update the EMM database.

If the `vltoffsitemedia` command fails, look at the debug log in the following directory for detailed information about the actual Media Manager command that failed:

```
install_path\netbackup\logs\vault\
```

For more information on the status codes that Media Manager commands return, see the NetBackup *Troubleshooting Guide*, Chapter 5, Media Manager Status Codes and Messages.

RETURN VALUES

Vault may exit with a status code greater than 255. Such status codes are called "extended exit status codes." For such a case, the exit status that is returned to the system is 252. The actual exit status is written to `stderr` in the format, `EXIT status = exit status`

The extended exit status values are documented in the NetBackup *Troubleshooting Guide* and in the NetBackup Troubleshooting Wizard.

NOTES

The format that you use for date and time option values varies according to your locale setting. The examples in this command description are for a locale setting of C.

vltopmenu

NAME

vltopmenu - start NetBackup Vault menu interface for operators

SYNOPSIS

```
install_path\NetBackup\bin\vltopmenu [-version]
```

DESCRIPTION

Allows the user to activate a menu screen that contains the various options that an Operator of the NetBackup Vault feature can use. It lets the user eject or inject media, print various reports individually or collectively. It also consolidates all reports and ejects for all sessions that have not ejected media yet. This interface can be used from any character-based terminal (or terminal emulation window) for which the user has a termcap or a terminfo definition.

See the NetBackup *Operator's Guide* for detailed operating instructions.

Any authorized user can run this command.

For more information about NetBackup authorization, refer to the *NetBackup Security and Encryption Guide*.

OPTIONS

-version

Display the vltopmenu version and exit.

RETURN VALUES

Vault may exit with an extended exit status codes (greater than 255). For such a case, the exit status is returned to the system is 252. The actual exit status is written to `stderr` in the format, `EXIT status = exit status`

The extended exit status values are documented in the NetBackup *Troubleshooting Guide* and in the NetBackup *Troubleshooting Wizard*.

FILES

```
install_path\NetBackup\vault\sessions\vlteject.mstr
```

```
install_path\NetBackup\vault\sessions\vlteject_status.log.timestamp
```

```
install_path\NetBackup\vault\sessions\*\sid*\detail.log
```

vltrun

NAME

vltrun - Run a NetBackup Vault session

SYNOPSIS

```
install_path\NetBackup\bin\vltrun -halttdups -vjobs vault_jobid [profile |  
robot/vault/profile] [-preview] [-verbose | -v] [-version] [-help]
```

DESCRIPTION

vltrun drives a NetBackup Vault session by issuing a sequence of calls to the vault engine. Optionally, the session can include callouts to user-provided notify scripts.

OPTIONS

profile | *robot/vault/profile*

Specifies the name of a profile or a nested robot number, vault, and profile in the vault parameter file. If *profile* is used without *robot* and *vault*, the profile must be unique within the vault parameter file. This option is required.

-vjob *vault_jobid*

Specifies the job ID of an active vault job that is currently being duplicated.

-halttdups

Terminates all associated, active vault duplication jobs.

-preview

Generates the preview list of images to be vaulted in a vault session. The results go to the file `preview.list` in the session directory.

-verbose | -v

Reports verbosely on the session in the vault debug log.

-version

Displays the vltrun version and exit.

-help

Displays a synopsis of command usage when it is the only option on the command line.

USAGE

The `vlt-run` session follows this sequence:

- Run the `vlt_start_notify` script
- Inventory media
- Initialize Media Manager database for vault media returned to the robot
- Generate the list of preview images to be vaulted
- Duplicate images
- Inventory Media Manager database (first time)
- Assign media for the NetBackup catalog backup
- Inventory Media Manager database (second time)
- Inventory images
- Suspend media
- Run the `vlt_end_notify` script
- Re-inventory images
- Assign slot IDs
- Backup the NetBackup catalog
- Inventory the Media Manager database (third and final time)
- Run the `vlt_ejectlist_notify` script
- Generate the eject list
- Run the `vlt_starteject_notify` script
- Eject and report
- Run the `vlt_end_notify` script

`vlt-run` can be run in any of the following ways:

- directly from the command line;
- by NetBackup policy scheduling. In this case, the policy must consist of type Vault, and the policy's file list must consist of a `vlt-run` command;
- by running the command `Start Session` for a profile in the Vault GUI or `vltadm`.

`vlt-run` uses the option `profile|robot/vault/profile` to run a vault session. You can use the `profile` form of the option if there is no other profile with the same name in your vault configuration. In this case, the profile name is sufficient to uniquely identify the configuration information.

If there is more than one profile with the same name, then use the *robot/vault/profile* form to uniquely identify the configuration.

Do not modify your vault configuration while a vault session is running.

When the session starts, it creates a directory to hold the files created by vltrun and the vault engine during the session.

The vault session uses the following directory:

```
install_path\NetBackup\vault\sessions\vault_name\sidxxx
```

The *xxx* variable is an integer uniquely assigned to this session. For each vault name, session identifiers are sequentially assigned, starting with 1.

If you have configured an email address in your vault properties, then email will be sent to this address at the end of the session, reporting the results. By default, email is sent to root.

vltrun produces an overview of the session, called `summary.log`, in the session directory.

You can control vault processing at several points in the session by installing notify scripts in the directory for NetBackup binaries, `/usr/openv/netbackup/bin`. Refer to the *NetBackup Vault Administrator's Guide* for more information on notify scripts.

You can monitor the progress of your vltrun session in the NetBackup Activity Monitor. The Operation field on the main Activity Monitor window shows the progress of your vault session:

- Choosing Images
- Duplicating Images
- Choosing Media
- Catalog Backup
- Eject and Report
- Done

If you create the following directory with public-write access, vltrun creates a daily debug log in this directory:

```
UNIX: /usr/openv/netbackup/logs/vault
```

```
Windows: install_path\netbackup\logs\vault
```

The log is called `log.DDMMYY` (where *DDMMYY* is the current date). You then can use this file that for troubleshooting.

Public-write access is needed because not all executables that write to this file run as administrator or root.

You can adjust the level of logging information provided in this log file by adjusting the vault logging level parameter on the **Logging** page of the master server's properties via **Host Properties** on the NetBackup Console.

You can terminate active vault duplication jobs by using the `vltrun -haltdups` command. Initiating a `-haltdups` script sends a SIGUSR2 signal to the main vault job (currently at the duplication step) and then automatically propagates the signal to all of the vault duplication instances without waiting for any current duplication job instance to finish. After this step completes, the main vault job proceeds with the remaining steps.

After the SIGUSR2 signal is received, the job details of the following message of the terminated vault duplication job appears:

termination requested by administrator (150)

You must have administrator privileges to run this command.

EXAMPLES

Example 1

To vault the profile `my_profile`, enter:

```
vltrun my_profile
```

Example 2

The following command vaults the images for robot 0, vault Financials, and profile Weekly:

```
vltrun 0/Financials/Weekly
```

Example 3

To terminate an active vault duplication job with the ID of 1, enter:

```
vltrun -haltdups -vjob 1
```

RETURN VALUES

Vault may exit with a status code greater than 255. Such status codes are called extended exit status codes. For such a case, the exit status returned to the system is 252, and the actual exit status is written to `stderr` in the format, `EXIT status = exit status`

The extended exit status values are documented in the NetBackup *Troubleshooting Guide* and in the NetBackup *Troubleshooting Wizard*.

FILES

```
install_path\NetBackup\vault
```

```
install_path\NetBackup\bp.conf
```

```
install_path\NetBackup\logs\bpbrm\vt\mmddyy.log  
install_path\NetBackup\logs\bpcd\mmddyy.log  
install_path\NetBackup\logs\vault\mmddyy.log  
install_path\NetBackup\db\vault\vault.xml  
install_path\NetBackup\vault\sessions\vault_name\sidxxx  
install_path\NetBackup\vault\sessions\vault_name\sidxxx\summary.log  
install_path\NetBackup\vault\sessions\vault_name\sidxxx\detail.log
```

SEE ALSO

vltadm, vlteject, vltinject, vltoffsitemedia, vltopmenu

vmadd

NAME

vmadd - add volumes to EMM database

SYNOPSIS

```
install_path\Volmgr\bin\vmadd -m media_id -mt media_type [-h EMM_server |  
volume_database_host] [-verbose] [-b barcode] [-rt robot_type] [-rn  
robot_number] [-rh robot_host] [-rc1 rob_slot] [-rc2 rob_side] [-p  
pool_number] [-mm max_mounts | -n cleanings] [-op optical_partner] [-d  
"media_description"]
```

DESCRIPTION

Add volumes to the Enterprise Media Manager (EMM) Database.

Any authorized user can run this command.

For more information about NetBackup authorization, refer to the *NetBackup Security and Encryption Guide*.

OPTIONS

`-m media_id`

Specifies the media ID of the volume to add. The media ID can be a maximum of 6 ASCII characters. The actual character input is restricted to alpha numerics and '.', '+', '_', and '-' if they are not the first character.

The following applies only to NetBackup Enterprise Server:

If you add an optical disk, specify the media ID for the A side of the optical platter. Media IDs for an API robot type (ACS, TLH, TLM, or) must always match the barcodes.

`-mt media_type`

Specifies the media type of the volume to add.

Valid media types for NetBackup Enterprise Server are as follows:

4mm, 8mm, 8mm2, 8mm3, dlt, dlt2, dlt3, dtf, hcart, hcart2, hcart3, odiskwm, odiskwo, qcart, 4mm_clean, 8mm_clean, 8mm2_clean, 8mm3_clean, dlt_clean, dlt2_clean, dlt3_clean, dtf_clean, hcart_clean, hcart2_clean, hcart3_clean

Valid media types for NetBackup Server are as follows:

4mm, 8mm, dlt, hcart, qcart, 4mm_clean, 8mm_clean, dlt_clean, hcart_clean

-h *EMM_server* | *volume_database_host*

This option is only applicable for NetBackup Enterprise Server.

The name of the Enterprise Media Manager database host that contains information about volumes. If no host is specified, the configured EMM server is used by default. For communicating with pre-NetBackup 6.0 systems not in the EMM domain, this server is the EMM server.

For systems before NetBackup 6.0, ensure the following: the specified host matches the EMM server name that is associated with the robot or set of stand-alone drives, as indicated in the device configuration.

-verbose

Selects the verbose mode.

-b *barcode*

Specifies the barcode that is attached to the volume.

-rt *robot_type*

Specifies the robot type of the robot where the volume is located.

Valid robot types for NetBackup Enterprise Server are as follows:

none, acs, odl, tl4, tl8, tld, tlh, tlm, tsh.

Valid robot types for NetBackup Server are as follows:

none, tl4, tl8, tld.

-rn *robot_number*

Unique, logical identification number for the robot where the volume is located.

-rh *robot_host*

Name of the host that controls the robot, where the volume is located.

-rc1 *rob_slot*

Robot coordinate 1 is the slot number in the robot where the volume is located.

The following applies only to NetBackup Enterprise Server:

Do not enter slot information for Media Manager API robot types. The robot software tracks the slot locations for these robots.

-rc2 *rob_side*

This option is only applicable for NetBackup Enterprise Server.

Robot coordinate 2 is the platter side for optical disks (A or B).

-p *pool_number*

Index of the volume pool that contains this volume. You can use `vmppool -listall` to determine the index for a given pool name.

`-mm max_mounts`

Maximum number of mounts allowed for this volume. Only used for non-cleaning media. When this limit is exceeded, the volume can be mounted for read operations only.

`-n cleanings`

The number of cleanings that remain for this volume. Only used for cleaning media.

`-op optical_partner`

This option is only applicable for NetBackup Enterprise Server.

If this disk is an optical disk, specify the media ID of the opposite side of the optical platter.

`-d "media_description"`

Media description of the volume. The double quote marks are required if the description contains any spaces.

EXAMPLES

The following command adds volume AJU244 in the NetBackup volume pool to the EMM database on the host that is named llama.

The volume has the barcode AJU244 and is in slot 2 of TLD robot 1. For write operations, the volume may be mounted a maximum of 1000 times.

The following point applies only to NetBackup Server:

Only one host (the master) exists , so the `-h` option is not needed.

Note: This command is usually entered on only one line.

```
vmadd -m AJU244 -mt dlt -h llama -b AJU244 -rt tld -rn 1 -rh  
llama -rc1 2 -p 1 -mm 1000 -d "vmadd example"
```

NOTES

Only limited validation of the option parameters is done.

SEE ALSO

`vmchange`, `vmdelete`, `vmpool`, `vmquery`

vmchange

NAME

vmchange - change media information in EMM database

SYNOPSIS

Change volume group residence

```
install_path\Volmgr\bin\vmchange [-h EMM_server | volume_database_host]  
-vg_res -rt robot_type -rn robot_number -rh robot_control_host -v  
volume_group
```

Change volume residence

```
install_path\Volmgr\bin\vmchange [-h EMM_server | volume_database_host]  
-res -m media_id -mt media_type -rt robot_type -rn robot_number -rh  
robot_control_host -v volume_group -rc1 rob_slot [-rc2 rob_side]
```

Change volume expiration date

```
install_path\Volmgr\bin\vmchange [-h EMM_server | volume_database_host]  
-exp date -m media_id
```

Change the barcode for a volume

```
install_path\Volmgr\bin\vmchange [-h EMM_server | volume_database_host]  
-barcode barcode -m media_id [-rt robot_type]
```

Change the container ID for a volume by media ID

```
install_path\Volmgr\bin\vmchange [-h EMM_server | volume_database_host]  
-m media_id -vltcid vault_container_id
```

Change the container ID for a volume by bar code

```
install_path\Volmgr\bin\vmchange [-h EMM_server | volume_database_host]  
-barcode barcode -vltcid vault_container_id
```

Change the media description for a volume

```
install_path\Volmgr\bin\vmchange [-h EMM_server | volume_database_host]  
-d "media_description" -m media_id
```

Associate this volume with a different pool

```
install_path\Volmgr\bin\vmchange [-h EMM_server | volume_database_host]  
-p pool_number -m media_id
```

Change a volume's maximum mount count

```
install_path\Volmgr\bin\vmchange [-h EMM_server | volume_database_host]  
-maxmounts max_mounts -m media_id
```

Change a volume's number of cleanings

```
install_path\Volmgr\bin\vmchange [-h EMM_server | volume_database_host]
-clean cleanings left -m media_id
```

Change a volume's number of mounts count

```
install_path\Volmgr\bin\vmchange [-h EMM_server | volume_database_host]
-n num_mounts -m media_id
```

Change a volume's media type

```
install_path\Volmgr\bin\vmchange [-h EMM_server | volume_database_host]
-new_mt media_type -m media_id
```

Change a volume's robot type

```
install_path\Volmgr\bin\vmchange [-h EMM_server | volume_database_host]
-new_rt robot_type -m media_id -rn robot_number
```

Change a volume's group

```
install_path\Volmgr\bin\vmchange [-h EMM_server | volume_database_host]
-new_v volume_group [-m media_id |{-b barcode -mt media_type -rt
robot_type}]
```

Change a volume's vault name

```
install_path\Volmgr\bin\vmchange [-h EMM_server | volume_database_host]
-vltname vault_name -m media_id
```

Change the date the volume was sent to the vault

```
install_path\Volmgr\bin\vmchange [-h EMM_server | volume_database_host]
-vltsent date -m media_id
```

Change the date when the volume returns from the vault

```
install_path\Volmgr\bin\vmchange [-h EMM_server | volume_database_host]
-vltreturn date -m media_id
```

Change a volume's vault slot number

```
install_path\Volmgr\bin\vmchange [-h EMM_server | volume_database_host]
-vltslot vault_slot -m media_id
```

Change the volume's vault session id

```
install_path\Volmgr\bin\vmchange [-h EMM_server | volume_database_host]
-vltsession vault_session_id -m media_id
```

Move (eject) volumes from an ACS, TLH, or TLM robot to stand-alone

```
install_path\Volmgr\bin\vmchange -api_eject -map map_id:mapid:...:mapid /
any -w [-h EMM_server | volume_database_host] -res -ml
media_id:media_id: ...:media_id -rt robot_type -rn robot_number -rh
robot_control_host [-v volume_group]
```

Move (eject) multiple volumes from a TL8 or TLD robot to stand-alone

```
install_path\Volmgr\bin\vmchange -multi_eject -w [-h EMM_server |
volume_database_host] -res -ml media_id:media_id: ...:media_id -rt
robot_type -verbose -rn robot_number -rh robot_control_host
```

Move (inject) multiple volumes into a TL8 or TLD robot

```
install_path\Volmgr\bin\vmchange -multi_inject -w [-h EMM_server |
volume_database_host] -res -rt robot_type -verbose -rn robot_number
-rh robot_control_host
```

Get robot information for a TL8 or TLD robot type

```
install_path\Volmgr\bin\vmchange [-h EMM_server | volume_database_host]
-res -robot_info -verbose -rn robot_number -rt robot_type -rh
robot_control_host
```

DESCRIPTION

Change volume information in the Enterprise Media Manager database.

Any authorized user can run this command.

For more information about NetBackup authorization, refer to the *NetBackup Security and Encryption Guide*.

OPTIONS

-h *EMM_server* | *volume_database_host*

This option is only applicable for NetBackup Enterprise Server.

The name of the Enterprise Media Manager database host that contains information about volumes. If no host is specified, the configured EMM server is used by default. For communicating with pre-6.0 systems not in the EMM domain, this server is the EMM server.

-vg_res

Change volume group residence.

-rt *robot_type*

Specifies the robot type of the robot where the volume is located.

Valid robot types for NetBackup Enterprise Server follow:

none, acs, odl, tl4, tl8, tld, tlh, tlm, tsh

Valid robot types for NetBackup Server follow:

none, tl4, tl8, tld

-rn *robot_number*

Unique, logical identification number for the robot where the volume is located.

`-rh robot_control_host`

Name of the host that controls the robot, where the volume is located.

`-v volume_group`

A volume group is a logical grouping that identifies a set of volumes that reside at the same physical location.

`-res`

Change the volume's residence.

`-m media_id`

Specifies the media ID of the volume to change.

`-mt media_type`

Specifies the media type of the volume to change.

Valid media types for NetBackup Enterprise Server follow:

4mm, 8mm, 8mm2, 8mm3, dlt, dlt2, dlt3, dtf, hcart, hcart2, hcart3, odiskwm, odiskwo, qcart, 4mm_clean, 8mm_clean, 8mm2_clean, 8mm3_clean, dlt_clean, dlt2_clean, dlt3_clean, dtf_clean, hcart_clean, hcart2_clean, hcart3_clean

Valid media types for NetBackup Server follow:

4mm, 8mm, dlt, hcart, qcart, 4mm_clean, 8mm_clean, dlt_clean, hcart_clean

`-rc1 rob_slot`

Robot coordinate 1 is the slot number in the robot where the volume is located.

The following applies only to NetBackup Enterprise Server:

Do not enter slot information for API robot types. The robot software tracks the slot locations for these robots.

`-rc2 rob_side`

This option is only applicable for NetBackup Enterprise Server.

Robot coordinate 2 is the platter side for optical disks (A or B).

`-exp date`

Expiration date for this volume.

The format of *date* depends on the user's locale setting. See the NOTES section for more information. For the C locale, the date syntax is as follows:

mm/dd/yyyy [hh[:mm[:ss]]]

`-barcode barcode`

Specifies the barcode that is attached to the volume.

- `-d "media_description"`
Media description for the volume. The double quote marks are required if the description contains any spaces.
- `-p pool_number`
Index of the volume pool that contains this volume. You can get the pool index using `vmppool -listall`.
- `-maxmounts max_mounts`
Maximum number of mounts allowed for this volume. Only used for non-cleaning media.
- `-n num_mounts`
For non-cleaning media, *num_mounts* is the number of times this volume has been mounted.
- `-clean cleanings_left`
For cleaning media, *cleanings_left* is the number of cleanings that remain for this cleaning tape.
- `-new_mt media_type`
Specifies the media type of the volume to change. See the `-mt` option for a list of media types.
- `-new_rt robot_type`
Specifies the robot type. See the `-rt` option for a list of robot types.
- `-new_v volume_group`
A volume group is a logical grouping that identifies a set of volumes that reside at the same physical location.
- `-b barcode`
Specifies the barcode that is attached to the volume.
- `-vltcid vault_container_id`
Change the container in which a volume is stored. *vault_container_id* (a string of up to 29 alphanumeric characters) specifies the new container for the volume. Use the `-m` or `-barcode` option to specify the volume.
- `-vltname vault_name`
Specifies the name of the logical vault that is configured for the robot that ejected the volume.
- `-vltsent date`
Specifies the date the volume was sent off site.
The format of *date* depends on the user's locale setting. See the NOTES section for more information. For the C locale, the date syntax is as follows:
mm/dd/yyyy [hh[:mm[:ss]]]

`-vltreturn date`

Specifies the date the volume was requested for return from the vault vendor. For catalog backup volumes, this date is the date that the volume is requested for return from the vault vendor.

The format of *date* depends on the user's locale setting. See the NOTES section for more information. For the C locale, the date syntax is as follows:

mm/dd/yyyy [hh[:mm[:ss]]]

`-vltslot vault_slot`

Specifies the vault vendor's slot number for the slot that this volume occupies.

`-vltsession vault_session_id`

Specifies the ID of the vault session that ejected this media.

`-api_eject`

Eject ACS, TLH, or TLM volumes from the specified robot. For ACS and TLM robots, the ejection timeout period is one week. For TLH robots, the robot allows an unlimited period to remove media.

`-map map_id:mapid: ...:mapid | any`

For ACS robots, this option can specify multiple media access ports (MAPs) to use for eject operations. The *map_id* (also known as the CAP ID) can be `all` or `ALL`, which specifies all MAPs in the robot. Or it can be a colon-separated list of MAP IDs in the format of `ACS,LSM,CAP`. When the `-map` option is used, media are ejected to the MAPs that are specified by using a nearest MAP algorithm. The algorithm assumes that the LSMs are connected in a line. If your LSMs connect in a configuration other than a line, see the *NetBackup Administrator's Guide: Adjacent LSM Specification for ACS Robots and Media Access Port Default for ACS Robots*.

For TLM robots, use `map_id "ANY"` to eject to the MAP that is configured for each media type on the DAS/SDLC server.

For TLH robots, select the "standard" MAP or the "BULK" MAP, depending on the library's hardware configuration.

`-w`

Wait flag. This flag must be used with the `eject`, `multiple eject`, and `multiple inject` commands.

`-verbose`

Selects the verbose mode.

`-ml media_id:media_id: ...:media_id`

Specifies a list of media to be ejected from the robot.

-multi_eject

Uses the robotic library's media access port to eject multiple volumes. This option is valid only for TL8 and TLD robot types. The ejection timeout period is 30 minutes.

-multi_inject

Uses the robotic library's media access port to inject multiple volumes. This option is valid only for TL8 and TLD robot types. The user must run the `vmupdate` command after this operation to update the EMM database.

-robot_info

Retrieves information about a robotic library. This option is valid only for TLD and TL8 robot types

CAUTIONS

Some robotic libraries implement different functionality for their media access ports. For example, some libraries have the front-panel inject and the eject features that conflict with NetBackup's use of the media access port. (For example, Spectra Logic Bullfrog.) Other libraries require front-panel interaction when you use the media access port (for example, Spectra Logic Gator).

The media is returned to (injected into) the robot in the following situation: you use an eject option and the media is not removed and a time-out condition occurs. If this action occurs, inventory the robot and then eject the media that was returned to the robot.

Make sure you read the operator manual for your robotic library to gain an understanding of its media access port functionality. Libraries such as the ones noted may not be fully compatible with NetBackup's inject and eject features if not properly handled. Other libraries may not be compatible at all. In addition, NetBackup performs limited validation of these option parameters.

EXAMPLES

Example 1

The following command changes the expiration date of volume AJS100:

```
vmchange -exp 12/31/99 23:59:59 -m AJS100
```

Example 2

The following command changes the pool (which contains volume AJS999) to pool 1 (the NetBackup pool):

```
vmchange -p 1 -m AJS999
```

Example 3

The following command ejects volumes `abc123` and `abc124` from ACS robot number 700. The residences for these two volumes are changed to stand-alone.

```
vmchange -res -api_eject -w -ml abc123:abc124 -rt acs -rn  
700 -rh verbena -map 0,0,0
```

Example 4

The following command changes the container ID of volume `ABC123`:

```
vmchange -vltcid Container001 -m ABC123
```

NOTES

The format that you use for date and time option values varies according to your locale setting. The examples in this command description are for a locale setting of C.

SEE ALSO

`vmadd`, `vmdelete`, `vm pool`, `vmquery`

vmcheckxxx

NAME

vmcheckxxx - report the media contents of a robotic library

SYNOPSIS

```
install_path\Volmgr\bin\vmcheckxxx -rt robot_type -rn robot_number [-rh  
robot_host] [-h EMM_server | volume_database_host] [[-if  
inventory_filter_value] [-if inventory_filter_value] ...] [-full]  
[-list]
```

DESCRIPTION

Report the media contents of a robotic library and optionally compare its contents with the volume configuration.

If no options are specified, the media contents of the robot and the volume configuration are listed along with a list of any mismatches detected.

Any authorized user can run this command.

For more information about NetBackup authorization, refer to the *NetBackup Security and Encryption Guide*.

OPTIONS

-rt *robot_type*

Specifies the robot type of the robot to inventory.

Valid robot types for NetBackup Enterprise Server follow:

none, acs, odl, tl4, tl8, tld, tlh, tlm, tsh.

Valid robot types for NetBackup Server follow:

none, tl4, tl8, tld.

-rn *robot_number*

Unique, logical identification number of the robot to inventory.

-rh *robot_host*

Name of the host that controls the robot. If no host is specified, the host where you execute this command is assumed.

-h *EMM_server* | *volume_database_host*

This option is only applicable for NetBackup Enterprise Server.

The name of the Enterprise Media Manager database host that contains information about the volumes in a robot. If no host is specified, the

configured EMM server is used by default. For communicating with pre-NetBackup 6.0 systems not in the EMM domain, this server is the EMM server.

`-if inventory_filter_value`

This option is only applicable for NetBackup Enterprise Server.

Specifies the inventory filter values. Multiple `-if` options may be specified. The inventory filter value is an ACS scratch pool ID, or a TLH volume category.

The `-if` and `-full` options cannot be specified together.

`-full`

Specifies the full inventory. The `-full` and `-if` options cannot be specified together.

`-list`

Lists the robot contents.

NOTES

Only limited validation of the option parameters is done.

EXAMPLES

The following command lists the media contents of TLD robot 1 and the volume configuration for that robot on the host named server2. It also lists any mismatches that are detected:

```
vmcheckxxx -rt tld -rn 1 -rh server2
```

The following command lists the contents of TLH robot 2 that is connected to the host where the `vmcheckxxx` command was ran:

```
vmcheckxxx -rt tlh -rn 2 -list
```

SEE ALSO

`vmupdate`

vmdelete

NAME

vmdelete - delete volumes from EMM database

SYNOPSIS

```
install_path\Volmgr\bin\vmdelete [-h EMM_server | volume_database_host]  
[-m media_id | -v volume_group]
```

DESCRIPTION

Delete volumes from the Enterprise Media Manager database.

Any authorized user can run this command.

For more information about NetBackup authorization, refer to the *NetBackup Security and Encryption Guide*.

OPTIONS

-h *EMM_server* | *volume_database_host*

This option is only applicable for NetBackup Enterprise Server.

The name of the Enterprise Media Manager database host that contains information about volumes. If no host is specified, the configured EMM server is used by default. For communicating with pre-NetBackup 6.0 systems not in the EMM domain, this server is the EMM server.

-m *media_id*

Specifies the media id of the volume to delete from the volume database.

-v *volume_group*

Specifies the volume group to delete. All volumes in this group are deleted from the volume database.

NOTES

Only limited validation of the option parameters is done.

EXAMPLES

The following command deletes a single volume:

```
vmdelete -m AJS144
```

The following command deletes all volumes with the volume group name of DELETE_ME:

```
vmdelete -v DELETE_ME
```

SEE ALSO

vmadd, vmchange, vmquery

vmopr cmd

NAME

vmopr cmd - perform operator functions on drives

SYNOPSIS

Device Host commands

```
install_path\Volmgr\bin\vmopr cmd -devmon [pr | ds | hs] default operation
```

```
install_path\Volmgr\bin\vmopr cmd -dp [pr | ds | ad] [-h device_host]
```

Up/Down/Reset drive commands

```
install_path\Volmgr\bin\vmopr cmd -down | -up | -upopr | -reset drive_index  
[-h device_host]
```

```
install_path\Volmgr\bin\vmopr cmd -downbyname | -upbyname | -upoprbyname |  
-path drive_path] [-nh ndmp_hostname] [-h device_host]
```

```
install_path\Volmgr\bin\vmopr cmd -resetbyname drive_name [-h device_host]
```

Assign mount request to drive commands

```
install_path\Volmgr\bin\vmopr cmd -assign drive_index mount_request_id [-h  
device_host]
```

```
install_path\Volmgr\bin\vmopr cmd -assignbyname drive_name  
mount_request_id [-h device_host]
```

Deny or resubmit mount request command

```
install_path\Volmgr\bin\vmopr cmd -deny | -resubmit mount_request_index  
[-h device_host]
```

Comment the drive command

```
install_path\Volmgr\bin\vmopr cmd -comment drive_index ["comment"] [-h  
device_host]
```

```
install_path\Volmgr\bin\vmopr cmd -commentbyname drive_name ["comment"]  
[-h device_host]
```

SCSI release of SSO drive command

```
install_path\Volmgr\bin\vmopr cmd -crawlreleasebyname drive_name [-h  
EMM_Server]
```

Activate/Deactivate host command

```
install_path\Volmgr\bin\vmopr cmd [-activate_host | -deactivate_host] [-h  
device_host]
```

Get host status command

```
install_path\Volmgr\bin\vmopr cmd -hoststatus [-h device_host]  
Display usage command
```

```
install_path\Volmgr\bin\vmopr cmd -help
```

The following usage is provided for backward compatibility only:

```
install_path\Volmgr\bin\vmopr cmd [-h volume_database_host] {-d [pr | ds |  
ad] | -dps [drive_name]}
```

DESCRIPTION

Perform operator functions on drives. The `-h` option is not required, but you must choose only one of the following other options.

Non NDMP Windows device paths appear as {p,b,t,l}: where p is the port, b is the bus, t is the target, and l is the lun. When `vmopr cmd` is run by using the `-path` argument, specify the path in the {p,b,t,l} format.

Any authorized user can run this command.

For more information about NetBackup authorization, refer to the *NetBackup Security and Encryption Guide*.

OPTIONS

```
-assign drive_index mount_request_id
```

Assign a drive to a mount request.

```
-assignbyname drive_name mount_request_id
```

This option is similar to the `-assign` option, except the drive name specifies the drive instead of the drive index.

The following point applies only to NetBackup Server:

The device host is the host where Media Manager is installed.

```
-comment drive_index ["comment"]
```

Add a comment for the drive. The quotes are required if your comment contains any spaces. If you do not specify *comment*, any existing comments for the drive are deleted.

```
-commentbyname drive_name ["comment"]
```

This option is similar to the `-comment` option, except the drive name specified the drive instead of drive index.

```
-crawlreleasebyname drive_name
```

This option is only applicable for NetBackup Enterprise Server.

This option forces all hosts (that are registered to use the drive) to issue a SCSI release command to the drive. Issue this option on the host that is the SSO device allocator (DA host) or use the `-h` option to specify the DA host.

Caution: Use this option after a PEND status has been seen in **Device Monitor**. Do not use this option during backups.

`-down` | `-up` | `-upopr` | `-reset` *drive_index*

- `-down` Sets the drive to the DOWN state, if it is not assigned.
- `-up` Sets the drive to the UP position in Automatic Volume Recognition (AVR) mode. This mode is the normal mode for all drives.
- `-upopr` Sets the drive to the UP position in Operator (OPR) mode. This mode is normally used only for security reasons. For a drive in a robot, OPR and AVR are treated identically while the robot daemon or process is running.
- `-reset` Resets the specified drive. It terminates the drive assignment and takes control away from the assigned user.

Caution: Do not reset an assigned drive unless directed by site policy or the system administrator. If you terminate an active job, it can destroy user data.

`-downbyname` | `-upbyname` | `-upoprbyname` | `-resetbyname` *drive_name*

These options are similar to `-down`, `-up`, `-upopr`, and `-reset` respectively, except the drive name specifies the drive instead of the drive index.

`-deny` | `-resubmit` *mount_request_id*

- `-deny` Denying a mount request returns an error message to the user.
- `-resubmit` Resubmit a mount request. If a pending action message involves a robot, you must correct the problem and resubmit the request that caused the message.

`-d` [`pr` | `ds` | `ad`]

This command is supported for pre-NetBackup 6.0 systems. If none of the following optional display parameters are specified, all information is displayed.

- `pr` Displays any pending requests.
- `ds` Displays the status of drives under control of Media Manager.
- `ad` Displays additional status of drives under control of Media Manager.

`-devmon` | `-dp` [`pr` | `ds` | `hs`]

The `-dp` command lists all of the drive paths that are configured for a given drive name. If none of the following optional display parameters are specified, all information is displayed.

- `pr` Displays any pending requests.

- `ds` Displays the status of drives under control of Media Manager.
- `hs` Displays additional status of drives under control of Media Manager.
- `-dps [drive_name]`
Lists all of the drive paths that are configured for a given drive name..
- `-h EMM_Server | volume_database_host | device host`
Name of the Enterprise Media Manager database host where the drives are attached and configured. (For communicating with pre-6.0 systems not in the EMM domain, this server is the EMM server.) If no host option is specified, the device host where you run the command is default.
The *device host* is the host where the device is attached and configured.
The *volume_database_host* is the host where the device is attached and configured for pre-6.0 systems.
- `-help`
Displays the usage statement for this command.
- `-hoststatus`
Displays the current status of the host. The following states can appear:
DEACTIVATED - This state prevents any new jobs from starting on this host.
ACTIVE - The media server is available to run any jobs.
ACTIVE-DISK - The media server is available to run jobs for disk storage units only.
ACTIVE-TAPE - The media server is available to run jobs for tape storage units only.
OFFLINE - The media server is not available to run jobs for either tape storage units or disk storage units. This state occurs because the media server is not active for tape or disk, or because the master server cannot communicate with the media server.
- `-nh ndmp_hostname`
Specifies the hostname of the NDMP server.
- `-activate_host`
Makes the host available to run jobs.
- `-deactivate_host`
Makes the host unavailable to run jobs.
- `-path drivepath`
Specifies the system name for the drive. For example, /dev/rmt/0cbn.
- `-setpath drivepath drive_name ndmp_hostname`
Specifies the system name and the drive name of the NDMP host.

NOTES

Only limited validation of the option parameters is done.

tpconfig -d, tpconfig -l, and vmopr cmd may truncate long drive names. Please use tpconfig -dl to obtain the full drive name.

vmopr cmd may truncate drive names to 20 characters.

EXAMPLES

Example 1

The following command sets the drive, with a drive index of 0, to UP mode:

```
vmopr cmd -up 0
```

Example 2

The following command displays the drive status of all drives:

```
vmopr cmd -d ds
```

Example 3

The following command displays pending requests and the drive status of all drives on the device host named crab:

```
vmopr cmd -h crab
```

Example 4

The following command demonstrates how non-NDMP Windows device paths appear.

```
<install_path>\Volmgr\bin>vmopr cmd
```

```

                                HOST STATUS
Host Name                        Version  Host Status
=====  =====  =====
hamex                                600000  ACTIVE

                                PENDING REQUESTS
                                <NONE>
                                DRIVE STATUS

Drive Name      Label  Ready  RecMID  ExtMID  Wr.Enbl.  Type
Host            DrivePath                               Status
=====
==
IBM.ULTRIUM-TD2.001  No    No                No    hcart2
  hamex            {3,1,0,2}                TLD
  hamex            {3,1,1,2}                TLD

```

IBM.ULTRIUM-TD2.002	No	No	No	hcart2
hamex		{3,1,0,5}		TLD
hamex		{3,1,1,5}		TLD
IBM.ULTRIUM-TD1.003	No	No	No	hcart
hamex		{3,1,0,6}		TLD
hamex		{3,1,1,6}		TLD
IBM.ULTRIUM-TD1.004	No	No	No	hcart
hamex		{3,1,0,7}		TLD
hamex		{3,1,1,7}		TLD
IBM.ULTRIUM-TD2.005	Yes	Yes	J945L2	hcart2
hamex		{3,1,2,1}		TLD
IBM.ULTRIUM-TD2.006	No	No	No	hcart2
hamex		{3,1,2,2}		TLD

C:\Program Files\VERITAS\Volmgr\bin>

C:\Program Files\VERITAS\Volmgr\bin>vmopr cmd
 -downbyname IBM.ULTRIUM-TD1.003 -path {3,1,0,6}

SEE ALSO

tpconfig

vmphyinv

NAME

vmphyinv - inventory media contents of a robotic library or stand-alone drive and update the volume database

SYNOPSIS

```

install_path\volmgr\bin\vmphyinv -rn robot_number] [-rh
  robot_control_host] [-h device_host]
[-pn pool_name] [-v volume_group] [-rc1 robot_coord1 -number number]
[-drv_cnt count] [-non_interactive] [-mount_timeout timeout] [-verbose]
install_path\volmgr\bin\vmphyinv -rn robot_number] [-rh
  robot_control_host] [-h device_host]
-ml media_id:media_id:...:media_id [-drv_cnt count]
[-non_interactive] [-mount_timeout timeout] [-verbose]
install_path\volmgr\bin\vmphyinv -rn robot_number] [-rh
  robot_control_host] [-h device_host]
[
{ { [-slot_range from to] [-slot_list s1:s2:...:sN] } -d density }
{ { [-slot_range from to] [-slot_list s1:s2:...:sN] } -d density }
]
[-drv_cnt count] [-non_interactive] [-mount_timeout timeout] [-verbose]

install_path\volmgr\bin\vmphyinv {-u drive_number | -n drive_name} [-h
  device_host]
[-non_interactive] [-mount_timeout timeout] [-verbose]

```

DESCRIPTION

Physically inventory the media contents of a robotic library or stand-alone drive and update the EMM database. Based on information in the tape header, **vmphyinv** mounts each media that the search criterion specifies, reads the tape header, and updates the EMM database.

For more information about this command, refer to the *NetBackup Administrator's Guide, Volume I*.

Any authorized user can run this command.

For more information about NetBackup authorization, refer to the *NetBackup Encryption Guide*.

OPTIONS

- `-rn robot_number`
Specifies the Media Manager robot number whose media is inventoried. `robot_number` should correspond to a robot with already configured drives. `vmphyinv` inventories each of the media, having `robot_number` in the volume database of `robot_number`.
- `-rh robot_host`
Specified the name of the host that controls the robot. If no host is specified, the host where this command is executed is assumed.
- `-h device_host`
Specifies the device host name. This option is used to obtain the Enterprise Media Manager Server name. If not specified, the current host is used to obtain the EMM server name.
- `-pn pool_name`
Specifies the case-sensitive pool name of the volumes, which corresponds to the robot that the `-rn` option specifies, which need to be inventoried. Valid only when the `-rn` option is specified.
- `-v volume_group`
Specifies the volume group of the volumes, that correspond to the robot that the `-rn` option specifies, which need to be inventoried. Valid only when the `-rn` option is specified.
- `-rc1 robot_coord1`
Specifies the starting slot of the media that needs to be inventoried. Valid only when the `-rn` option is specified.
- `-number number`
Specifies the number of slots that start from `robot_coord1` that need to be inventoried. Valid only when `-rn` and `-rc1` are also specified.
- `-ml media_id1:media_id2: ... :media_idN`
Specifies a list of media, which need to be inventoried. Valid only when `-rn` option is specified. If the media ID that is specified does not belong to the specified robot, the media is skipped.
- `-slot_range from to`
Specifies a range of slots that need to be inventoried. If one or more slots are empty, those slots are skipped.

- `-slot_list s1:s2:...sN`
Specifies a list of slots that need to be inventoried. If one or more slots are empty, those slots are skipped.
- `-d density`
Specifies the density of the media. The user must specify the media density while inventorying the media by slot range/list.
- `-u drive_number`
Specifies the drive index that needs to be inventoried. The drive must contain media and be ready. The number for the drive can be obtained from the Media Manager device configuration.
- `-n drive_name`
Specifies the drive name that needs to be inventoried. The drive must contain media and be ready. The name for the drive can be obtained from the Media Manager device configuration.
- `-non_interactive`
vmphyinv, in the default mode displays a list of recommendation and ask for confirmation before modifying volume database and Enterprise Media Manager Database (if required). If this option is specified, the changes are applied without any confirmation.
- `-mount_timeout timeout`
Specifies the mount timeout in seconds. If the media cannot be mounted within the specified time, the mount request is cancelled. The default value is 15 minutes.
- `-drv_cnt count`
Specifies the maximum number of drives that can be used simultaneously by vmphyinv. The total number of configured drives and this value determine the actual number of drives vmphyinv uses. The number of drives that vmphyinv uses is the minimum of the specified drive count and the total number of configured drives. The default is to use all the drives.
- `-verbose`
Selects the verbose mode. When you specify this option, more information appears. (For example: the number of available drives, what is found on each tape, and catalog identification if the media is a catalog.)

EXAMPLES

The following command updates the EMM database of robot 1 connected to host shark:

```
vmphyinv -rn 1 -rh shark
```

The following command updates the EMM database of robot 7 connected to host whale. Only the media that belongs to the pool name "some_pool" is inventoried:

```
vmphyinv -rn 7 -rh whale -pn some_pool
```

The following command updates the EMM database of robot 3 connected to host dolphin. Only the media A00001, A00002, A00003 is inventoried.

```
vmphyinv -rn 3 -rh dolphin -ml A00001:A00002:A00003
```

The following command updates the EMM database of robot 2 of type TLD that is connected to host phantom. It only inventories the media in slots 3 to 8.

```
vmphyinv -rn 2 -rh phantom -slot_range 3 8 -d dlt
```

The following command updates the EMM database of stand-alone drive (drive index 3) attached to host tigerfish:

```
vmphyinv -u 0 -h tigerfish
```

SEE ALSO

vmupdate, vmcheckxxx, vmoprcmd

vmpool

NAME

vmpool - manage volume pools

SYNOPSIS

```
install_path\Volmgr\bin\vmpool [-h EMM_server | volume_database_host]
-list_all [-b|-bx] | -list_scratch | -list_catalog_backup | -create
-pn pool_name -description description [-mpf mpf_max] | -update -pn
pool_name [-description description] [-mpf mpf_max] | -delete
pool_name | -set_scratch pool_name | -unset_scratch pool_name |
-set_catalog_backup pool_name | -unset_catalog_backup pool_name
```

DESCRIPTION

Use this command to add, change, delete, or list volume pools.

The `-h` option is not required, but you must choose one and only one of the other seven options (for example, `-list_scratch`).

Any authorized user can run this command.

For more information about NetBackup authorization, refer to the *NetBackup Security and Encryption Guide*.

OPTIONS

`-h EMM_server | volume_database_host`

This option applies only to the NetBackup Enterprise Server.

Specifies the name of the Enterprise Media Manager database host that contains information about volumes. If no host is specified, the configured EMM server is used by default. For communicating with pre-6.0 systems not in the EMM domain, this server is the volume database host.

`-list_all [-b | -bx]`

Lists the information about all volume pools. Use the `-b` or `-bx` option to specify a brief format for volume pool information.

`-list_scratch`

Lists all configured scratch pools and the pool index number.

`-list_catalog_backup`

Lists the volume pool to be used for catalog backup.

`-create -pn pool_name -description description -mpf mpf_max`

Adds a new volume pool. Optionally limits the number of partially full media to be used in this pool by using `-mpf`. The default value is zero (0), which indicates that the number of partially full media is unlimited.

The `-description` option describes the volume pool. Double quote marks are required if the description contains any spaces.

`-update -pn pool_name [-description description] [-mpf mpf_max]`

Changes an existing volume pool. Optionally limits the number of partially full media to be used in this pool by using `-mpf`. The default value is zero (0), which indicates that the number of partially full media is unlimited.

The `-description` option describes the volume pool. Double quote marks are required if the description contains any spaces.

`-delete pool_name`

Deletes a volume pool.

`-set_scratch pool_name`

If *pool_name* is a previously defined volume pool, *pool_name* becomes the scratch pool and its description is not changed. The NetBackup, DataStore, Catalog Backup, and None volume pools cannot be changed to scratch pools.

If *pool_name* is a new volume pool, a new pool is created with "Scratch Pool" as the description.

Only one scratch pool at a time can be defined.

`-unset_scratch pool_name`

Undefines *pool_name* as the scratch pool and defines it as a regular volume pool. The pool can be deleted by using `vmpool -delete pool_name`.

`-set_catalog_backup_pool pool_name`

Specifies the volume pool to back up the NetBackup catalog. You can also create a dedicated catalog backup pool to be used for catalog policies. A dedicated catalog volume pool reduces the number of needed tapes during catalog restores since catalog backup media are not mixed with other backup media.

`-unset_catalog_backup_pool pool_name`

Defines a volume pool that you do not want to use to back up the NetBackup catalog.

NOTES

Only limited validation of the option parameters is done.

A pool cannot be both a scratch pool and Catalog Backup pool.

The `-add` and `-change` options have been deprecated. They can still be used, but do not set the `mpf` value.

EXAMPLES

The following command adds a new pool named `MyPool` on the host that is named `llama`. It has the default host, user ID, and group ID permissions:

```
vmpool -create -pn MyPool -description "description with spaces" -mpf 17
```

The following command lists all pools that are configured on the host where the command is executed:

```
vmpool -list_all -b
```

vmquery

NAME

vmquery - query EMM database, or assign and unassign volumes

SYNOPSIS

```
install_path\Volmgr\bin\vmquery [-h EMM_server, ... -h EMM_server |  
volume_database_host, ... -h volume_database_host] [-vltcid  
vault_container_id] [-W] [-b | -w] -a | -m media_id | -v volume_group |  
-rn robot_number | -rt robot_type | -mt media_type | -p pool_number |  
-pn pool_name | -res robot_type robot_number robot_host rob_slot  
rob_side | -assignbyid media_id media_type pool_number stat asg_time |  
-deassignbyid media_id pool_number stat
```

DESCRIPTION

Query the EMM database for volume information. The `-h`, `-b`, and `-w` options are not required, but you must choose only one of the other (eleven) options.

The `-b` or `-w` option can be used with any of the other eleven options, but the `-b` or `-w` options cannot be specified together.

Any authorized user can run this command.

For more information about NetBackup authorization, refer to the *NetBackup Security and Encryption Guide*.

OPTIONS

`-h EMM_Server | volume_database_host`

This option is only applicable for NetBackup Enterprise Server.

The name of the Enterprise Media Manager database host that contains information about volumes. If no host is specified, the configured EMM server is used by default. For communicating with pre-NetBackup 6.0 systems not in the EMM domain, this server is the volume database host.

`-b`

Specifies the brief output format for volume information. This option can be used with any of the other eleven options.

`-w`

Specifies the wide output format for volume information. This option includes any additional information that the `-b` option does not show and can be used with any of the other eleven options.

- a
Shows all volumes.
- m *media_id*
Queries the volumes by media id. The media id is a maximum of 6 ASCII characters.
- v *volume_group*
Queries the volumes by volume group. A volume group is a logical grouping that identifies a set of volumes that reside at the same physical location.
- rn *robot_number*
Queries the volumes by robot number. A robot number is a unique, logical identification number for the robot where the volume is located.
- rt *robot_type*
Queries the volumes by the type of robot where the volume is located. *Valid robot types for NetBackup Enterprise Server follow:*
none, acs, odl, tl4, tl8, tld, tlh, tlm, tsh.
Valid robot types for NetBackup Server follow:
none, tl4, tl8, tld.
- mt *media_type*
Queries the volumes by media type.
Valid media types for NetBackup Enterprise Server follow:
4mm, 8mm, 8mm2, 8mm3, dlt, dlt2, dlt3, dtf, hcart, hcart2, hcart3, odiskwm, odiskwo, qcart, 4mm_clean, 8mm_clean, 8mm2_clean, 8mm3_clean, dlt_clean, dlt2_clean, dlt3_clean, dtf_clean, hcart_clean, hcart2_clean, hcart3_clean.
Valid media types for NetBackup Server follow:
4mm, 8mm, dlt, hcart, qcart, 4mm_clean, 8mm_clean, dlt_clean, hcart_clean.
- p *pool_number*
Queries the volumes by pool number. Pool number is an index into the volume pool. You can use `vmppool -listall` to determine the index for a given pool name.
- pn *pool_name*
Queries the volumes by pool name.
- res *robot_type robot_number robot_host rob_slot rob_side*
Queries the volumes by residence.
- robot_host*
Specifies the host that controls the robot where the volume is located.

rob_slot

Specifies the slot number in the robot (robot coordinate 1) where the volume resides.

rob_side

Specifies the platter side (robot coordinate 2) for optical disks (A or B). If the volume is not an optical disk, specify zero for this option.

`-assignbyid media_id media_type pool_number stat asg_time`

Assigns the volume by media ID, pool, and status.

stat

Status applies only to volumes that are assigned to NetBackup or Storage Migrator. Possible *stat* values are:

0 - the volume is assigned to NetBackup regular backups.

1 - Volume is assigned to NetBackup catalog backups.

2 - Volume is assigned to Storage Migrator.

3 - Volume is assigned to Storage Migrator for Microsoft Exchange or Storage Migrator for Windows 2000.

asg_time

Note: This option applies only to volumes that are assigned to NetBackup or Storage Migrator.

Specifies the time when the volume was assigned. It is the number of seconds since 00:00:00 UTC, January 1, 1970. *asg_time* was originally created by using the `time()` call.

`-deassignbyid media_id pool_number stat`

Unassigns the volume by media ID, pool, and status. This option can only deassign non-NetBackup media. Non-NetBackup media includes the media that the following use: Veritas Storage Migrator, Veritas Data Lifecycle Manager, or by users that work outside of the NetBackup policy framework (for example, those using `tpreq` directly). To deassign NetBackup tapes, use the `bpexpdate` command.

`-vltcid vault_container_id`

Lists the volumes that are stored in the container. The *vault_container_id* variable can be a string of up to 29 alphanumeric characters.

`-w`

Specifies the parsable output format for volume information. The output data lines are space separated fields except:

- The MediaID field is padded to 6 characters by adding spaces to the end of the string.

- The MediaType field is padded to 8 characters by adding spaces to the end of the string.
- The MediaDescription field may contain spaces within the field.
For Vault containers, the output includes the length of the container description (DescriptionLength), the container description, and the container ID. The output header line is a space-separated line of column labels.

NOTES

Only limited validation of the option parameters is done.

EXAMPLES

The following command lists all volume information, in brief format from the Enterprise Media Manager database on the host that is named llama:

```
vmquery -h llama -b -a
```

The following command assigns volume A23456, which is in pool 1 (NetBackup). It sets the status to 0 and the assign time to 12/31/98 15:50:22:

```
vmquery -assignbyid A23456 8mm 1 0 915141022
```

The following command unassigns volume A23456, which is in pool 2 (Storage Migrator), with a status of 0:

```
vmquery -deassignbyid A23456 0
```

SEE ALSO

vmadd, vmchange, vmdelete, vmpool

vmrule

NAME

vmrule - manage barcode rules

SYNOPSIS

```
install_path\Volmgr\bin\vmrule [-h EMM_server | volume_database_host]
  -listall [-b] | -add barcode_tag media_type pool_name max_mounts
  "description" | -change barcode_tag media_type pool_name max_mounts
  "description" | -delete barcode_tag
```

DESCRIPTION

Use `vmrule` to add, change, delete, or list barcode rules. The `-h` option is not required, but you must choose one and only one of the other four options.

Any authorized user can run this command.

For more information about NetBackup authorization, refer to the *NetBackup Security and Encryption Guide*.

OPTIONS

`-h EMM_server | volume_database_host`

This option is only applicable for NetBackup Enterprise Server.

The name of the Enterprise Media Manager database host that contains information about the volumes in a robot. If no host is specified, the configured EMM server is used by default. This server is the EMM server for communicating with pre-NetBackup 6.0 systems not in the EMM domain.

`-listall [-b]`

List information about all barcode rules. You can use the `-b` option to specify a brief format for the barcode rule information that is displayed.

`-add barcode_tag media_type pool_name max_mounts "description"`

Add a new barcode rule.

`-change barcode_tag media_type pool_name max_mounts "description"`

Change a barcode rule.

`-delete barcode_tag`

Delete a barcode rule.

`barcode_tag`

Specifies the barcode prefix that activates the barcode rule.

media_type

Specifies the media type of the volume, a barcode rule attribute. This option affects whether the rule is used and also affects the media type for the volumes that are added by using a robot inventory update.

Valid media types for NetBackup Enterprise Server follow:

4mm, 8mm, 8mm2, 8mm3, dlt, dlt2, dlt3, dtf, hcart, hcart2, hcart3, odiskwm, odiskwo, qcart, 4mm_clean, 8mm_clean, 8mm2_clean, 8mm3_clean, dlt_clean, dlt2_clean, dlt3_clean, dtf_clean, hcart_clean, hcart2_clean, hcart3_clean.

Valid media types for NetBackup Server follow:

4mm, 8mm, dlt, hcart, qcart, 4mm_clean, 8mm_clean, dlt_clean, hcart_clean.

pool_name

Specifies the pool to which the volumes are added.

max_mounts

Maximum number of mounts allowed for this volume (when the volume is added). This option is used only for non-cleaning media. When this limit is exceeded, the volume can only be mounted for read operations.

Note: Numbers larger than 99999 are stored in the database, but `vmrule` displays the *max_mounts* as 0 if the value is larger than 99999. A value of 0 means that the number of mounts is unlimited.

"description"

Description of the barcode rule. The double quote marks are required if the description contains any spaces.

NOTES

Only limited validation of the option parameters is done.

EXAMPLES

The following command creates a rule that defines any tape with a barcode that starts with ABC is a DLT tape in the NetBackup pool. The tape can be mounted up to 100 times for writes and is given a description.

```
vmrule -add ABC dlt NetBackup 100 "DLT cleaning tape"
```

SEE ALSO

`vmupdate`

vmupdate

NAME

vmupdate - inventory media contents of a robotic library and update the EMM database

SYNOPSIS

```
install_path\Volmgr\bin\vmupdate -rt robot_type -rn robot_number [-rh robot_host] [-h EMM_Server | volume_database_host] [[-if inventory_filter_value] [-if inventory_filter_value] ...] [-full] [-recommend] [-interactive] [-involgrp volume_group] [-outvolgrp volume_group] [-mt media_type] [-p pool_name] [-use_barcode_rules] [-use_seed] [-mp media_id_prefix] [-no_sides] [-no_format_optical] [-overwrite_labels] [-empty_map]
```

DESCRIPTION

Inventory the media contents of a robotic library and update the Enterprise Media Manager database. If no options are specified, the volume configuration is updated to match the robot contents.

Any authorized user can run this command.

For more information about NetBackup authorization, refer to the *NetBackup Security and Encryption Guide*.

OPTIONS

-rt *robot_type*

Specifies the robot type of the robot to inventory.

Valid robot types for NetBackup Enterprise Server follow:

none, acs, odl, tl4, tl8, tld, tlh, tlm, tsh.

Valid robot types for NetBackup Server follow:

none, tl4, tl8, tld.

-rn *robot_number*

Unique, logical identification number for the robot to inventory.

-rh *robot_host*

Name of the host that controls the robot. If no host is specified, the host where you execute this command is assumed.

-h *EMM_server* | *volume_database_host*

This option is only applicable for NetBackup Enterprise Server.

The name of the Enterprise Media Manager database host that contains information about the volumes in a robot. If no host is specified, the configured EMM server is used by default. For communicating with pre-NetBackup 6.0 systems not in the EMM domain, this server is the EMM server. If no host is specified, but `-rh` specifies a pre-NetBackup 6.0 robotic control host, the robotic control host is used as the EMM server.

`-if inventory_filter_value`

This option is only applicable for NetBackup Enterprise Server.

Specifies the inventory filter values. Multiple `-if` options may be specified. The inventory filter value is an ACS scratch pool ID, or a TLH volume category.

The `-if` and `-full` options cannot be specified together.

`-full`

Specifies full the inventory. The `-full` and `-if` options cannot be specified together.

`-recommend`

Lists the changes that are required to update the volume configuration.

`-interactive`

Prompts you before it updates the volume configuration.

`-involgrp volume_group`

Specifies the volume group for the media that is moved into the robot.

`-outvolgrp volume_group`

Specifies the volume group for the media that is moved out of the robot.

`-mt media_type`

Specifies the media type of the volume.

Valid media types for NetBackup Enterprise Server follow:

4mm, 8mm, 8mm2, 8mm3, dlt, dlt2, dlt3, dtf, hcart, hcart2, hcart3, odiskwm, odiskwo, qcart, 4mm_clean, 8mm_clean, 8mm2_clean, 8mm3_clean, dlt_clean, dlt2_clean, dlt3_clean, dtf_clean, hcart_clean, hcart2_clean, hcart3_clean.

Valid media types for NetBackup Server follow:

4mm, 8mm, dlt, hcart, qcart, 4mm_clean, 8mm_clean, dlt_clean, hcart_clean.

`-p pool_name`

Specifies the name of the volume pool to which new media is assigned.

`-use_barcode_rules`

Specifies that barcode rules are used for assigning attributes to new media.

`-use_seed`

Specifies the automatic generation of media IDs for media with no barcodes.

`-mp media_id_prefix`

Specifies the prefix that is used as a seed to generate new media IDs for media with no barcodes. This prefix should be between 1 and 5 characters in length and contain only valid media ID characters (alpha-num, "+", "_", ".", and "-" if it is not the first character).

`-no_sides`

Specifies that any new optical media IDs do not always contain platter side A or B.

`-no_format_optical`

Specifies to NOT format new optical media.

`-overwrite_labels`

Specifies that existing labels are overwritten when you format optical media.

`-empty_map`

Specifies that volumes in the media access port (map) is moved into the robot before the robot inventory is started. This option is only valid for TL8, TLD, or TLM robot types.

NOTES

Only limited validation of the option parameters is done.

EXAMPLES

The following updates the volume configuration on the EMM server named *mymaster* to match the contents of TLD robot 7 connected to the host *macris*:

```
vmupdate -rt tld -rn 7 -rh macris -h mymaster
```

SEE ALSO

`vmcheckxxx`

vxlogcfg

NAME

vxlogcfg - modify unified logging configuration settings

SYNOPSIS

```
install_path\NetBackup\bin\vxlogcfg -a -p ProductID -c ConfigPath -n Names  
[-q]  
install_path\NetBackup\bin\vxlogcfg -a -p ProductID [-o OriginatorID ] -s  
keyname=value [-q]  
install_path\NetBackup\bin\vxlogcfg -d -p ProductID  
install_path\NetBackup\bin\vxlogcfg -r -p ProductID -o OriginatorID [-s  
keyname ] [-q]  
install_path\NetBackup\bin\vxlogcfg -l [-p ProductID ] [-o OriginatorID ]  
[-q]  
install_path\NetBackup\bin\vxlogcfg -v  
install_path\NetBackup\bin\vxlogcfg -h
```

DESCRIPTION

Use the `vxlogcfg` command to change the logging settings for a product that uses unified logging, such as NetBackup. It registers and unregisters the product log configurations during installation and uninstallation.

Unified logging uses a standardized naming format for log files, as follows:

```
productID-originatorID-hostID-date-rotation.log
```

For more information about the unified logging naming format, and the logging originator IDs, refer to the *NetBackup Troubleshooting Guide for UNIX, Windows, and Linux*.

OPTIONS

Specify the product log configuration to register or unregister. Use fully-qualified path names for all directory paths. If a directory name contains spaces, use quotes around the path name for that directory (for example, "Program Files").

`-a, --add`

Registers or creates the product log configuration settings. Any existing log settings are overwritten. Do not use this option to add a product to the list

of those that use unified logging. Instead, use it only to modify existing unified logging settings. See examples.

`-c, --config ConfigPath`

Provides the path from which the product log configuration settings should be read.

Use the path to the product log registry settings (for example, \\SOFTWARE\VERITAS\PRODUCTA\)

`-d, --delete`

Unregisters and removes the product log configuration settings from the main logging configuration file, if there are no originator IDs configured for the product. The corresponding product log configuration file is also deleted.

`-h, --help`

Lists and describes the command-line options available for this command.

`-l, --list`

Displays the configuration settings that are defined.

`-n, --names Name`

Specifies one or more abbreviated or short names for the product. Separate multiple names with a comma.

`-o, --orgid OrgID`

Creates or modifies log configuration settings for the specified originator ID. This option is required. The Originator ID can be supplied as a valid originator ID (a number); it can be "Default," or it can be "ALL." If the Originator ID is "Default," then the -s configuration settings are the default settings. If the Originator ID is "ALL," then the -s configuration settings are considered for all the originators of a given product ID.

`-p, --prodid ProductID`

Creates or modifies the log configuration settings for a *productID*.

`-q, --quiet`

Prevents the display of error or informational messages (quiet mode).

`-r, --remove`

Unregisters and removes the specified product from the list of products by using unified logging and remove unified logging configuration settings for this product.

Note: Although the -r option is available, do not use it. All existing log settings are removed and no further logging takes place.

- `-s, --setting keyname=value`
Sets individual configuration settings when used with `-a` (add option). *keyname* is the configuration setting's name and *value* is the value for that setting. You can use multiple `-s keyname=value` arguments on the command line.
- `-s, --setting keyname`
Removes a configuration setting when it is used with the `-r` option. Use only *keyname* with the `-r` option. To remove multiple settings, provide multiple `-s` options. See the KEYNAMES AND VALUES section for particular key names.
- `-v, --version`
Displays the version information for this command.

KEYNAMES AND VALUES

Following are the key names and values that can be specified on the `-s` option. For NetBackup, the `vxlogcfg` command places these key names and values in the `/usr/opensv/netbackup/nblog.conf` file on UNIX and in `install_path\NetBackup\nblog.conf` on Windows. For PBX, these are placed in `/etc/vx/VxICS/icsul.conf` on UNIX and in the registry entry `SOFTWARE\VERITAS\VxICS\logcfg` on Windows.

Key names and the values for UNIX and Windows

LogDirectory

Provides an absolute path to a directory. No default value.

Caution: When you use the LogDirectory keyname to redirect unified logs to an alternate directory, stop and restart the NetBackup services. This action makes redirection take effect.

DebugLevel

Sets the verbosity level for the debug log messages. (Debug logs are intended for Symantec engineers.) Valid values are 0 through 6.

DiagnosticLevel

Sets the verbosity level for the diagnostic log messages. (Diagnostic logs are intended for NetBackup administrators and users.) Valid values are 0 through 6.

DynaReloadInSec

Dynamically reloads debug and diagnostic settings. Integers 0-60 reload after 60 seconds. Integers greater than 60 reload at the specified number of seconds.

`LogToStdout`

Sends all log messages to standard output (by default the terminal) and to the log file. Valid values are true and false (default value).

`LogToStderr`

Sends the application log messages to Stderr (by default the terminal) and to the log file. Valid values are true and false (default value).

`LogToOslog`

Sends the application log messages to the operating system log (`syslog` on UNIX and the Event Log on Windows). Valid values are true and false (default value).

`RolloverMode`

Specifies when log files are rolled over. If you roll over a log file, it closes the current log file and opens a new one. The purpose is to keep log file size low and allow older log files to be deleted or archived. Valid values are `FileSize`, `LocalTime`, `Periodic`, `FileSize | LocalTime`, `FileSize | Periodic` and `None`.

`FileSize` indicates that the rollover occurs when the log reaches the size that the `MaxLogFileSizeKB` sets. `FileSize` is the default value.

`LocalTime` indicates the log file should be rolled over once per day at a specified time by `RolloverAtLocalTime`.

`Periodic` indicates the log file should be rolled over after the number of specified seconds by `RolloverPeriodInSeconds`.

`FileSize | LocalTime` indicates that the log files are logged over when `FileSize` or `LocalTime` is reached, whichever occurs first.

`FileSize | Periodic` indicates that the log files are logged over when `FileSize` or `Periodic` is reached, whichever occurs first.

`None` indicates that log files are not rolled over.

`MaxLogFileSizeKB`

Specifies the maximum size that is allowed for the log file (in kilobytes) before rollover occurs, if the `RolloverMode` is set to `FileSize`. Valid values are 1 through 4294967295.

`RolloverPeriodInSeconds`

Specifies a period of time in seconds after which the log file is rolled over, if the `RolloverMode` is set to `Periodic`. Valid values are 1 through 2147483648.

`RolloverAtLocalTime`

Specifies the time of day at which the log file is rolled over, if the `RolloverMode` is set to `LocalTime`. Valid values are 00:00 through 23:59.

`NumberOfLogFiles`

Specifies the maximum number of files to retain in the log directory for each unified logging originator. Valid values are 1 through 4294967295.

The `vxlogmgr --auto` command uses `NumberOfLogFiles` to determine how many log files to delete or move, that starts with the oldest files. For example, a log directory contains seven files that a particular originator created. `NumberOfLogFiles` is set to 5. The `vxlogmgr --auto --del` command deletes the two oldest files that the originator created.

LogRecycle

Valid values are true, false. The default value is false. If true, the number of log files does not exceed the `NumberOfLogFiles`.

OIDNames

Specifies one or more alternate names for the unified logging originator that the `-o` option specifies. These names can be used in place of Originator IDs when you perform searches by using the `vxlogview` command. Each name can be up to 80 characters in length. Multiple names can be specified, separated by a space.

L10nLib

Specifies the absolute path and filename of the external localization library. This option is for Symantec internal use only. Use of this option can disable unified logging.

L10nResource

Specifies the name of a localization resource that is associated with a unified logging product or originator. This option is for Veritas internal use only. Use of this option can disable unified logging.

L10nResourceDir

This setting specifies the name of a localization resource directory that is associated with a unified logging product or originator. This option is for Veritas internal use only. Use of this option can disable unified logging.

NtEventLogCategory

Specifies the category number that are associated with log messages that are directed to the Windows Event Log if `LogToOslog` is enabled. In most cases, there should be no need to use this option.

LogFileSDDL

Specifies the Windows Security Descriptor Definition Language (SDDL) string. This string sets the Access Control List (ACL) for the log files that the originator created, which the `-o` option specified. In most cases, there should be no need to use this option.

NtEventLogSourceName

Specifies the Windows Event log that log messages are directed to if the `LogToOslog` option is enabled on Windows. This option is for internal use only. Use of this option can disable unified logging.

EXAMPLES

Example 1

The following sets the LogDirectory for NetBackup and originator ID 111 on UNIX:

```
vxlogcfg -a --prodid 51216 -orgid 111 -s  
LogDirectory=/usr/opensv/logs
```

Example 2

The following sets the DebugLevel and DiagnosticLevel for all unified logging originators in NetBackup:

```
vxlogcfg -a --prodid 51216 -orgid ALL -s DebugLevel=3 -s  
DiagnosticLevel=3
```

Example 3

The following sets the default RolloverMode for product ID 1:

```
vxlogcfg -a --prodid 1 -orgid Default -s RolloverMode=FileSize
```

Example 4

The following displays configuration settings for originator 2 for product ID 1.

```
vxlogcfg -l --prodid 1 --orgid 2
```

Example 5

The following lists all the originators that are configured for product ID 1.

```
vxlogcfg -l --prodid 1
```

Example 6

The following lists all configured products.

```
vxlogcfg -l
```

FILES

```
/usr/opensv/netbackup/nblog.conf  
/etc/vx/VxICS/icsul.conf
```

SEE ALSO

```
vxlogview, vxlogmgr
```

vxlogmgr

NAME

`vxlogmgr` - manages the log files generated by the products that support Unified Logging

SYNOPSIS

```
install_path\NetBackup\bin\vxlogmgr { -d | -c | -m | -F } [-a] -f  
    AbsoluteDir  
install_path\NetBackup\bin\vxlogmgr {-c | -m | -A filename} -f AbsoluteDir  
    [-p ProductID] [-o OriginatorID] [-n Days] [-t Time] [-b Date] [-e  
    Date] [-q] [-z]  
install_path\NetBackup\bin\vxlogmgr {-c | -m | -A filename} -f AbsoluteDir  
    -w QueryString [-q] [-z]  
install_path\NetBackup\bin\vxlogmgr {-d | -F | -s} [-p ProductID] [-o  
    OriginatorID] [-n Days] [-t Time] [-b Date] [-e Date] [-q] [-z]  
install_path\NetBackup\bin\vxlogmgr {-d | -F | -s} -w QueryString [-q]  
    [-z]  
install_path\NetBackup\bin\vxlogmgr -h  
install_path\NetBackup\bin\vxlogmgr -v
```

DESCRIPTION

The `vxlogmgr` utility manages the log files generated by unified logging-enabled applications. Log file management includes actions such as deleting or moving the log files that are based on log management configuration settings.

Unified logging uses a standardized naming format for log files, as follows:

productID-originatorID-hostID-date-rotation.log

For more information about the unified logging naming format, and the logging originator IDs, refer to the *NetBackup Troubleshooting Guide for UNIX, Windows, and Linux*.

OPTIONS

Specify the log management action to perform.

- `-A, --arch FileName`
Creates an archive named *FileName* for the specified set of conditions. The compressed zip file requires WinZip and wzip on Windows to produce a zip file. On UNIX, a tar utility and GnuZip are required to produce a tar.gz file.
- `-a, --auto`
Retrieves the log files that are based on individual configuration settings for *NumberOfLogFiles*. The actions are taken based on the given action type (such as move, copy, or delete). When the `-a` option is specified, the other options cannot be used.
- `-b, --startdate 'Date'`
Manages the log files created at the specified start date. The *Date* format is set from the current locale at run-time and is locale-specific.
NOTE: Use single quotes in this option.
- `-c, --cp`
Copies log files from the folder that the product that is configured to the specified folder.
- `-d, --del`
Deletes log files from the folder that the product configures.
- `-e, --enddate 'Date'`
Manages the log files created up to the specified date. The *Date* format is set from the current locale at run-time and is locale-specific.
NOTE: Use single quotes for in option.
- `-f, --dir AbsoluteDir`
Specify the absolute name of the directory into which the log files are to be copied. This option is valid only with the `-c` option.
- `-F, --flush`
Deletes all log files for the host originating this command except the most current log file. If the host that runs this command uses a shared directory, all log files for all hosts that use the same directory will be removed. Only the most current file is preserved for the host that originated the flush command.
- `-h, --help`
Lists and describes the command-line options available for this command.
- `-m, --mv`
Moves log files from the folder that the product that is configured to the specified folder.
- `-n --days NumberOfDays`
Manage the log files created in last *NumberOfDays* days for the specified action

- o, --origid *OriginatorID*
Manage the log files identified by a given originator ID (*OriginatorID*).
- p, --prodid *ProductID*
Manage the log files identified by a given product ID (*ProductID*) for the specified action. Instead of an identifier, the user can provide the product name.
- q, --quiet
Do not display any messages; quiet mode.
- s, --vw
View the log files for a given query.
- t, --tail *hh:mm:ss*
Manage the log files for the last *hh:mm:ss* hours.
- v, --version
Display the version information for this command.
- w, --where *QueryString*
Retrieve a subset of logs that is based on a query string or condition (*QueryString*).
- z, --displaytimezone
Display the time zone information along with the log file display.

EXIT STATUS

The following exit values are returned:

- 0 Successful completion.
- 1 An error occurred.

QUERY STRINGS

A query string is a text expression, similar to a database WHERE clause, that is used to retrieve log entries from the unified logging system. The expression is a combination of relational operators, constant integers, constant strings, and names of log fields that evaluate to a single value. Logical operators, such as AND and OR, are used to group expressions.

Supported relation operators include:

- < Less than
- > Greater than
- <= Less than and equal to
- >= Greater than and equal to
- = Equal to

!= Not equal to

Supported logical operators include && (logical AND) and || (logical OR).

Predefined log fields include:

PRODID Product identifier (integer or string)
ORGID Originator identifier (integer or string)
STDATE Locale-specific start date (long integer or string [such as 'mm/dd/yy'])
ENDATE Locale-specific end date (long integer or string [such as 'mm/dd/yy'])
PREVTIME Previous time (string [hh:mm:ss])

EXAMPLES

Example 1

The following automatically moves the older log files that NetBackup created to the folder /tmp/nblogs. The --auto option depends on the configuration setting NumberOfLogFiles.

```
vxlogmgr -m --auto --dir /tmp/nblogs
```

Example 2

The following deletes log files that NetBackup created 15 days back:

```
vxlogmgr -d --prodid NB -n 15
```

Example 3

The following copies the log files that are one hour old to the log directory:

```
vxlogmgr -c --tail 1:00:00 --dir c:\temp\logfiles
```

Example 4

The following copies the log files created from date 01/22/07 by NetBackup:

```
vxlogmgr -c --where "(prodid = NB) && (stddate >= '01/22/07')"  
--dir c:\temp\logfiles
```

Example 5

The following copies the log files created between 10/10/06 and 10/28/06 inclusive by product ID 100:

```
vxlogmgr -c --where "(PRODID == 100) && ((STDATE >= '10/10/06')  
&& (ENDATE <= '10/28/06'))" --dir c:\temp\logfiles
```

SEE ALSO

vxlogview, vxlogcfg

vxlogview

NAME

vxlogview - display logs generated by the unified logging component

SYNOPSIS

```
install_path\NetBackup\bin\vxlogview [options] [-l Locale] [-d  
  DisplayOption[,...]]  
install_path\NetBackup\bin\vxlogview [-w queryString] [-l Locale] [-d  
  DisplayOption[,...]]  
install_path\NetBackup\bin\vxlogview -a [-l Locale] [-d  
  DisplayOption[,...]]  
install_path\NetBackup\bin\vxlogview -v  
install_path\NetBackup\bin\vxlogview -h
```

DESCRIPTION

Use the `vxlogview` utility to view the logs that unified logging generates. Search criteria can be specified with command-line options to view specific logs.

Unified logging uses a standardized naming format for log files, as follows:

productID-originatorID-hostID-date-rotation.log

For more information about the unified logging naming format, and the logging originator ID's, refer to the *NetBackup Troubleshooting Guide for UNIX, Windows, and Linux*.

OPTIONS

Specify the logs you want to view.

-A, --audit

Display audit messages.

-a, --all

Display all log messages from log files that multiple Symantec products generated.

-b, --startdate

Display the messages that logged that start at the given start time. The date format is set from the current locale at run-time and is locale-specific

NOTE: In UNIX, use single quotes to enclose the date/time argument. In Windows, use double-quotes.

- C, --crit
Display application log messages having a severity of critical.
- D, --debug
Display debug log messages.
- d, --display *DisplayOption*
Display specified message fields. If multiple *DisplayOptions* are specified, separated each with a comma. *DisplayOption* may be one or more of the following:
 - D - Display date
 - T - Display time stamp
 - m - Display message type
 - p - Display process ID
 - t - Display thread ID
 - P - Display product ID
 - O - Display originator ID
 - c - Display context token
 - s - Display application log entry severity
 - u - Display application or diagnostic Unique Message ID
 - x - Display actual log message text
 - w - Display who logged the diagnostic or debug message
 - i - Display short name for a product
 - o - Display short name for an originator
 - all - Display all fields of the log recordIf -d is not specified, the following fields are displayed by default.
 - Date
 - Time
 - Who (for diagnostic and debug messages only)
 - Severity (application messages only)
 - UMI (application and diagnostic messages only)
 - message text
- E, --err
Display application log messages having a severity of error.
- e, --enddate
Display messages that are logged up to a given end time. If an end time is not specified, it displays messages from the given start time to the end of

the log. If the date is not specified, it takes the current date as default. The date format is set from the current locale at run-time and is locale-specific

NOTE: In UNIX, use single quotes to enclose the date/time argument. In Windows, use double-quotes.

- F, --info
Display application log messages having a severity of info.
- G, --logdir *dir*
Display logs from a given directory instead of a configured log directory.
- h, --help
List and describe the command line options available for this command.
- I, --diag
Display diagnostic log messages.
 - i --fileid *FileID*
Display messages that a given file ID or shared originator ID logged.
- K, --hostname
Display messages that the specified host name logged.
- L, --app
Display application log messages.
- l, --locale *Locale*
Display messages in the locale that *Locale* provides. The messages appear in the current system locale if this option is not given. If the messages cannot appear in the wanted locale, the messages appear in English.
- M, --emerg
Display application log messages having a severity of emergency.
- N, --level
Display debug and diagnostic log messages for a given level.
- n, --days *NumberOfDays*
Display the messages that were logged for last *NumberOfDays* days.
- o, --orgid *OriginatorID*
Display the messages that the given originator logged, which a given originator ID identified. Instead of an identifier, the user can provide the abbreviated name of the product.
- P, --pid *ProcessID*
Display the messages that were logged by a given process ID.

- `-p, --prodid ProductID`
Display the messages that the product (identified by a given product ID) logged. Instead of an identifier, the user can provide the abbreviated name of product.
- `-R, --resdir dir`
Use resources from a given directory instead of a configured localization resource directory.
- `-r, --res Result`
Display audit messages having the specified *Result*. *Result* should be either 0 or 1.
- `-s, --subject Subject`
Display audit messages having the specified *Subject*.
- `-T, --tid ThreadID`
Display the messages that a given thread ID logged.
- `-t, --tail hh:mm:ss`
Display messages for last *hh:mm:ss* hours.
- `-v, --version`
Display the version information for this command.
- `-W, --warning`
Display application log messages having a severity of warning.
- `-w, --where QueryString`
Specify a WHERE clause to use when you query the log messages such that a subset of messages can be displayed. For more detail on *QueryString*, refer to the "Using Logs and Reports" chapter of the *NetBackup Troubleshooting Guide*.
- `-X, --ctx ContextToken`
Display messages that belong to the given context instance. Context tokens identify context instances. If the context token specified is "all," it displays all of the context names and associated tokens.
- `-y`
Display the hostname with each displayed log message. Use this option if log files are coming from different hosts and you want to display which message came from which host.
- `-z, --timezone`
Display messages with time adjusted as per the given timezone.

EXIT STATUS

The following exit values are returned:

- 0 Successful completion.
- 1 An error occurred.

EXAMPLES

Note: The following examples are valid for UNIX, which uses single quotes to enclose option arguments. In Windows, use double-quotes.

Example 1

This example displays the log messages for all the installed products:

```
vxlogview --all
```

Example 2

This example displays the log messages for NetBackup. It displays only the date, time, message type, and message text:

```
vxlogview --prodid NB --display D,T,m,x
```

Example 3

This example displays the log messages for NetBackup that were logged between the dates 1/18/06 and 1/21/06:

```
vxlogview --where "(prodid = 'NB') && (stddate >= '1/18/06 0:0:0 AM' && enddate <= '1/21/06 10:12:00 AM')"
```

Example 4

This example displays the log messages that were created on or after the date and time 1/03/06, 11:00:00 a.m.:

```
vxlogview --stddate '1/03/06 11:00:00 AM'
```

Example 5

This example displays the log messages that were logged within the last hour:

```
vxlogview --tail 1:00:00
```

Example 6

This example displays the audit log messages that have a result of 0:

```
vxlogview --audit -r 0
```

Example 7

This example displays the context log messages for the "job_context" instance:

```
vxlogview --ctx 'jobid=4'
```

SEE ALSO

```
vxlogcfg, vxlogmgr  
vxlogcfg(1), vxlogmgr(1)
```

Index

A

- ACS library
 - Automated Cartridge System 13
- acsd command 13
- Add Media Server on Clients
 - add_media_server_on_clients 15
- add_media_server_on_clients command 15
- ASA database files 356
- Automated Cartridge System 13

B

- Backup Exec
 - listing files 172
- backupdbtrace command 16
- backuptrace command 18
- Bare Metal Restore (BMR)
 - bmrc 20
 - bmrconfig 23
 - bmrepadm 28
 - bmrprep 31
 - bmrts 34
 - bmrstadm 37
- BMR client program 20
- BMR database 358
- bmrc command 20
- bmrconfig command 23
- bmrepadm command 28
- bmrprep command 31
- bmrts command 34
- bmrstadm command 37
- bparchive command 38
- bpbackup command 42
- bpbackupdb command 48
- bpcatarc command 52
- bpcatlist command 53
- bpcatres command 56
- bpcatrm command 57
- bpcd command 58
- bpchangeprimary command 60
- bpclient command 65
- bpclntcmd 69
- bpclntcmd command 69
- bpcompatd command 71
- bpconfig command 73
- bpdbjobs command 83
- bpdbm command 91
- bpdown 94
- bpduplicate command 96
- bperror command 104
- bpexpdate command 114
- bpgetconfig command 124
- bpgetdebuglog command 126
- bpimagerlist command 127, 131
- bpimmedia command 138
- bpimport command 149
- bpinst command
 - examples 161
 - man page 155
 - recreate a key file 160
- bpkeyfile command
 - man page 163
- bpkeyutil command
 - man page 165
- bplabel command 167
- bplic command 170
- bpmedia command 176
- bpmedialist command 179
- bpminlicense command 190
- bpnbat command 193
- bpnbaz command 200
- bpfficorr command 211
- bpplclients command 213
- bppldelete command 220
- bpplinclude command 221
- bpplinfo command 226
- bppllist command 236
- bpplsched command 238
- bpplschedrep command 249
- bpplpolicynew 256
- bppls 261
- bprecover command 265
- bprestore command 271
- bpschedule command 281

bpschedulerep command 288
 bpsetconfig commnad 293
 bpstsinfo command 295
 bpstuadd command 301
 bpstudel command 310
 bpstulist command 312
 bpsturep command 319
 bptestbpcd command 327
 bpup 330
 bpverify command 332

C

cat_convert utility 340
 change_key_file_pass_phrase option 163
 change_netbackup_pass_phrase option 164
 configuring
 encryption, using bpinst command 155
 create_nbdb command 346
 crypt_option 157
 crypt_strength option 157

D

DES
 keys, generating from bpkeyfile 163
 device allocator 377
 disaster recovery 160
 display option 164
 drive
 reset 522

E

EMM database 412, 414
 Enterprise Media Manager 377
 Enterprise Media Manager (EMM)
 EMM database 411

F

force_install option 156

G

generating DES encryption keys 163

I

importtrace command 351
 Inline Tape Copy option 100

installation
 using bpinst command 155

K

key file 160
 pass phrase 159

L

LEGACY_CRYPT option 157
 Licenses
 managing with bpinlicense command 190
 ltid
 acsd command 13

M

Media Contents Report 181
 Media Count Report 182
 Media List Report 179
 Media Manager daemons
 nbpushdata 411
 Media Summary Report 181

N

nbdb_admin command 354
 nbdb_backup command 356
 nbdb_move command 357
 nbdb_ping command 358
 nbdb_restore command 359
 nbdb_unload command 360
 nbdevconfig command 366
 nbdevquery command 373
 nbemm command 377
 nbemmcmd command 378
 nbexecute command 393
 nbftconfig command 396
 nbhba command 404
 nbjm command 406
 nbnos command 407
 nbpem command 408
 nbpemreq command 410
 nbpushdata
 upgrades
 Volume Database host 411
 nbpushdata command 411
 nrb command 418
 nbssodarray command 419
 nbsu command 426

- nbsvrgrp command 431
- NetBackup Access Management 22, 27
- NetBackup daemons
 - nbpushdata 411
- NetBackup database 358
- NetBackup Encryption 155
 - Legacy Encryption 155
 - Standard Encryption 155
- NetBackup Policy Execution Manager 408
- NetBackup Policy Execution Manager Requisition 410
- NetBackup Resource Broker 418
- NetBackup troubleshooting commands
 - backupdbtrace 16
 - backuptrace 18
- NetBackup Vault 100

P

- pass phrase 159
 - restrictions 164
- passphrase_prompt option 158
- passphrase_stdin option 158
- policy_encrypt option 158
- policy_names option 156, 159

R

- recovery (disaster) 160
- reset drive 522
- restoretrace command 434
- robtest 450

S

- set_ndmp_attr command 436
- stdin option 163

T

- tl4d command 443
- tl8cd command 444
- tl8d command 444
- tlcdc command 447
- tldd command 447
- tlhcd command 450
- tlhd command 450
- tlhtest 450
- tlmd command 453
- tlmtest 453
- tpautoconf command 454

- tpclean command 458
- tpconfig command 461
- tpext command 476
- tpreq command 477
- tpunmount command 480

U

- Unified logging 542
 - vxlogmgr 548
 - vxlogview 552
- update_libraries option 157
- Use 414

V

- verbose option 157, 158
- vlteject 489
- vltinject 493
- vloffsitemedia 495
- vltopmenu 499
- vltrun 500
- vmadd command 505
- vmchange command 508
- vmcheckxxx command 516
- vmdelete command 518
- vmopr cmd command 520
- vmphyinv command 526
- vmppool command 530
- vmquery command 533
- vmrule command 537
- vmupdate command 539
- Volume Database host 412, 414, 416
- vxlogcfg 542
- vxlogcfg command 542
- vxlogmgr command 548
- vxlogview command 552

